

www.swisherinc.com

OWNER'S MANUAL

MODEL NO.

STARTING SERIAL #:
L125-213001

SPREADER#
22000



HOBBY FARM PRO TOW BEHIND SPREADER



IMPORTANT

Read and follow all
Safety Precautions
and Instructions
before operating this
equipment.

**Uncrating
Assembly
Operation
Service and Adjustment
Repair Parts**

SWISHER[®]

7/30/2025

SWISHER ACQUISITION INC.
1602 CORPORATE DRIVE, WARRENSBURG, MISSOURI 64093
PHONE (660) 747-8183 FAX (660) 747-8650

Made In The
USA
of US and Global Parts

LIMITED WARRANTY

The manufacturer's warranty to the original consumer purchaser is: This product is free from defects in materials and workmanship for the period's shown below beginning from the date of purchase by the original consumer purchaser. We will repair or replace, at our discretion, parts found to be defective due to materials or workmanship. This warranty is subject to the following limitations and exclusions:

1) Commercial & Consumer Use

This product has a 1-year Limited Commercial and Consumer warranty from the date of purchase.

2) Limitation

This warranty applies only to products, which have been properly assembled, adjusted, and operated in accordance with the instructions contained within this manual. This warranty does not apply to any product of Swisher that has been subject to alteration, misuse, abuse, improper assembly or installation, shipping damage, or to normal wear of the product.

3) Exclusions

Excluded from this warranty are normal wear, normal adjustments, and normal maintenance.

In the event you have a claim under this warranty, you must return the product to an authorized service dealer. All transportation charges, damage, or loss incurred during transportation of parts submitted for replacement or repair under this warranty shall be borne by the purchaser. Should you have any questions concerning this warranty, please contact us toll-free at 1-800-222-8183. The model number, serial number, date of purchase, and the name of the authorized Swisher dealer from whom you purchased the Spreader will be needed before any warranty claim can be processed.

THIS WARRANTY DOES NOT APPLY TO ANY INCIDENTAL OR CONSEQUENTIAL DAMAGES AND ANY IMPLIED WARRANTIES ARE LIMITED TO THE SAME TIME PERIODS STATED HEREIN FOR ALL EXPRESSED WARRANTIES. Some states do not allow the limitation of consequential damages or limitations on how long an implied warranty may last, so the above limitations or exclusions may not apply to you. This warranty gives you specific legal rights and you may have other rights, which vary from state-to-state. This is a limited warranty as defined by the Magnuson-Moss Act of 1975.

TABLE OF CONTENTS

•	SAFETY PRECAUTIONS	4
•	SPECIFICATIONS	5
•	SAFETY AND OPERATION DECALS	6
•	KNOW YOUR SPREADER	7
•	ASSEMBLY PARTS	8
•	UNCRATING	9
•	ASSEMBLY	10
•	GETTING STARTED	11
•	TOW VEHICLE SET UP	12-13
•	CONTROL OPERATIONS	14
•	CONTROL CALIBRATION	15-16
•	SPREAD PATTERN ADJUSTMENT	17
•	GENERAL OPERATIONS	18-19
	– GENERAL RECOMMENDATIONS	
	– GETTING STARTED	
	– SPREADING RECOMMENDATIONS	
	– STARTING SPINNER DISC	
	– BEFORE YOU START SPREADING	
	– SPREADING IN FIELD	
	– SPREAD ZONE COVERAGE	
•	SPREADER MAINTENANCE	20
	– GENERAL RECOMMENDATIONS	
	– BEFORE EACH SEASON	
	– BEFORE EACH USE	
	– AFTER EACH USE	
•	CLEANING GUIDELINES	21
•	TROUBLESHOOTING	22
•	PARTS DIAGRAMS	23-31
	– FRAME ASSEMBLY	
	– GEARBOX ASSEMBLY	
	– TIRE & AXLE ASSEMBLY	
	– HITCH ASSEMBLY	
	– SPINNER DISC ASSEMBLY	
	– DEBRIS GUARD	
	– OFFSET GATE CONTROL	
	– FLOW GATE CONTROL	
	– CONTROL ASSEMBLY	
	– HOPPER ASSEMBLY	
	– HOPPER MOUNTING ASSEMBLY	
•	CALCULATING MATERIAL FLOW	32
•	SPREADER LOG NOTES	33-34

SAFETY PRECAUTIONS

Thank you for choosing Swisher's Tow-Behind Spreader. Before operating your Spreader, please read, understand and follow all of the safety precautions and other instructions explained in this manual. As with all power equipment Spreaders can be potentially dangerous if improperly used.



This Safety Alert Symbol indicates important messages in this manual. When you see this symbol, carefully read the message that follows and be alert to the possibility of personal injury.

Read this manual completely. This machine can injure hands and legs, and throw objects. Failure to observe the following safety instructions could result in serious injury or death.

- Read the manual. Learn to operate this machine safely.
- Keep all shields and guards in place.
- Understand the speed, steering and stability of this machine. Know the positions and operations of all controls before you operate this machine. Check all of the controls in a safe area before starting to work with this machine.
- Allow only responsible adults who are familiar with these instructions to operate this machine. **Never allow children to operate this machine.**
- Be sure the area is clear of other people before spreading. **Stop the machine** if anyone enters the spreading area. Children are often attracted to the machine and the spreading activity. **Never assume that children will remain where you last saw them.** Keep children under the watchful care of another responsible adult.
- **No riders!**
- Do not put hands or feet near or under rotating parts.
- Do not spread in reverse. **Always look down and behind before and during backing.**
- Disconnect Axle Pin when not spreading material.
- **Watch for traffic** when operating near or crossing roadways.
- Do not operate the Spreader if it has been dropped or damaged in any manner or if the Spreader vibrates excessively. **Excessive vibration is an indication of damage.** Repair Spreader as necessary.
- Use proper handling procedures for the material you are using. Obey all safety precautions advised by the material manufacturer.
- Dress properly. Protect skin and body parts from flying material and dust.
- Do not operate the machine while under the influence of alcohol or drugs.
- Do not operate on slopes greater than **15 degrees**.
- Stop and inspect the equipment if you strike an object. Repair, if necessary, before resuming.
- Volume of material and weight of material vary by the material's density. Always pay attention to the **amount of weight** you are putting into the Hopper. **Do not exceed the 600 lb capacity.** Some materials will reach 600 lbs before the Hopper is full.
- Do not exceed the recommended speed with towing. 5 MPH while spreading/loaded and 15 MPH while transporting an **empty** unit.
- Always remove the axle pin when transporting the spreader. Do not travel long distances with a fully loaded hopper as this will cause the material to compact and can result in poor operation or equipment damage.

SPECIFICATIONS

	Description
Gearbox	3.3:1 gears, Aluminum Cast Housing
Gearbox Oil	SAE 90W/80W90 ; 12 oz. (.35 lt)
Drive System	Ground Driven, One Drive Wheel
Overall Dimesions	44" L x 44" W x 54" T
Unit Dry Weight	200Lbs. (90.7 Kg)
Spread Orientations	Left, Full & Right
Spreading Width	Dependant on Material; up to 30ft
Hopper Capacity	600 lbs
Towing Speed	15 MPH MAX
Spreading Speed	5 MPH (Flat Ground) 4 MPH Max (Rough Ground)
Tire PSI	20 PSI Recommended (Min. 15 PSI - Max 35 PSI)

Quick Reference - Maintenance Parts

Description	Part Number
Washer - Plastic, 1/2" ID	21967
Wheel/Tire - 15/650-8	21934
Pin - Drive Axle	21986
Fin - Spinner Disc	21939GV
Agitator Head	21989GV
Agitator Bolt & Nut	NB218 & 22609
Cotter Pin - Agitator Shaft	19036
Agitator Spring	12364

Note:

- For other part numbers, refer to the Parts Diagrams on pages 23-31.



SAFETY AND OPERATION DECALS

Replace decal immediately if damaged.

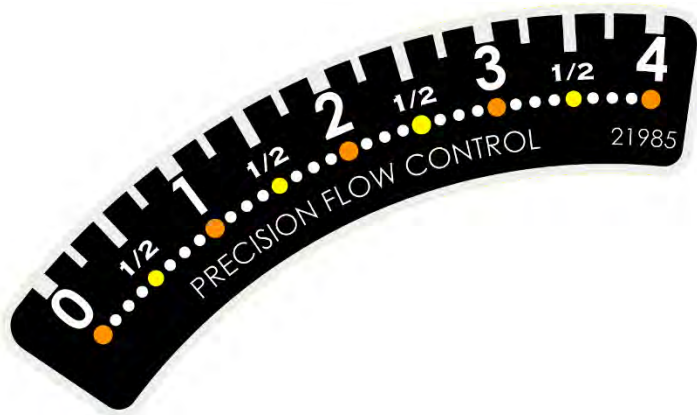

21985-GATE SETTING DECAL



OD33-5MPH DECAL



OD55 DANGER KEEP AWAY



21916- LEVEL DECAL



21914- AXLE PIN DECAL



21915- CAPACITY DECAL



21969- CONTROL OPERATION DECAL



21977- FLYING DEBRIS DECAL

KNOW YOUR SPREADER



It is important to know the features of the Spreader. Please review the entire manual for detailed operational and safety information.

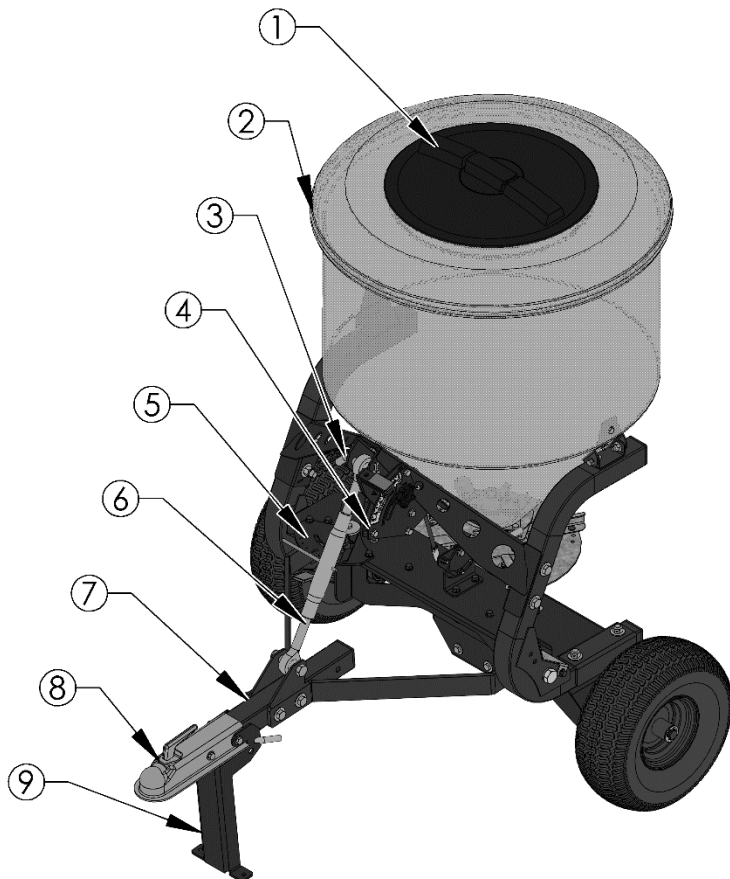

- ① Vented Lid
- ② Poly Hopper
- ③ Removable Link Pin
- ④ Flow Controls
- ⑤ Offset Controls
- ⑥ Leveling Link
- ⑦ Adjustable Hitch Bar
- ⑧ 2" Ball Coupler
- ⑨ Hitch Stand

- ⑩ Drive Wheel
- ⑪ Free Wheel
- ⑫ Spreader Disc & Adjustable Fins
- ⑬ Removable Axle Pin
- ⑭ Gearbox
- ⑮ Adjustable Linkages

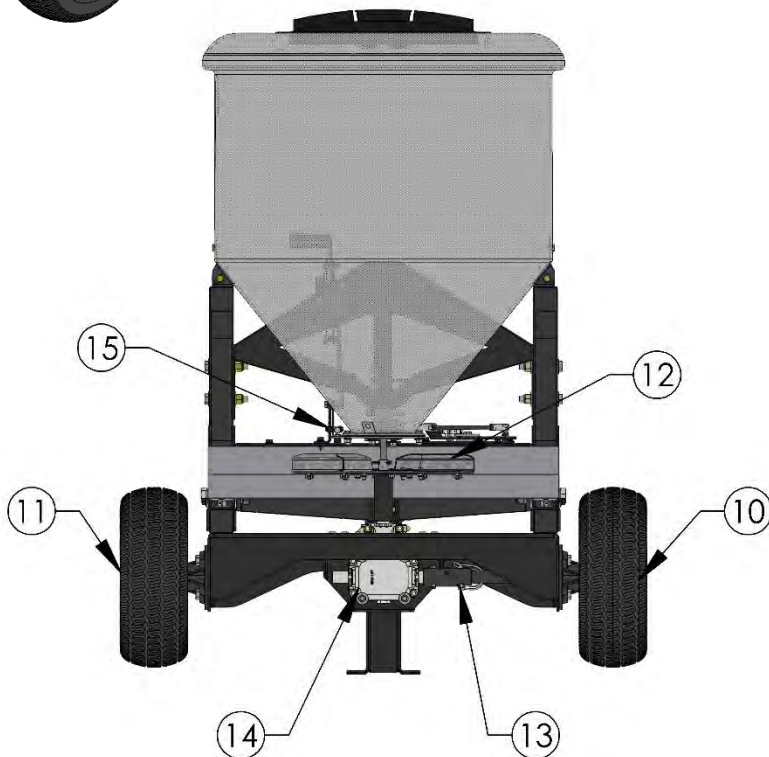

ASSEMBLY PARTS



Before assembling the Spreader make sure that all assembly parts are present.

Item #	Description	Part #	Qty
1	Hitch Bar Pre-Assembly	-	1
2	Plate - Top Link Hitch Bracket	21951*	2
3	Top Link	21103	1
4	Pin - Bent w/Hair Pin, 5/8 X 3	NB702	1
5	Pin - Bent w/Hair Pin, 1/2 X 3	NB606	1
6	Bolt - 1/2-13 X 4"	NB132	2
7	Bolt - 5/8-11 X 3"	NB699	1
8	Washer - USS Flat, 1/2	NB555	4
9	Nut - 5/8-11 Nylon-Insert Lock	21138	1
10	Nut - 1/2-13 Nylon-Insert Lock	NB281	2

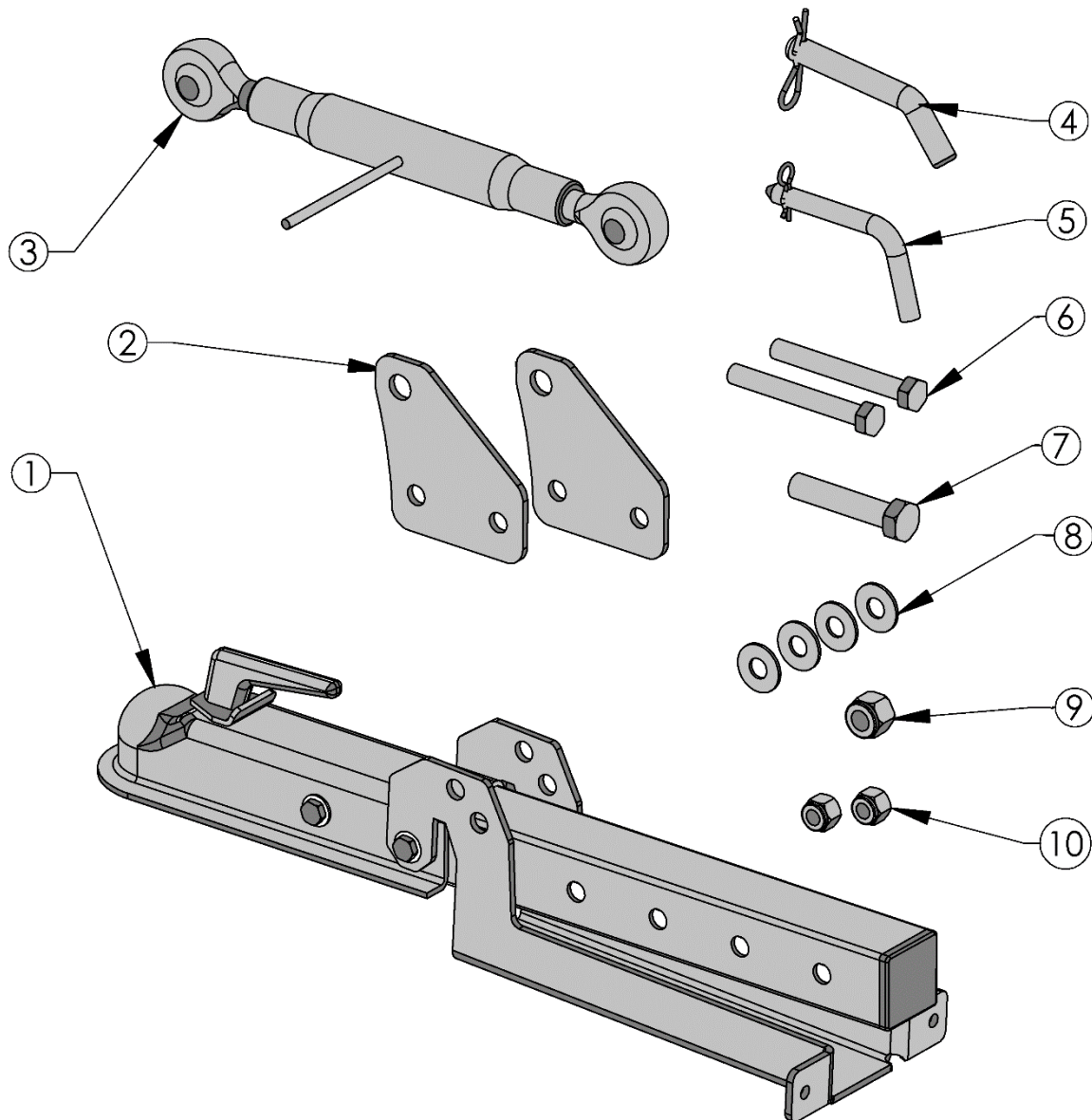

UNCRATING

Tools Required:

Wrench/Socket

Qty.	Size
(2)	3/4"



Pry Bar



Hammer



Safety Glasses



Gloves

GENERAL RECOMMENDATIONS

- Use at least two people to uncrate & assemble the unit. The Spreader and its components are heavy.
- Refer to **page 36** for recommended hardware torque values.

UNCRATING

- Using a hammer and pry bar, separate the crate side at the front of the Spreader. **Use caution to not damage the equipment inside the crate.**
- Always wear gloves and safety glasses when disassembling the crate.



**Use care
when
uncrating.**

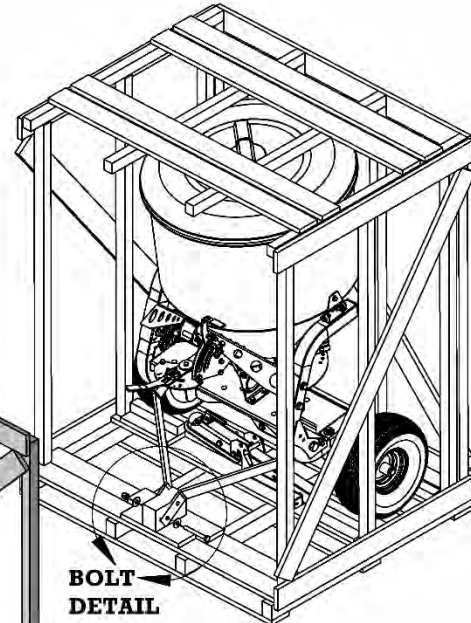

FIGURE 9.1

UNCRATING DIRECTIONS

1. Using the required tools, remove the front panel of the crate. The front panel is the side of the crate that the hitch arms are facing as shown in **FIGURE 9.1**. This is the only side that needs to be removed for uncrating the unit. The entire crate can be disassembled if you choose, but it is not required for assembly.
2. After the front crate panel has been removed, locate the hitch bars that are bolted to the wooden block. This bolt will be removed. See **FIGURE 9.2**
3. Have a second person hold the spreader upright when removing this bolt. **Once this bolt is removed the Spreader can fall forward. Use Caution!**
4. Slowly Lower the Unit forward until it is resting on the hitch arms.
5. Follow the Assembly instructions on page 10.
6. After the unit is assembled, remove the zip ties holding it to the crate base.
7. Remove the wheel chocks holding the front of the spreader tires in place.
8. The spreader can now be rolled out of the crate.
9. Check that all hardware is secure before using.

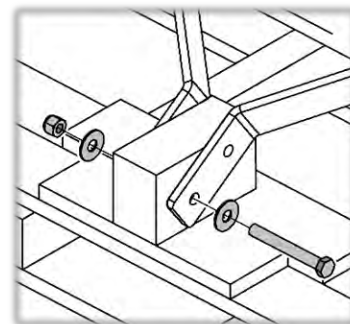

FIGURE 9.2

ASSEMBLY DIRECTIONS



Item numbers shown are referencing the assembly parts list on **PAGE 8**.

Tools Required:

Wrench/Socket



Qty.	Size
(2)	3/4"
(2)	15/16"

ASSEMBLY DIRECTIONS

1. Check that all parts are present before beginning assembly. See **page 8**
2. Uncrate the Spreader using the directions on **page 9**.
3. Next, locate the Hitch Coupler Bar pre-assembly (1). Notice there are multiple empty holes. This allows for you to locate the spreader distance to the tow vehicle, so the control handle is reachable.

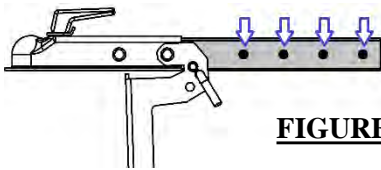

FIGURE 10.1

4. After deciding which mounting holes best suits your tow vehicle, assemble the hitch components.
5. Place the Hitch Bar (1) in between the Top Link Brackets (2) and Hitch arms as Shown in **FIGURE 10.2**. The Plates (2) go in between the hitch arms and the Hitch Tube. See **FIGURE 10.3** for an assembled hitch image if needed.

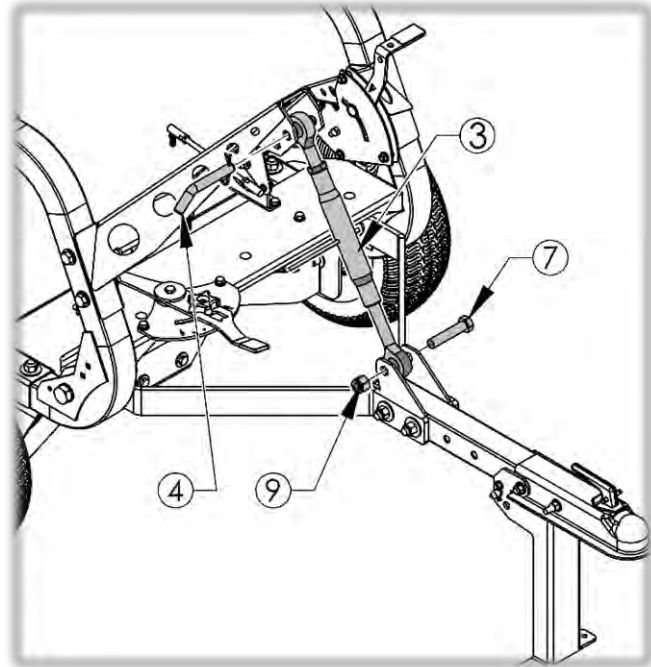

FIGURE 10.2

ASSEMBLY DIRECTIONS CONTINUED

6. Next using one 5/8"-11 Bolt (7) & one 5/8"-11 Nylon Lock Nut (9), assemble the bottom section of the top link (3) between the top link Brackets previously installed per **Figure 10.2**. Tighten until at least one thread protrudes from the backside of the Nylon Nut.
7. Lastly connect the Top Link to the top of the Spreader Frame using the Removable 1/2" Pin (4) and hair pin.
8. After fully Assembled, ensure all hardware has been tightened.
9. The Spreader is now fully assembled. Follow the guidelines in this manual to ensure the control linkages are calibrated and all other hardware is secure.

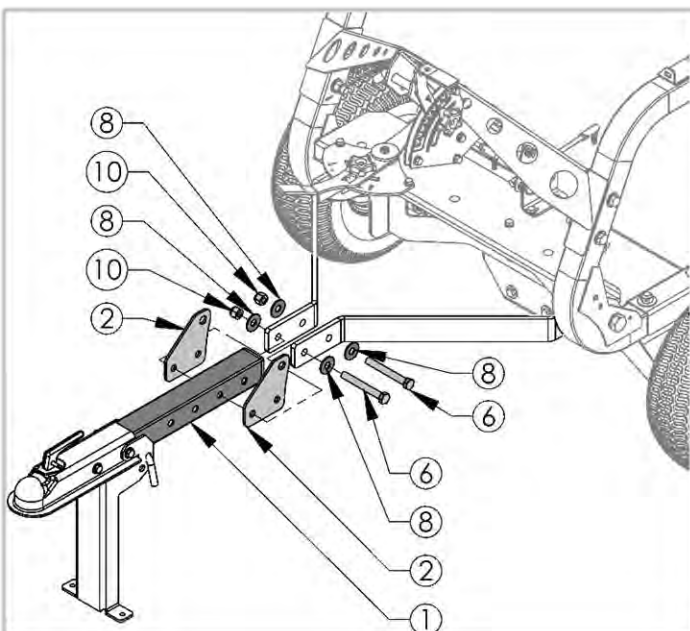

FIGURE 10.3

GETTING STARTED



The operation of any spreader can produce foreign objects that can be thrown into the eyes, resulting in severe eye damage. Always wear certified safety glasses or wide-vision safety goggles over spectacles when standing near a spinning spreader disc.



CAUTION! This Spreader is not intended for roadway use. It is not advised to transport this spreader on the roadway without proper lights, signage and safety features. Always refer to applicable laws in your area for proper roadway use. Do not exceed 15 MPH when transporting with an empty hopper or 5 MPH with a loaded Hopper.



CAUTION! Tragic accidents can occur if the operator is not alert to the presence of children. Children are often attracted to the machine. **Never assume that children will remain where you last saw them.**



Always inspect the Spreader before each use. Ensure all hardware is tight and all moving parts are in proper working order. Machine damage and/or injury can occur if Spreader operates with defective parts.



The Spreader has high speed components and throws debris a long distance. Always make sure no one is within 100 feet of the spreader when in use. Stop use if someone approaches spreader.

BASIC SPREADER CONCEPTS

Your tow behind spreader uses the centrifugal force from a spinning disc to “spread” material. The spinner disc is connected to a gearbox that is connected to an axle/tire. The tire will turn when the unit is pulled by the tow vehicle, and this will cause the disc to spin. The speed the disc spins is determined by the speed the unit is being pulled. The material will throw farther and provide a thinner layer of coverage as the tow speed is increased. Inversely, the spread coverage will become thicker and shorter as the tow speed is decreased.

INTENDED USE

The Tow Spreader is designed to spread material at a designated flow rate. It is recommended to calculate your flow rate before use for the most accurate application. Your Tow Spreader should be towed behind an ATV/UTV, golf cart, lawn mower, or tractor or other similar vehicle. It is not recommended for operating speeds exceeding **5 MPH**.

MANUAL TERMINOLOGY

- Whenever “Left” or “Right” is used in this manual it refers to the left- or right-hand side of the unit as it is in forward motion being viewed from behind.
- Refer to the “KNOW YOUR SPREADER” section for a brief overview of the spreader components.
- “Material” refers to the product that is being spread (e.g. Grass seed, sand, salt etc...)
- **FIGURE** references used throughout reflect the page number as the first number (e.g. **FIGURE 20.1** is on page 20, **FIGURE 15.2** is on page 15, etc...).

SPREADER & TOW VEHICLE SET-UP

GENERAL RECOMMENDATIONS

- It is not recommended to tow behind a car or truck.
- The Tow Hitch Bar is adjustable so the Control Handle can be reached from the tow vehicle.
- Ensure the tow vehicle is rated to tow the weight of the loaded Spreader.
- If the Control Handle is unreachable from the tow vehicle, refer to **page 10** for instruction on adjusting the Hitch Bar length.

TOW VEHICLE REQUIREMENTS

- The tow vehicle must be equipped with a 2" ball.
- The top of the 2" ball should be no less than 11" and no more than 20" off the ground. Anything outside of this range will require additional equipment to raise or lower the ball height as needed so that the Hopper can be leveled.

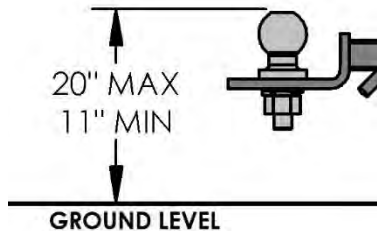

FIGURE 12.1

IMPORTANT SAFETY INFORMATION

- ALWAYS Chock the Wheels of the Spreader so it cannot roll when not attached to tow vehicle.
- Always pin the Hitch latch closed to prevent the hitch from disconnecting unexpectedly.
- Never Fill Hopper without the spreader being connected to a tow vehicle.

CONNECTING SPREADER

- Connect the Spreader to the tow vehicle while the Spreader is empty.
- Remove the ½" Pin from the hitch stand. Lift the Spreader tongue and swing the Stand under the hitch bar so it is out of the way.
- Set the ball coupler on the 2" ball and push the coupler lock handle down. This locks the coupler to the ball. Insert the safety pin (NB518) into latch handle to keep the lock from accidentally unlatching during use.
- Swing the Stand up against the bottom of the hitch bar. Re-insert the previously removed ½" pin into the lower hole to retain the stand in the up position.

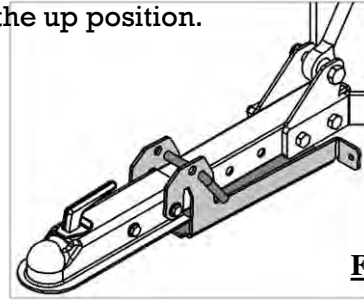

FIGURE 12.2

- Level the Spreader. See **page 13** for leveling instructions.

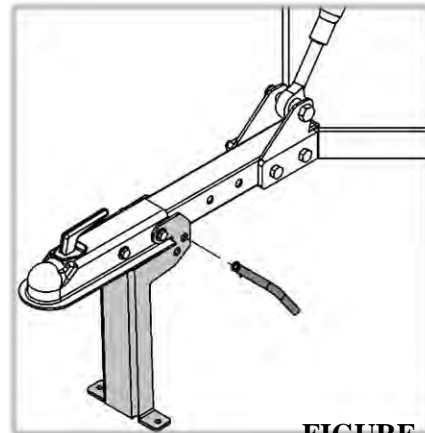

FIGURE 12.3



CAUTION: NEVER ATTEMPT TO MANUALLY MOVE, CONNECT OR DISCONNECT A FULLY LOADED SPREADER.

SPREADER & TOW VEHICLE SET-UP



WARNING: ALWAYS LEVEL THE HOPPER WITH AN **EMPTY HOPPER!** A FULLY LOADED SPREADER CAN CAUSE THE UNIT TO BE UNSTABLE UNTIL IT IS PROPERLY LEVELED.



WARNING: ALWAYS SET THE PARKING BRAKE ON THE TOW VEHICLE BEFORE WORKING WITH THE EQUIPMENT TO PREVENT ACCIDENTAL MOVEMENT.

Tools Required:



Wrench
Qty. Size
(1) 3/4"



DO NOT OVEREXTEND THE TOP LINK. The maximum span of the top link is 18". If the top link is extended beyond this, it may come apart.



LEVELING THE HOPPER

- After the Spreader is securely attached to the tow vehicle, it is necessary to level the Spreader to the best of your ability.
- To level the Spreader, make sure the tow vehicle and Spreader are on a relatively level flat surface.
- Locate the Leveling top link in the front of the unit. **See FIGURE 13.1**
- Using a wrench loosen the jam nut located on the top link threads. Thread the jam nut up the threads so it is out of the way.
- Once the jam nut is moved, determine if you need to make the Hopper lean towards the tow vehicle or away from the tow vehicle to bring it to level.

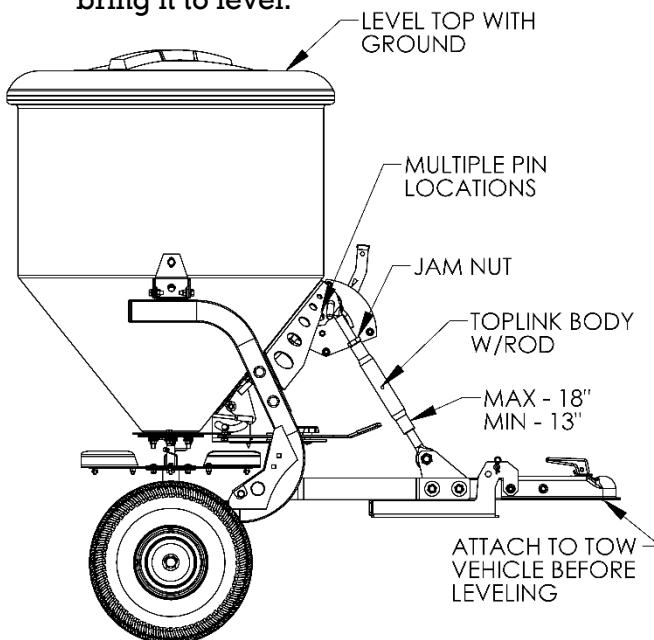

FIGURE 13.1

LEVELING THE HOPPER CONTINUED

- If you need to make the Hopper come towards the Tow Vehicle, then you will shorten the top link.
- If you need to make the Hopper go away from the Tow Vehicle, then you will lengthen the top link.
- To change the top link length, find the rod in the center of the top link body and use it to rotate the body. Rotating the top link body in one direction will lengthen it and rotating in the opposite direction will shorten it.

TRANSPORTING SPREADER

- Never transport long distances with a loaded Hopper.
- When transporting the Spreader remove the Axle Pin and place it in the Pin Storage Hole indicated by the "AXLE PIN" Decal. Only have pin placed in the axle when actively Spreading. **See FIGURE 13.2**

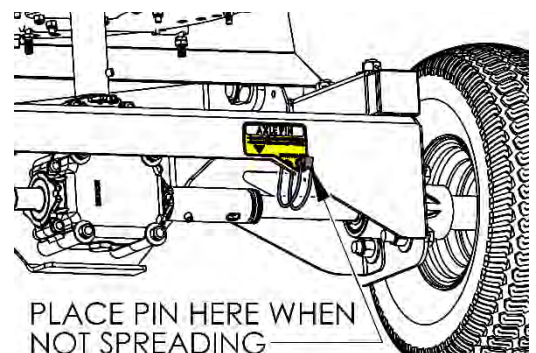

FIGURE 13.2

CONTROL OPERATIONS

FLOW CONTROL HANDLE

- Locate the Flow Control Handle on the operator side of the Spreader as shown on **page 7**.
- The Indicator Dial has marked intervals to represent the amount of material that is dropped while spreading. See **page 30** for information on how to calculate the flow rates for your desired medium.

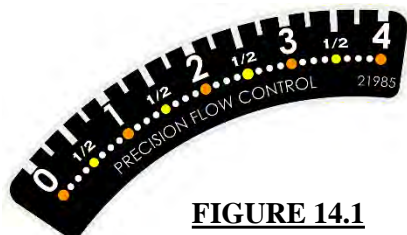

FIGURE 14.1

- The Control Assembly has two indicator arrows for the operator to select the desired flow rate. The red arrow indicates a pre-set open setting. The arrow on the Handle indicates the current opener location.

FLOW CONTROL HANDLE OPERATION

- The Red Arrow indicates a pre-set value. This position is selected by loosening the Black Knob and moving the Indicator to the desired setting.
- Once the Indicator Arrow is pointing to the desired setting, tighten the Black Adjustment Knob to lock handle stop in place. The Control Handle will not be able to move past the pre-set value.

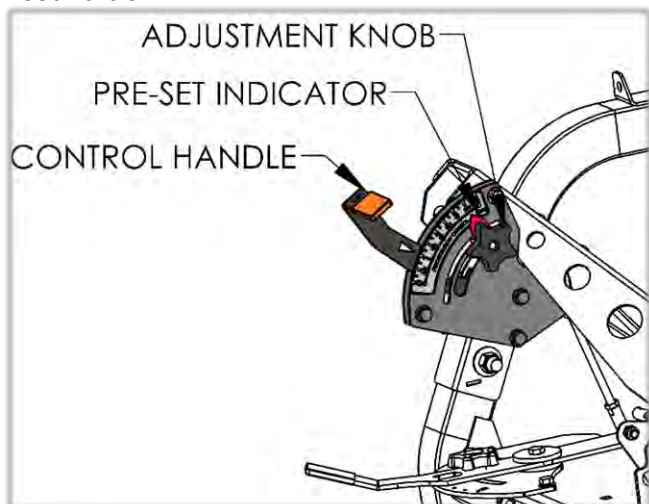

FIGURE 14.2

OFFSET ADJUSTMENT HANDLE

- Locate the Offset Control Handle located on the Frame cross member as shown on **page 7**.
- The Offset Control Handle has an indicator plate that reflects the direction the material will be spread.
- When the Handle is set to the dot below the “R” material will Spread a 90° Fan the “Right” side as the unit is in operation.
- When the Handle is set to the dot below the “C” material will Spread a Full 180° Fan pattern.
- When the Handle is set to the dot below the “L” material will Spread a 90° Fan the “Left” side as the unit is in operation.

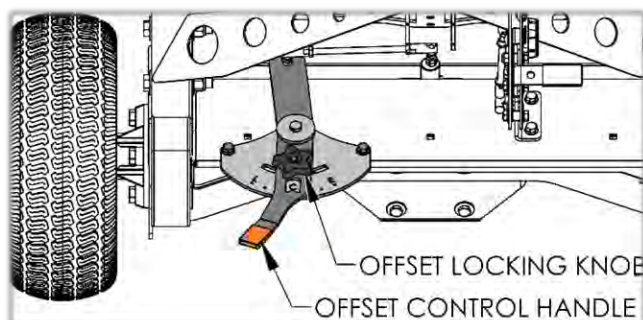

FIGURE 14.3

OFFSET ADJUSTMENT HANDLE OPERATION

- Slightly loosen the Offset Locking Knob by turning Counterclockwise. The knob only need to be loosened enough to allow the Offset Control Handle to move.
- Once the Knob is loosened, move the handle to the desired spread direction as described above. Retighten the Knob.
- The point located inside the handle viewing cutout indicates the position of the Offset Plate.

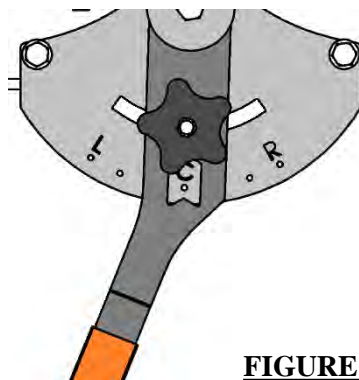

FIGURE 14.4

CONTROL CALIBRATION

GENERAL RECOMMENDATIONS

- Calibrate the controls with an empty hopper.
- It is easier to have two people when calibrating the control linkages. One person to watch the slide plates and the other person operating the controls and making the necessary adjustments.
- It is recommended to calibrate the controls often to ensure proper functionality of the slide plates.

Tools Required:



Wrench	
Qty.	Size
(2)	1/2"
(1)	7/16"



Pliers
(Optional)

OFFSET ADJUSTMENT HANDLE

- 1) To Calibrate the Offset Control Handle, place the handle to "C" Center position and lock in place as shown in **FIGURE 15.1**
- 2) Set the Flow Control Handle to Setting "4" (Fully Opened).

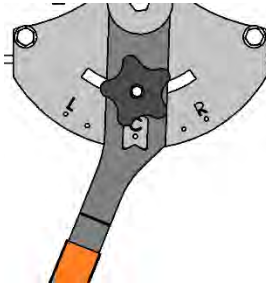

FIGURE 15.1

- 3) When standing at the rear of the Spreader looking into the Hopper, see which hole is not fully Open. If both holes are not fully opened then follow the "**Flow Control Calibration**" Steps on **page 16**. If only one hole is partially covered, take note as to whether it is the right hole or the left hole. If both holes are fully open, no adjustment is needed.

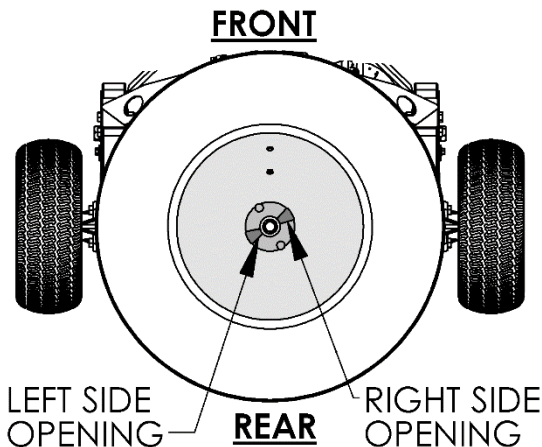

FIGURE 15.2

Opening Holes

- 4) Go back to the Offset Control Handle and locate the Linkage rod as shown in **FIGURE 15.3**.
- 5) Using a 7/16" & 1/2" open end wrench, loosen the jam nuts at both ends of the rod. One nut is left-hand thread and one is right-hand thread.
- 6) Once the jam nuts are loose and moved away from the ball joint, turn the rod to lengthen or shorten the linkage. If the left hole was covered then shorten the linkage. If the right hole was covered then lengthen the linkage. Adjust rod as necessary until both holes are fully opened.
- 7) Once both holes are fully opened re-tighten the jam nuts.

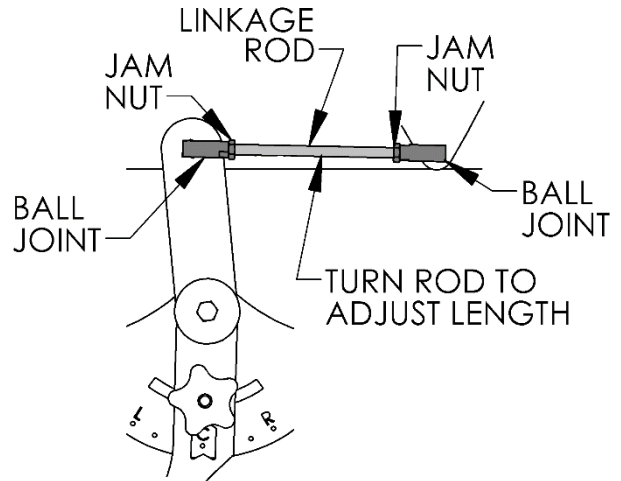

FIGURE 15.3

Offset Control Handle Linkage

CONTROL CALIBRATION

FLOW CONTROL HANDLE CALIBRATION

- 1) To calibrate the Flow Control Handle, place the handle to the Zero (0) Setting. Loosen the Flow Control Handle Adjustment Knob and position it at the Zero (0) Location also. This will lock the Control in the fully closed position.

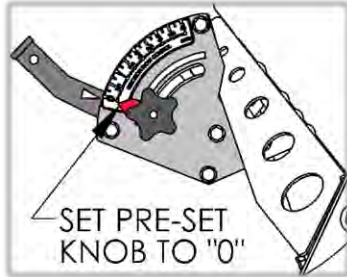

FIGURE 16.1

- 2) Next, look inside the Hopper at the slide plates. The opening holes should be fully closed. If they are fully closed, skip to step 10. If not continue on to step 3.
- 3) With the handle still locked in the closed position, locate the Control Handle linkage rod connection Pivot Plate.
- 4) The Pivot Plate should be in the up position and the Ball Joint Nut should be nearly bottomed out in the slot as shown in **FIGURE 16.2**.

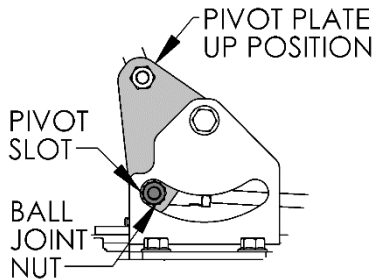

FIGURE 16.2

- 5) If the Nut is not bottomed out in the slot then find the Control Handle Linkage Rod.
- 6) Using a 7/16" wrench and 1/2" wrench, loosen the jam nuts on the rod. One of the nuts is right hand threaded and the other is left hand threaded.

FLOW CONTROL HANDLE CALIBRATION

- 7) After the nuts are loosened turn the linkage rod to lengthen or shorten the rod as needed to bring the plate into the correct position as shown in **FIGURE 16.3**. Re-tighten the jam nuts on the linkage rod.
- 8) Look inside the Hopper to see if this adjustment has fully closed the Holes at the bottom. If so, skip to step 10. If not continue to step 9.
- 9) Locate the linkage rod connecting the pivot bracket to the slide plate on the Hopper. Follow steps 6 & 7 on this linkage rod to moved the Slide plate into the fully closed position.
- 10) After the rods have been adjusted, verify they are correct by loosening the Flow Control Adjustment Knob and moving the Handle to Setting (4) fully open. Look inside the Hopper and verify the Holes are Fully Opened.

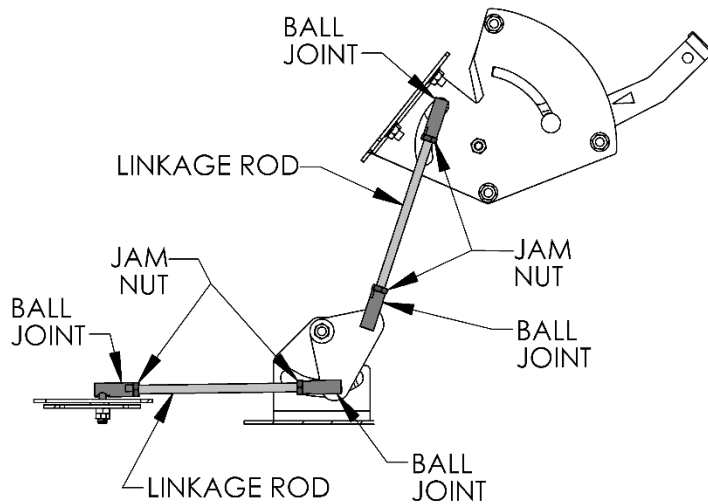

FIGURE 16.3

SPREAD PATTERN ADJUSTMENT

SPREAD PATTERN

- By positioning the Offset Adjustment Handle detailed on **page 14**, you can set the spread pattern. See Spread Patterns in **FIGURE 17.3**
- **Note: Due to the nature of using rotational force to “throw” the material it is impossible to completely eliminate material from throwing in a certain direction. The use of the Offset Handle will drastically reduce the amount of material dispersed to one side.**
- It's recommended to do a couple test passes with the desired material to see how it will react when being dispersed. If needed you can fine tune the spread pattern by gradually adjusting the Offset Control Handle or using the adjustable fin on the spinner disc.

FINE TUNING SPREAD PATTERN

- If you notice the spread pattern becomes heavier or uneven to one side utilize the Offset Handle to limit material flow to the heavy side.
- For example, if the material is flowing heavier to the right side then move the Offset Adjustment Handle slightly towards the “L” Left. This will reduce material flow to right side of the unit. The farther the handle is moved away from “C” the more the flow is restricted.

- The adjustment Fins will let you fine tune the spread pattern. Move the fins in the direction that you want more material to be applied. (e.g. If the material is spreading too heavy to the left then move the Fins to the right for the spread to become heavy on the right. See **FIGURE 17.1**.)
- **Note: When you move fins to the left this will lessen the distance the material is thrown. When the fins are set towards the Right this will increase the distance the material is thrown.**

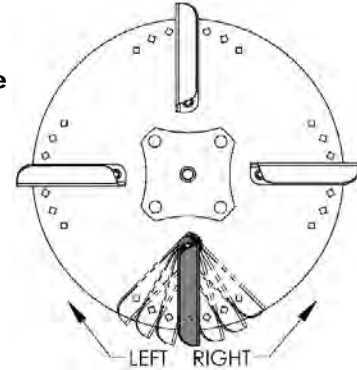

FIGURE 17.1

- To adjust the fins, remove the wing nut and carriage bolt that connected the Fin to the Spinner Disc. The Fin should now be free to pivot around the rear bolt.

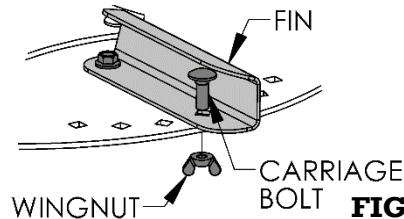

FIGURE 17.2

- Adjust the Fin in the desired direction and replace the carriage bolt and wingnut.

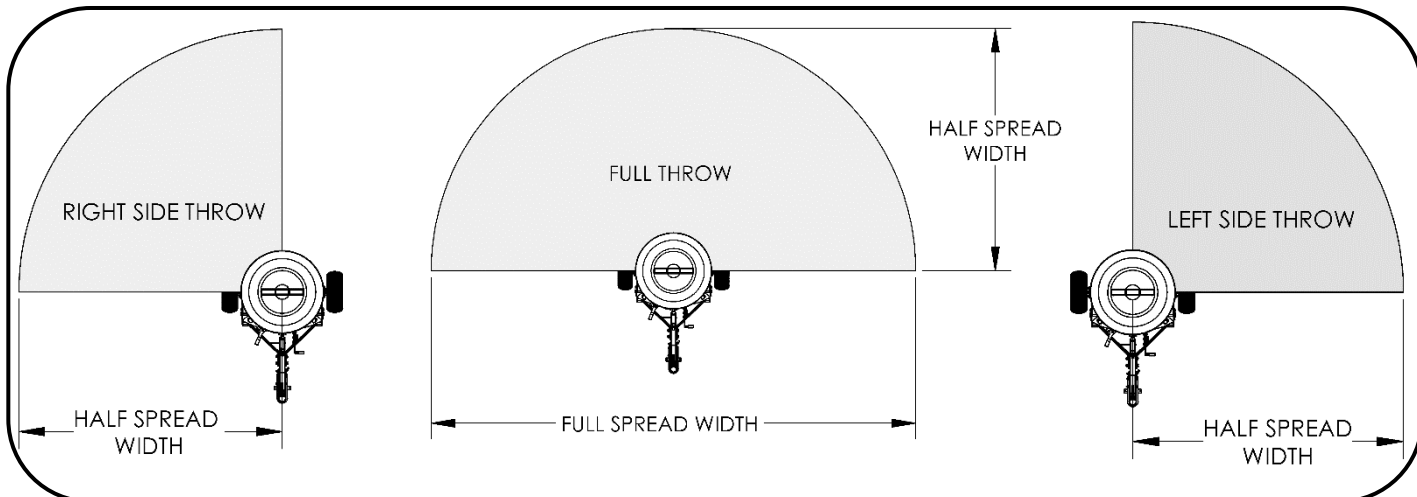

FIGURE 17.3

Spread Patterns

GENERAL OPERATIONS



Always inspect the Spreader before each use. Ensure all hardware is tight and all moving parts are in proper working order. Machine damage and/or injury can occur if Spreader operates with defective parts.

GENERAL RECOMMENDATIONS

- ⚠ Learn and refer to all safety warning in this manual before operating the Spreader.
- If Spreader is being on or near a roadway always follow local laws and regulations for road transporting in your area. **The Spreader is not designed for high-speed roadway use! Do not exceed 15 MPH when transporting an empty unit with the axle pin removed. Do not exceed 5 MPH with the axle pin in place and/or a loader Hopper.**

GETTING STARTED

- Is it important to learn all the operations discussed in this manual before starting.
- Decide whether or not the Agitator Head is to be used before filling the Hopper. The Agitator can cause damage to some coated and/or delicate seeds. **Calculate the flow rate of the material to be spread for the most accurate results.**
- Ensure the flow gate is closed prior to filling.



FILLING THE HOPPER

- ⚠ **Make sure the Spreader is securely connected to the Tow-Vehicle.**
- ⚠ **Always fill the hopper at the site where the material is to be spread. Traveling with a full Hopper will cause the material to compact and can result in poor spreading.**
- The recommended method of filling the Spreader is to place the **unopened** bag of material on the top ledge of the Hopper. Place the end of the bag to be opened into the opening of the Hopper. Open the bag and let the material fall into the hopper by lifting the opposite end of the bag. Repeat this step until the desired amount of material is in the Hopper and then replace the Hopper Lid.

SPREADING RECOMMENDATIONS

- When spreading the first pass, take note of the spread width and distribution pattern.
- Pay close attention to your speed, as this will directly impact the spread width and material coverage area. The faster you go, the wider and thinner the coverage will become. The slower you go, the thicker and narrower the coverage area will become. It is important to maintain a consistent speed for even coverage.
- If the pattern seems to be uneven or applies material heavier in one direction, then follow the instructions for FINE TUNING THE SPREAD PATTERN on page 17.

STARTING SPINNER DISC

- **Ensure the axle locking pin is in place. SEE FIGURE 18.1** Once the Drive axle is attached to the Gearbox, the Spinner Disc will spin upon forward or backwards movement of the spreader.
- Ensure the Hopper is level.
- Set the Pre-set Knob to the desired Open setting on the Flow Control Handle.
- Set the desired material spread offset (Left, Right or Center).
- You are ready to spread!
- Follow the pattern in **FIGURE 19.1** for best results.

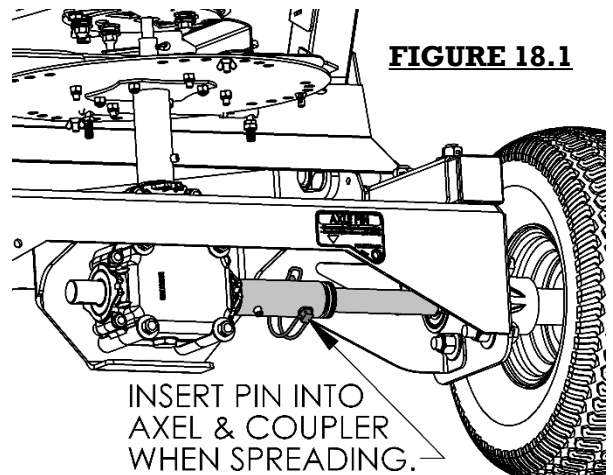

GENERAL OPERATIONS

BEFORE YOU START

- ***It is strongly recommended to calculate the spread pattern and flow rates of the material you will be spreading. If you do not do this, the spreader may not produce desired results. See page 30-32 for flow rate calculation procedures.***

SPREADING IN FIELD

- There are many effective ways to use the spreader. The following guideline is a suggested way to ensure even coverage.
- For best results, it is recommended to set the flow rate at half of the desired coverage and cover the area twice. The second coverage route should be perpendicular to the first coverage route. This is the best method to achieve even coverage with lower chances of thin or missed spots.

SPREAD ZONE COVERAGE

See **FIGURE 19.1**

1. Position the Spreader in the corner of the area to be covered as indicated by the "START POINT" at half the spread width from both edges of the spread area.
2. Open gates to the desired flow rate setting and begin moving forward at the required speed along route "A". Route "A" will continue around the perimeter at a Half Spread Width distance from the edge of area.
3. Once you are a distance of $SW/2$ from the "Start Point", turn to continue along route "B". Route "B" and route "A" should be a Spread Width apart. Make sure to not leave a gap between route "A" and "B".
4. When you reach route "A" close the gate and turn the unit to go in the opposite direction along route "C".
5. Once you are aligned with route "C" and are a distant of one spread width from the edge, reopen the gate and travel straight along Route "C". Again, ensure there is no gap between route "B" & "C".
6. Repeat Steps 4 & 5 until you have covered the entire area.

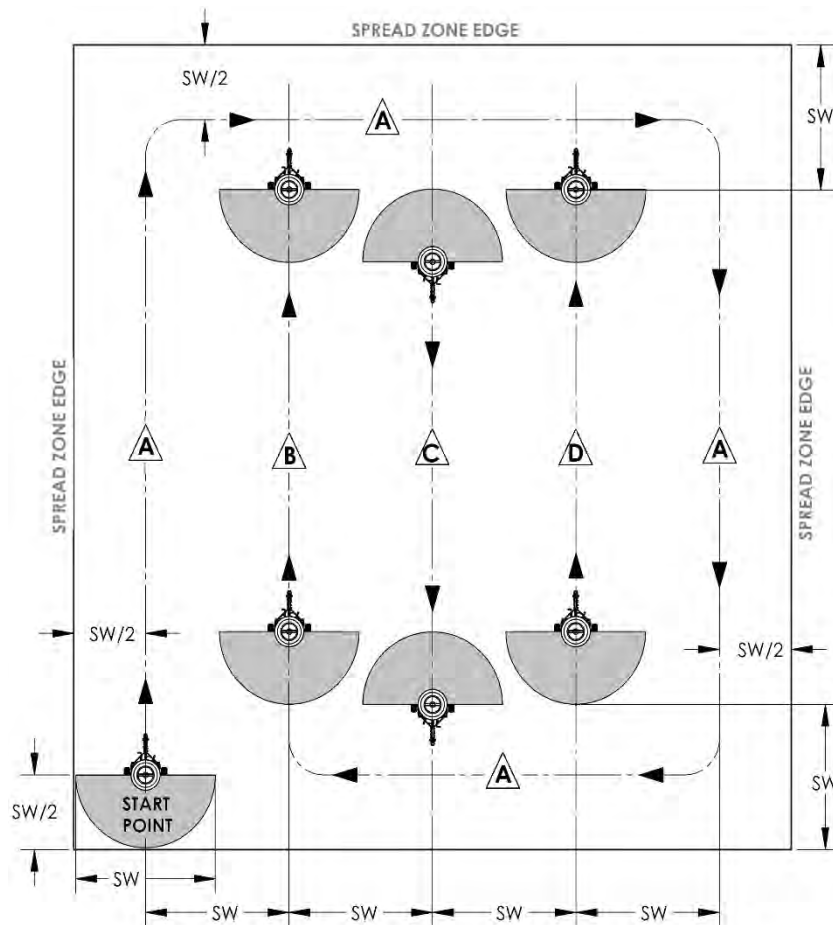

FIGURE 20.1

"SW" = Spread Width
"SW/2" = Half Spread Width

SPREADER MAINTENANCE

GENERAL RECOMMENDATIONS

The warranty on this Spreader does **not** cover items that have been subjected to operator abuse or negligence. To receive full value from the warranty, operator must maintain unit as instructed in this manual.

Some adjustments will need to be made periodically to maintain your unit properly.

BEFORE EACH SEASON

- Check the UHMW Washer (21967) for wear, replace if needed. See **Page 31**
- Check for Gearbox oil leaks.
 - If a leak is found, remove Gearbox from the spreader and check oil levels. Replace/add if oil is low or dirty. There should be 12oz of SAE 90 or 80W90 gear oil in the gearbox.
- Check Wheel Bearings for failure or damage.
- Check Operation of All Controls.
- Check tires for wear and damage.
- Replace Agitator Cotter Pin (10936). See **Page 31**

BEFORE EACH USE

- Check all Hardware for Looseness or Damage.
- Check Tires for proper inflation.
- Ensure axle Pin is either in the holding location or the Axle Coupler.
- Lubricate threads of Top Link (P/N 21103) if needed.

AFTER EACH USE

- Check all Hardware for Looseness or Damage.
- Check Tires for proper inflation.
- **Clean Thoroughly.** Refer to page 21 for cleaning guide.

Important: Replace parts that have been damaged.

Important: Check Disc and Hopper mounting hardware on a regular basis to make sure it is tight.



CAUTION: CARELESS OR IMPROPER HANDLING MAY RESULT IN SERIOUS INJURY.

CLEANING GUIDELINES



WARNING: PROPER CLEANING IS ONE OF THE MOST IMPORTANT STEPS IN CARING FOR YOUR SPREADER. SOME MATERIALS CAN BE HIGHLY CORROSIVE AND **WILL CAUSE DAMAGE TO SPREADER COMPONENTS IF NOT CLEANED !**

GENERAL RECOMMENDATIONS

- Always thoroughly clean the spreader after every use.
- Use fresh clean water to clean.
- Allow to completely dry before using after cleaning.

CLEANING THE HOPPER

- Empty all bulk material left in the Hopper.
- Remove the Removable Pin from the top link located next the Flow Control Handle . This will Allow the Hopper to lower and become easier to access for cleaning. **See FIGURE 22.1 & 22.2**
- Using clean water and a rag. Thoroughly clean the inside of the Hopper and all Components. It may be necessary to remove the agitator to clean particles that may be trapped underneath.
- Also thoroughly clean the slide plates, spinner disc, and gearbox.
- Check the internal plastic sealing washer (Part # 21967) for damage and clean all debris that may have gotten under the washer. See page 31 for washer detail.
- Once the Hopper is clean, if cleaned with water, make sure it is completely dry before adding material. Wet material can result in poor function and corrosion.

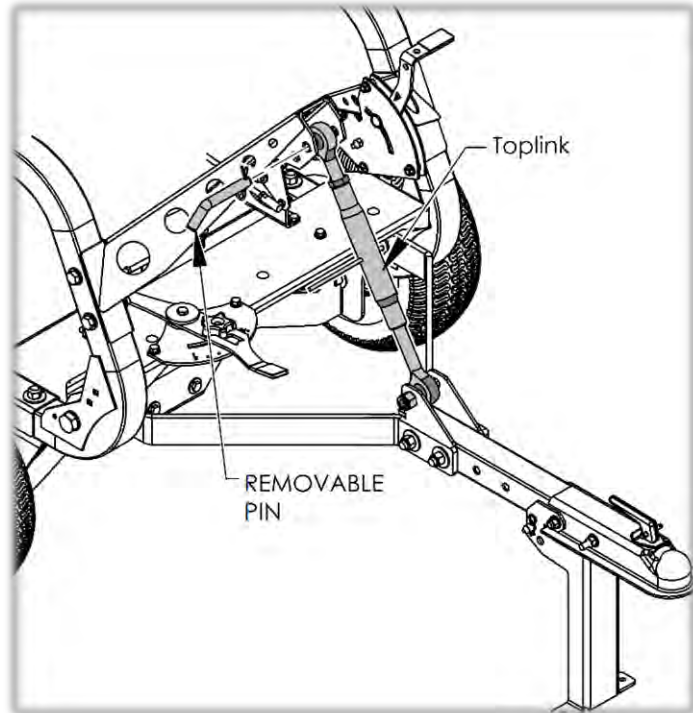

FIGURE 22.1

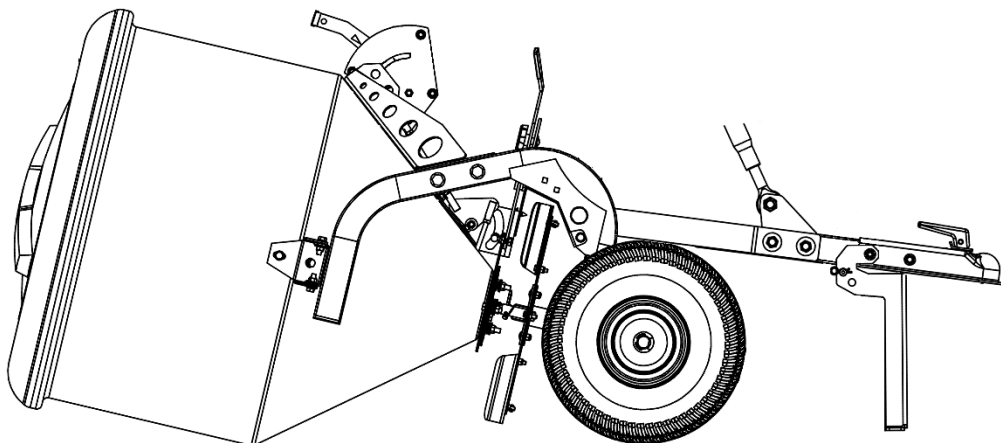

FIGURE 22.2

TROUBLESHOOTING

ISSUE	SOLUTION
Disc Will Not Spin	Check that the Axle Engagement Pin is in Place.
	Check Axle or Coupler for possible Damage.
	Ensure Key is in the Wheel
	Check Gear Box For Damage.
	Ensure Key and Set screw are in place on Axle Coupler
	Ensure Key and Set Screw are in place on the Disc Coupler
The Unit is Not Spreading Level	Ensure the Spreading Disc is level with the ground by adjusting the top link.
	Check Tire pressure and for tire/wheel damage.
Material Will Not Flow	Check that the Control Handle is Open to the desired Flow Level.
	Check Linkages between slide plates and Control Handle.
	Check for Opening Slot Blockages.
	Ensure Slide Plates move when operating the Control Handles.
Drive Tire Will Not Spin	Check for Material Jamming the internal Agitator.
	Check for Damage Axle Bearings
	Make sure all Moving Parts are Free of Debris.
Agitator Will Not Spin	Check that the Cotter Pin is in place and not damaged.
	Check for that the Axle Pin is place.
	Ensure Agitator shaft is not damaged or broken.
Handle Will Not Move	Check Linkage Rods and Ball Joints.
	Check slide plates for damage/blockages.
	Check Handle for damage.



IF PROBLEMS PERSIST HAVE A QUALIFIED MECHANIC SERVICE THE SPREADER. NEVER ATTEMPT TO MAKE AN ADJUSTMENT THAT YOU ARE NOT SURE IS CORRECT. DOING SO CAN CAUSE OTHER PROBLEMS.

PARTS DIAGRAMS

FRAME ASSEMBLY

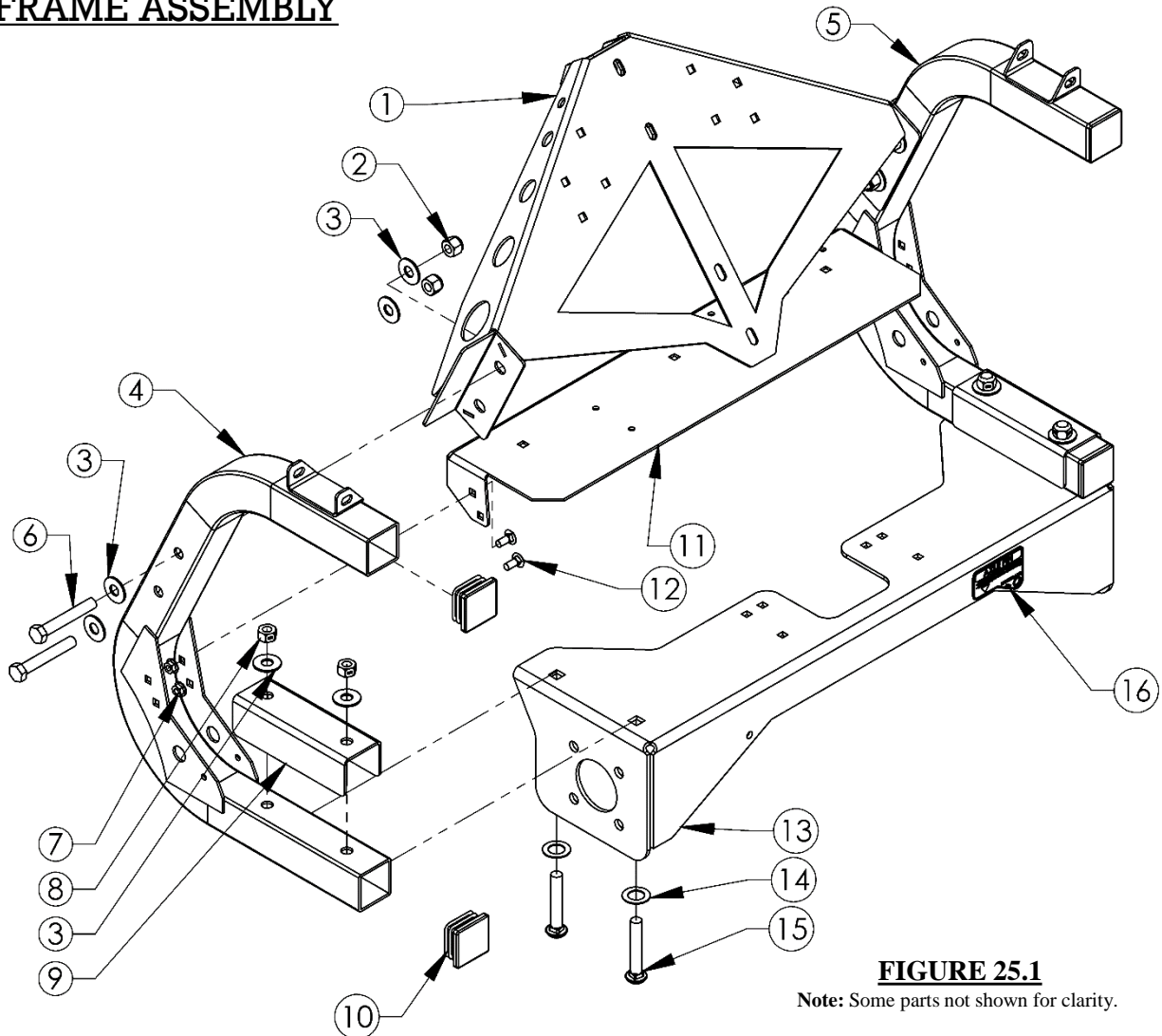

FIGURE 25.1

Note: Some parts not shown for clarity.

ITEM #	DESCRIPTION	PART #	QTY
1	WELDMENT - HOPPER SUPPORT	21959*	1
2	NUT- 1/2-13 NYLON LOCK	NB281	4
3	WASHER - 1/2 USS FLAT	18823	12
4	WELDMENT - FRAME ARM, LEFT	21941*	1
5	WELDMENT - FRAME ARM, RIGHT	21983*	1
6	BOLT - 1/2-13 X 3 1/4	12669	4
7	NUT - 5/16-18 SERR FLANGE	NB170	4
8	NUT - 1/2-13, 2-WAY LOCK	12165	4
9	BRACKET - FRAME, 2" SQ TUBE CLAMP	21938*	2
10	PLUG, FINISHING - 1 X 3 X .083 TUBE	50062009	4
11	WELDMENT - CONTROL SUPPORT	21962*	1
12	BOLT - CARRIAGE, 5/16-18 X 3/4	10216	4
13	WELDMENT - SPREADER BASE FRAME	21943*	1
14	WASHER - 3/4 ID X 1 1/4 OD 18 GA	NB179	4
15	BOLT - CARRIAGE, 1/2 X 3"	10500	4
16	DECAL - AXLE PIN	21914	1

PARTS DIAGRAMS

GEARBOX ASSEMBLY

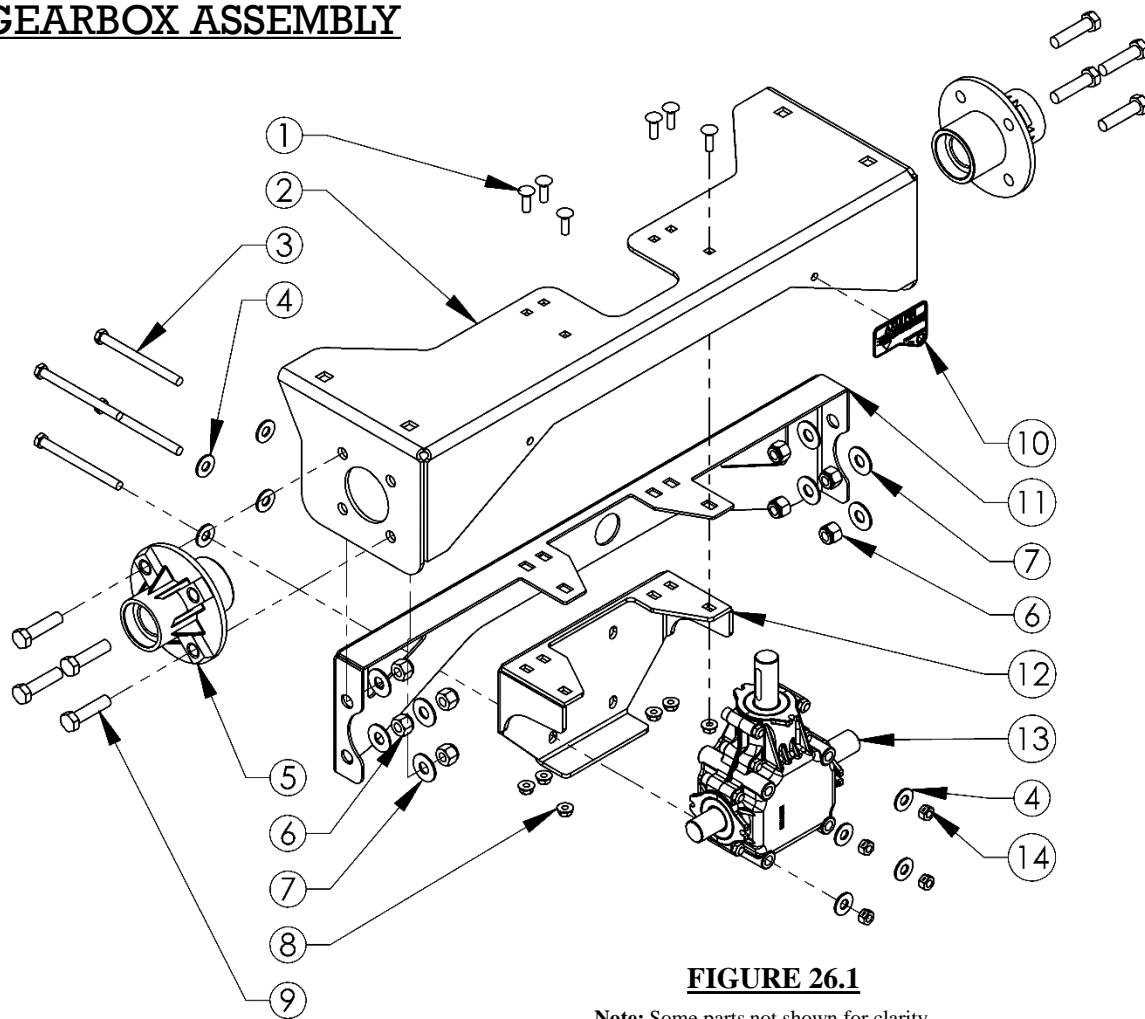

FIGURE 26.1

Note: Some parts not shown for clarity.

ITEM #	DESCRIPTION	PART #	QTY
1	BOLT - CARRIAGE, 5/16"-18x1"	10197	6
2	WELDMENT - BASE FRAME	21943*	1
3	BOLT - HEX, 3/8"-16x4 1/2"	NB674	4
4	WASHER - FLAT 3/8"	NB271	8
5	BEARING HOUSING - CAST	4858*	2
6	NUT - NYLON LOCK, 1/2"-13	NB281	8
7	WASHER - FLAT, 1/2"	NB555	8
8	NUT - SERR FLANGE, 5/16"-18	NB170	6
9	BOLT - HEX, 1/2"-13x2"	NB509	8
10	DECAL - AXLE PIN	21914	1
11	WELDMENT - BASE SUPPORT	21984*	1
12	WELDMENT - GEARBOX MOUNT	21944*	1
13	GEARBOX	21394	1
14	NUT - 2-WAY LOCK, 3/8-16	NB280	4

PARTS DIAGRAMS

TIRE & AXLE ASSEMBLY

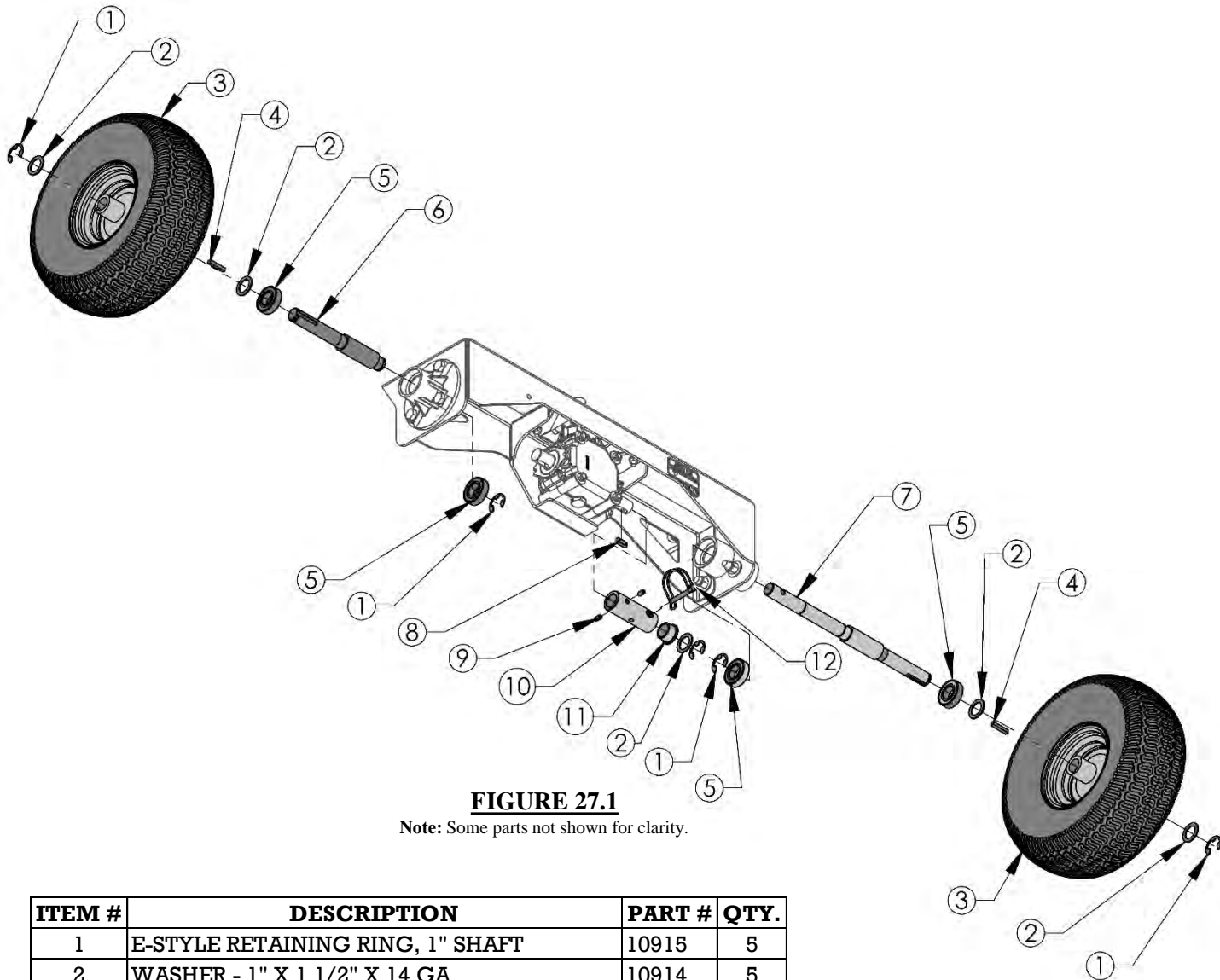

FIGURE 27.1

Note: Some parts not shown for clarity.

ITEM #	DESCRIPTION	PART #	QTY.
1	E-STYLE RETAINING RING, 1" SHAFT	10915	5
2	WASHER - 1" X 1 1/2" X 14 GA	10914	5
3	TIRE/WHEEL - 15X6.00-6 , 4 PLY, BLK	21934	2
4	KEYSTOCK - 1/4" X 1 1/2"	2437	2
5	BLADE BEARING, Ø1ID X Ø2OD	4845	4
6	SHAFT - AXLE, 1" OD, 8 15/16" LNG	21968Z	1
7	SHAFT - DRIVE AXLE, 1" OD	21953Z	1
8	KEY - 8MM X 25MM LONG	21991	1
9	SCREW - SET 5/16-18 X 1/2 W/ LOCTITE	NB312	2
10	COUPLER - GEARBOX SHAFT ADAPTOR	21956Z	1
11	BEARING - FLANGE SLEEVE, 1"ID X 1.25"OD	22001	1
12	PIN - 5/16" OD LOCKING	21986	1

PARTS DIAGRAMS

HITCH ASSEMBLY

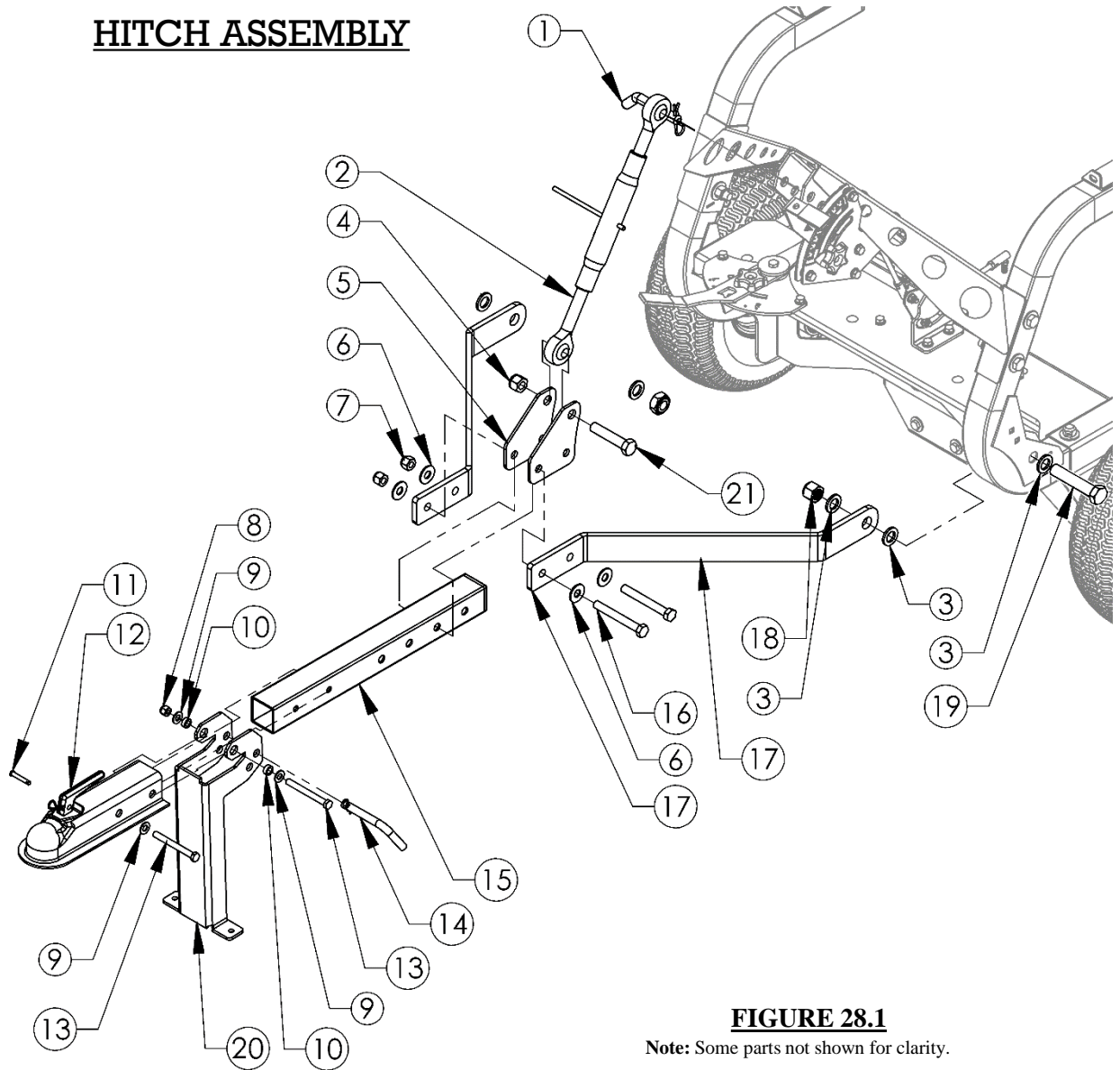

FIGURE 28.1

Note: Some parts not shown for clarity.

ITEM	DESCRIPTION	PART #	QTY.
1	PIN - 5/8" X 3" W/ HAIRCLIP	NB702	1
2	TOP LINK	21103	1
3	WASHER - 3/4"ID X 1 1/4"OD	NB184	6
4	NUT - 5/8"-11 NYLON LOCK	21138	1
5	PLATE - TOP LINK HITCH BRACKET	21950*	2
6	WASHER - 1/2" USS FLAT	NB555	4
7	NUT - 1/2"-13 NYLON LOCK	NB281	2
8	NUT - 3/8"-16 NYLON LOCK	NB182	2
9	WASHER - 3/8" WASHER	NB272	4
10	BUSHING	7840Z	2

ITEM	DESCRIPTION	PART #	QTY.
11	PIN - 1/4" X 1 1/2" CLEVIS	NB518	1
12	COUPLER - 2" BALL	7365	1
13	BOLT - HEX, 3/8-16 X 3 1/2	NB649	2
14	PIN - 1/2" X 3" W/HAIR CLIP	NB606	1
15	TUBE - SPREADER HITCH BAR	21946*	1
16	BOLT - 1/2"-13 X 4" HCC	NB132	2
17	PLATE - HITCH ARM	21951*	2
18	NUT - 3/4"-10 NYLON LOCK	NB313	1
19	BOLT - 3/4"-10 X 3 3/4"	21129	2
20	HITCH STAND - BLACK	21954*	1
21	BOLT - 5/8-11 X 3"	NB699	1

PARTS DIAGRAMS

SPINNER DISC ASSEMBLY

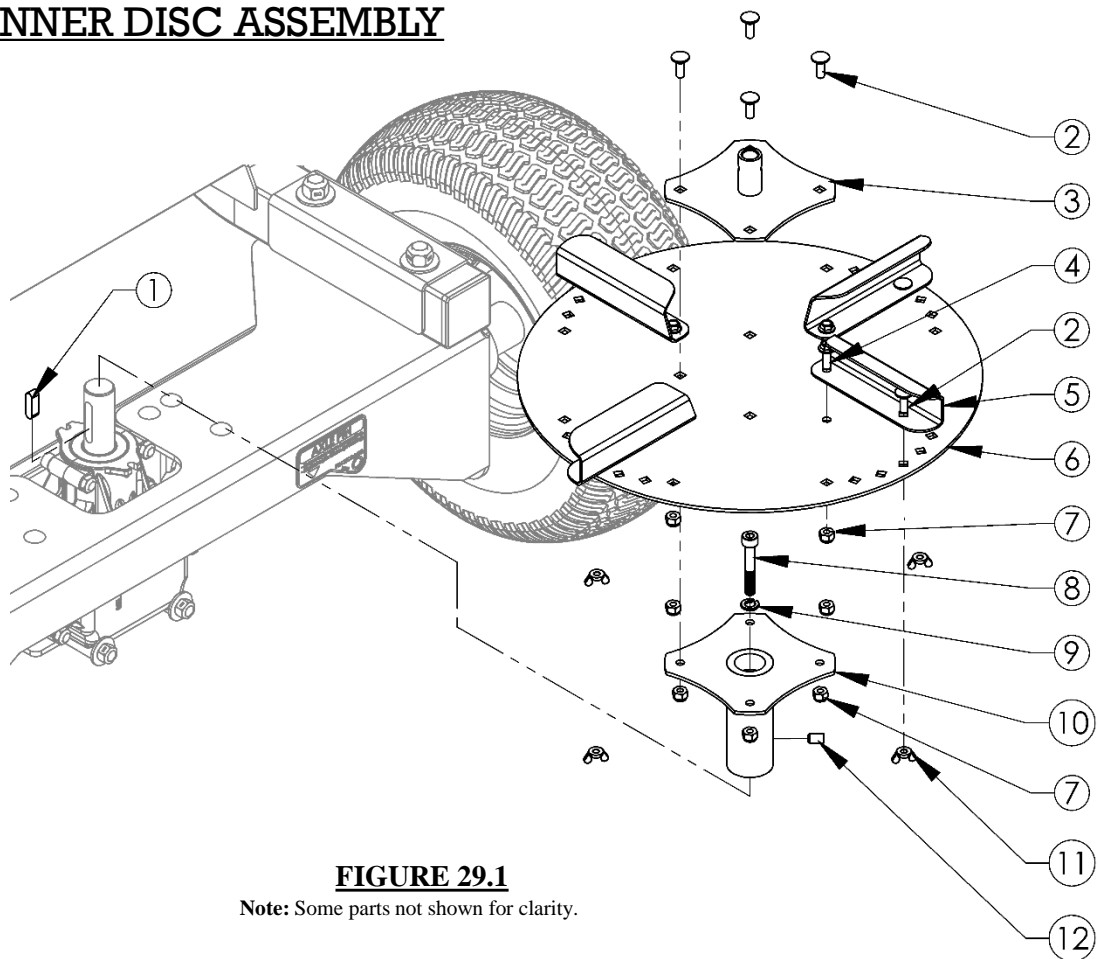

FIGURE 29.1

Note: Some parts not shown for clarity.

ITEM	DESCRIPTION	PART #	QTY.
1	KEY - 8mm x 25mm LONG, ROUNDED	21991	1
2	BOLT - 1/4 - 20 x 3/4 , CARRIAGE	22611	8
3	WELDMENT - AGITATOR SHAFT MOUNT	21975GV	1
4	BOLT - 1/4-20 X 3/4, SERR FLANGE	22612	4
5	PLATE - SPINNER ARM	21939GV	4
6	PLATE - SPINNER DISC	21948GV	1
7	NUT - 1/4-20, NYLON LOCK	22613	8
8	SCREW- SOCKET HEAD, M8X1.25X50MM	21993	1
9	WASHER - SPLIT LOCK 5/16	NB159	7
10	WELDMENT - SPINNER DISC	21947*	1
11	NUT - WING , 1/4-20	22614	4
12	SET SCREW - 5/16-18, LOCTITE	NB312	1

PARTS DIAGRAMS

DEBRIS GUARD

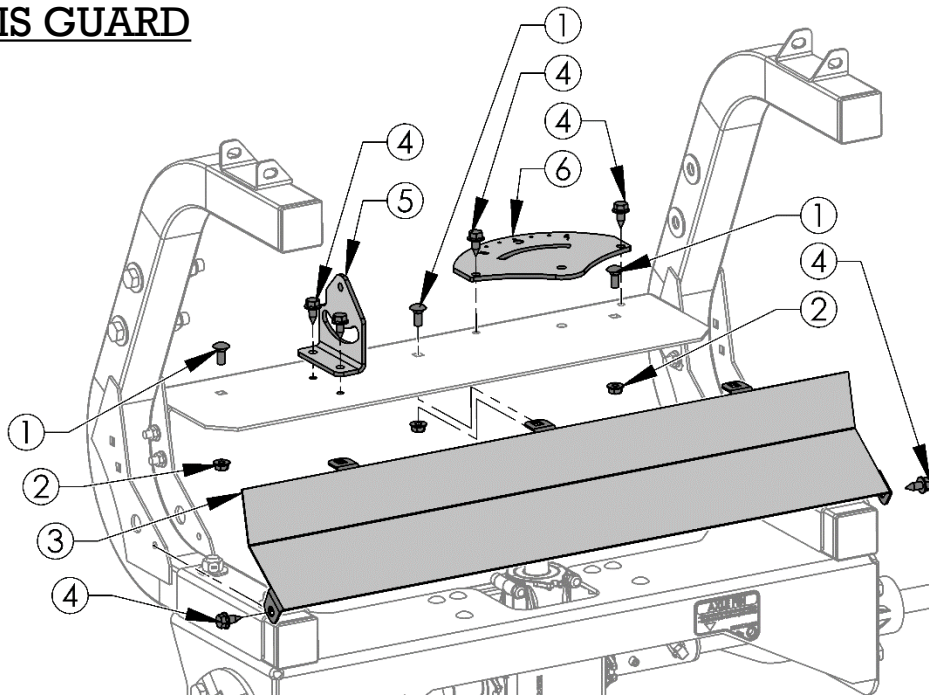

FIGURE 30.1

Note: Some parts not shown for clarity.

ITEM	DESCRIPTION	PART #	QTY
1	BOLT - CARRIAGE, 5/16-18 x 3/4"	10216	3
2	NUT - 5/16-18, SERR FLANGE	NB170	3
3	GUARD - DEBRIS SHEILD	21987*	1
4	SCREW - 5/16-18 X .3/4, BLACK	26X249	6
5	BRACKET - OPEN PIVOT	21979*	1
6	PLATE - OFFSET HANDLE BASE	21971*	1

OFFSET GATE CONTROL

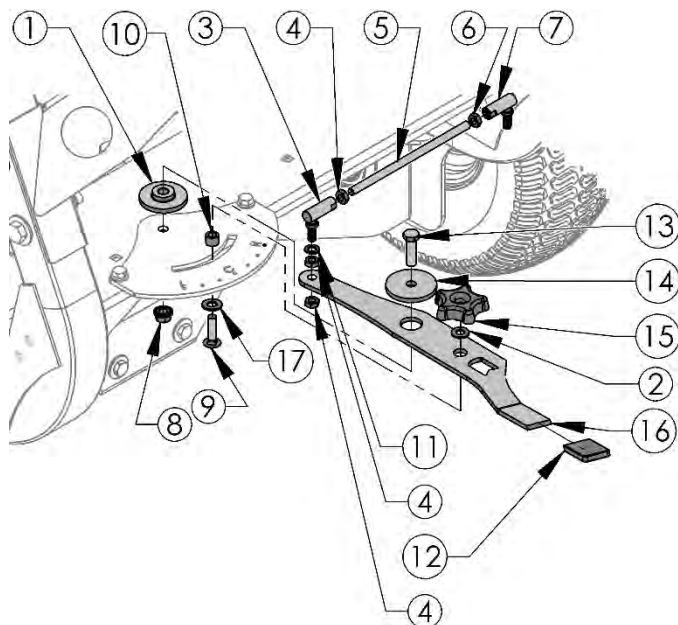

FIGURE 30.2

Note: Some parts not shown for clarity.

When ordering replacement parts

* = USE PAINT CODE: TK=BLACK

ITEM	DESCRIPTION	PART #	QTY
1	BUSHING	6037	1
2	WASHER - 5/16" SAE	NB275	1
3	BALL JOINT - RHT, 5/16-24	NB263	1
4	NUT - JAM, 5/16"-24 ZY	NB190	3
5	LINKAGE - 5/16-24 LHT & RHT, 6.5"	20753	1
6	NUT - JAM, 5/16"-24 ZY, LHT	NB265	1
7	BALL JOINT - LHT, 5/16-24	NB264	1
8	NUT - 3/8-16 , SERR FLANGE	NB779	1
9	BOLT - 5/16-18 X 1 1/4", CARRIAGE	10217	1
10	BUSHING - 1/2" OD	7825Z	1
11	WASHER - 5/16" , SPLIT LOCK	NB159	1
12	GRIP - HANDLE, ORANGE	19911	1
13	BOLT - 3/8-16 X 1 1/4", HEX	NB618	1
14	WASHER - BUSHING, 3/8" ID ZP	6040Z	1
15	KNOB - PLASTIC, BLACK	2030	1
16	HANDLE - L/R/C OFFSET	21970*	1
17	WASHER - 1/2" 14 GA SS	22620	1

PARTS DIAGRAMS

FLOW GATE CONTROL

ITEM #	DESCRIPTION	PART #	QTY
1	BALL JOINT - RHT, 5/16-24	NB263	1
2	NUT - JAM, 5/16"-24 ZY	NB190	2
3	LINKAGE - 5/16-24 LHT & RHT, 6.5"	20753	1
4	NUT - JAM, 5/16"-24 ZY, LHT	NB265	1
5	BALL JOINT - LHT, 5/16-24	NB264	1
6	NUT - 5/16-18 SERR FLANGE	NB170	5
7	WASHER - SPLIT LOCK 5/16 ZY	NB159	5
8	BUSHING - 5/16 ID X 1/2 OD	7825Z	5
9	SPACER - FENDER	18717	1
10	INDICATOR - OPENER LOCATION	21981*	1
11	PIVOT HANDLE GRIP	19911	1
12	WASHER - NYLON 1/2"ID X 7/8"OD	NB682	2
13	DECAL - OPENING INDICATOR, 0-4	21985	1
14	BRACKET - OPEN HANDLE, FRONT	21982*	1
15	BOLT - 5/16-18 x 1 SERR FLG	10548	3
16	KNOB - 5/16-18 OPEN, BLACK	2030	1
17	BOLT - 5/16-18 X 1 1/4", SERR FLNG	NB253	1
18	NUT - 5/16-18 NYLON LOCK	22609	1
19	BOLT - 5/16-18 X 1 1/4, CARRIAGE	10217	1
20	WASHER - 1/2" 14 GA SS	22620	1
21	BRACKET - OPEN HANDLE, BACK	21980*	1
22	HANDLE - SPREADER, OPEN-CLOSE	21976*	1

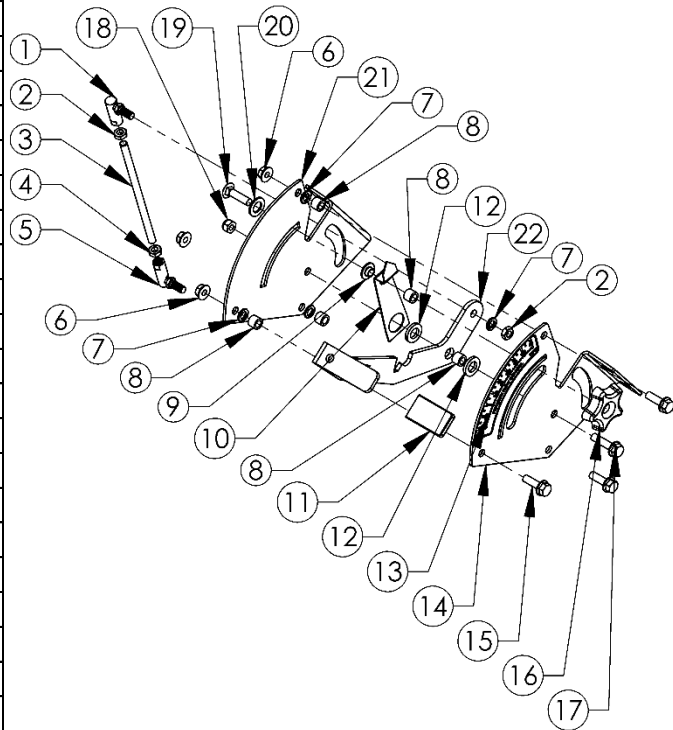

FIGURE 31.1

Note: Some parts not shown for clarity.

CONTROL ASSEMBLY

ITEM #	DESCRIPTION	PART #	QTY
1	BOLT - 5/16-18 X 3/4, CARRIAGE	10216	4
2	BOLT - 5/16-18 X 1, SERR FLANGE	10548	1
3	WASHER - NYLON 1/2"ID X 7/8"OD	NB682	2
4	BALL JOINT - LHT, 5/16-24	NB264	1
5	NUT - JAM, 5/16"-24 ZY, LHT	NB265	1
6	LINKAGE - 5/16-24 LHT & RHT, 6.5"	20753	1
7	NUT - JAM, 5/16"-24 ZY	NB190	3
8	NUT - 5/16-18 NYLON LOCK	22609	1
9	BALL JOINT - RHT, 5/16-24	NB263	1
10	PLATE - SLIDE PIVOT, BLACK	21978*	1
11	WASHER - SPLIT LOCK 5/16 ZY	NB159	2
12	BUSHING - 5/16 ID X 1/2 OD	7825Z	1
13	NUT - 5/16-18 SERR FLANGE	NB170	4

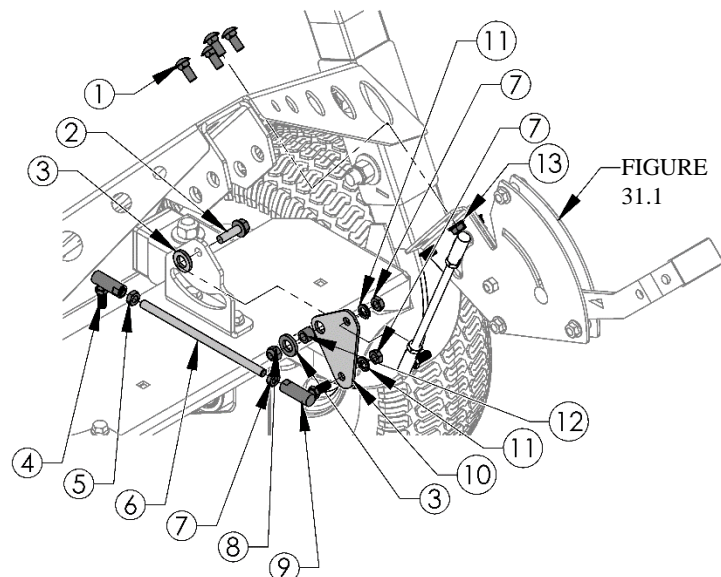
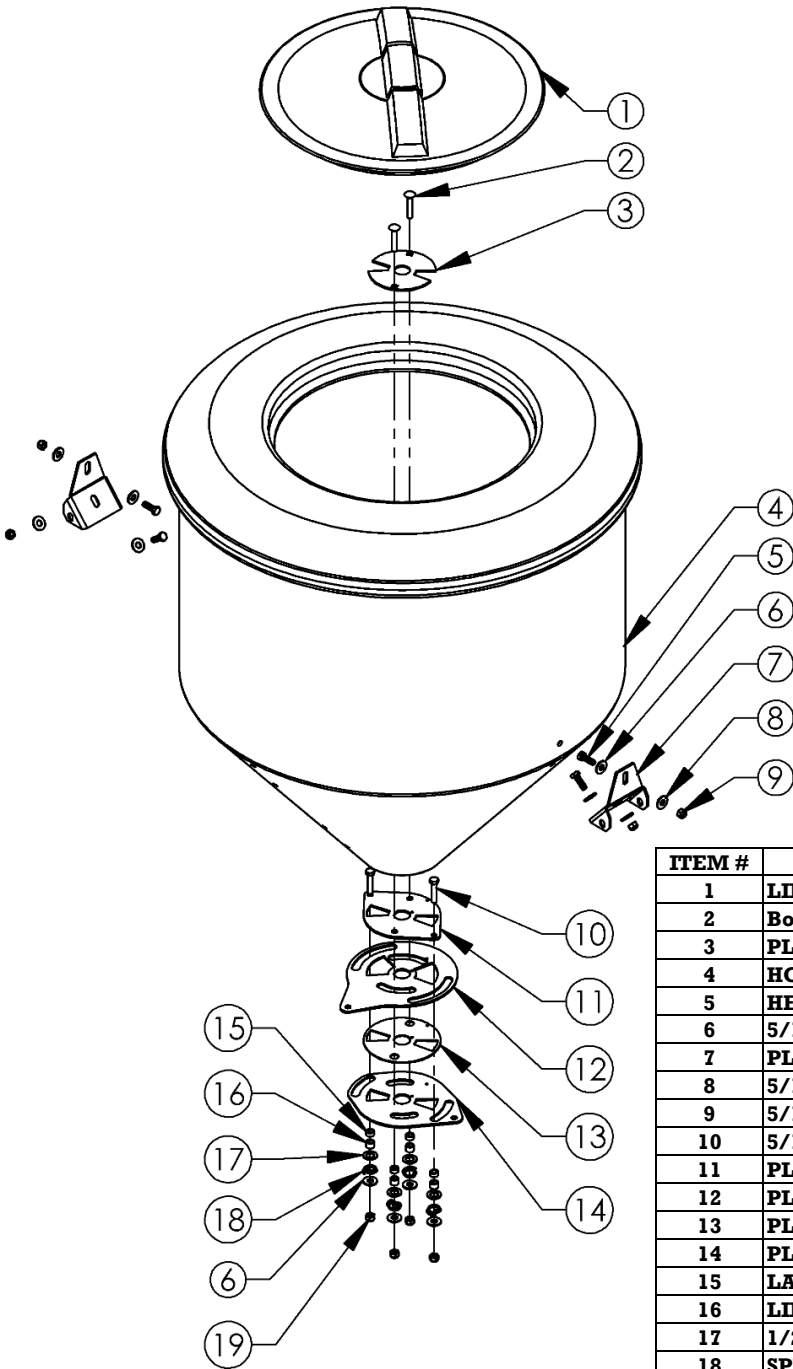

FIGURE 31.2

Note: Some parts not shown for clarity.

HOPPER ASSEMBLY



ITEM #	DESCRIPTION	PART #	QTY.
1	LID - HOPPER, TOW SPREADER, 16"	22124	1
2	Bolt - CARRAIGE ; 5/16-18 X 1.75 ; SS	22619	2
3	PLATE - HOPPER MOUNT, INNER PLATE	21972GV	1
4	HOPPER - 52 GALLON, HPDE, MOLDED	21935	1
5	HEX HEAD BOLT, 5/16-18 X 1" SS	24325	4
6	5/16 USS FLAT WASHER SS	22607	8
7	PLATE - HOPPER MOUNT BRACKET, BOLT	21965*	2
8	5/16 USS FLAT WASHER	NB556	4
9	5/16-18 NYLOC NUT	NB181	4
10	5/16-18 X 1.50 BOLT SS	22608	2
11	PLATE - SLIDE PLATE, HOPPER MOUNT	21933GV	1
12	PLATE - SPREADER, OFFSET HOLE	21936GV	1
13	PLATE - SLIDE DISC SPACER	21973GV	1
14	PLATE - SPREADER, SLIDE OPENER	21937GV	1
15	LATCH PIN BUSHING	7839Z	4
16	LIFT BAR BUSHING	7825Z	4
17	1/2 NR MACHINE BUSHING 14 GA ; SS	22620	4
18	SPRING	22610	4
19	5/16-18 NYLOC NUT SS	22609	4

FIGURE 32.1

Note: Some parts not shown for clarity.

HOPPER MOUNTING ASSEMBLY

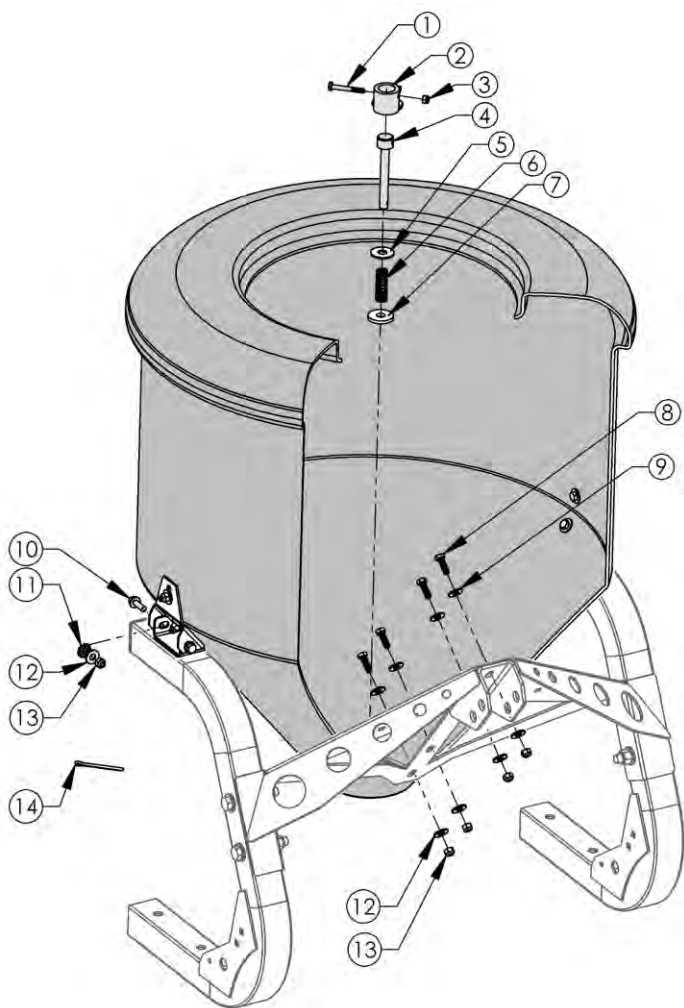

ITEM.#	DESCRIPTION	PART #	QTY.
1	BOLT - 1/4-20 X 2" SS	24326	1
2	AGITATOR	21989GV	1
3	Nut - 1/4-20 Nylok SS	22613	1
4	SHAFT - INTERNAL AGITATOR	21955GV	1
5	WASHER - 1/2 USS FLAT SS	22605	1
6	SPRING - COMPRESSION	12364	1
7	WASHER - PLASTIC, 3/16" THK, 1/2" ID	21967	1
8	BOLT, 5/16-18 X 1" SS	24325	8
9	WASHER - 5/16 USS FLAT SS	22607	8
10	BOLT 5/16-18 x 1 SERR FLANGE	10548	4
11	WASHER - STAR 5/16	NB742	4
12	WASHER - 5/16 USS FLAT	NB556	12
13	NUT - 5/16-18 NYLOC	NB181	12
14	PIN - COTTER, 3/16 X 2-1/4	19036	1

FIGURE 33.1

Note: Some parts not shown for clarity.

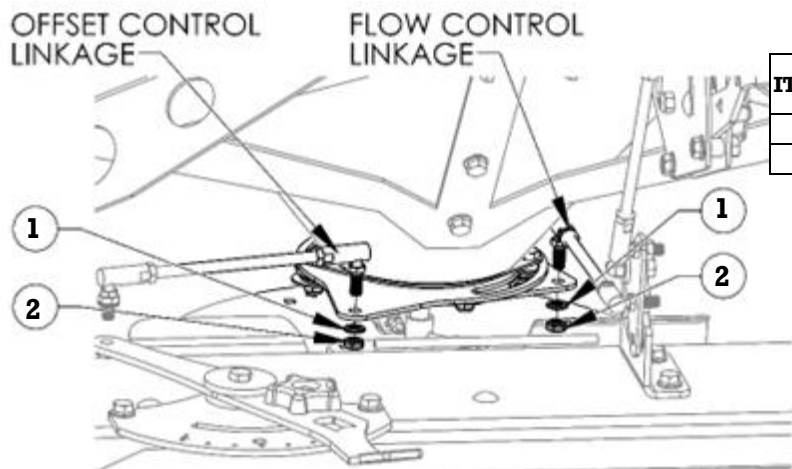

ITEM.#	DESCRIPTION	PART #	QTY.
1	Washer - Split Lock 5/16 ZY	NB159	2
2	Nut - Jam 5/16-24 ZY	NB190	2

FIGURE 33.2

Note: Some parts not shown for clarity.

CALCULATING MATERIAL FLOW

GENERAL RECOMMENDATIONS

- The chart in **figure 32.2** only represents general guidelines for certain material flow rates. Many factors affect how a material will spread including, but not limited to, moisture content, ambient temperature, humidity, weather conditions, brand of medium, and many more.
- For the most accurate distribution of material, always calculate the flow rates of the material being spread.

Calculating Material Flow

- Fill the Hopper with a known weight of the desired material. (ex. 20 lbs of seed)
 - There is a graduated scale on the Hopper. The units of measurement are Gallons and Liters. For conversion of Gallons to other units of volume measurement use the Conversion Chart **FIGURE 32.1**.
- Place a tarp under the spreader base to catch the dropped material for re-use.
- Open the control gate to any desired number and time (seconds) how long it takes for all the material to leave the hopper. This will give you how many pounds/second at the setting indicated on the handle decal.
- Next it is recommended to refill the same amount of material into the Spreader. Find an area to spread this material where you can see the spread width. Pull the unit at the desired speed (recommended 3-5 MPH) to achieve the spread width that is desired. The faster the unit is pulled the wider the material will be spread. The slower the unit is pulled, the narrower the material will spread.
- Once you have determined your desired pulling speed, material spread width, and material flow rate you can calculate the pounds per acre for accurate coverage. Use the work sheet and notes on **pages 30-32** to log and record flow rates for future use.

HOPPER VOLUME CONVERSION		
GALLONS	BUSHELL	CUBIC FEET
4	0.43	0.53
6	0.64	0.80
8	0.86	1.07
12	1.29	1.60
16	1.72	2.14
20	2.15	2.67
24	2.58	3.21
28	3.01	3.74
32	3.44	4.28
36	3.87	4.81
40	4.30	5.35
44	4.73	5.88
46	4.94	6.15
48	5.16	6.42
52	5.59	6.95

FIGURE 32.1

GENERAL MATERIAL FLOW RATES						
MATERIAL	SPEED (MPH)	WIDTH (FT)	POUNDS /ACRE @ DIFFERENT FLOW CONTROL SETTINGS			
			1	2	3	4
SAND	3	14	115	405	675	991
	5	22	55	200	495	631
ROCK SALT (1/4" min)	3	16	-	85	215	379
	5	26	-	35	105	140
RED CLOVER	3	18	21	151	364	438
	5	28	9	58	140	175
FESCUE	3	12	-	65	190	295
	5	18	-	25	80	100
RYE	3	11	-	68	195	300
	5	18	-	26	91	110

FIGURE 32.2

TORQUE SPECIFICATIONS REFERENCE GUIDE

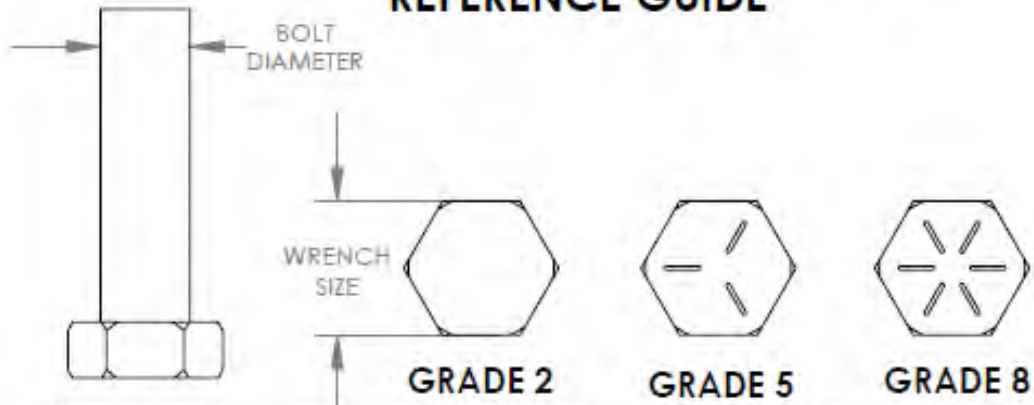

Bolt Diameter (INCH)	Wrench Size	SAE GRADE 2		SAE GRADE 5		SAE GRADE 8	
		lb-ft	(Nm)	lb-ft	(Nm)	lb-ft	(Nm)
1/4	7/16	5.5	(7)	9	(12)	12.5	(17)
5/16	1/2	11	(15)	18	(24)	26	(35)
3/8	9/16	20	(27)	33	(45)	46	(62)
7/16	5/8	32	(43)	52	(70)	75	(102)
1/2	3/4	50	(68)	80	(108)	115	(156)
9/16	7/8	70	(95)	115	(156)	160	(217)
5/8	15/16	100	(136)	160	(217)	225	(305)
3/4	1-1/8	175	(237)	280	(380)	400	(542)
7/8	1-5/16	175	(237)	450	(610)	500	(678)
1	1-1/2	270	(366)	540	(732)	750	(1017)
1-1/8	1-11/16	300	(407)	675	(915)	1075	(1457)
1-1/4	1-7/8	425	(576)	950	(1288)	1500	(2034)

Torque values are for reference. 10% variance is allowable. Use these values unless specific torque values are given for a specific application.

Fasteners should be replaced with the same grade. Make sure fasteners threads are clean and that you properly start thread engagement. This will prevent them from failing when tightening.

Tighten toothed or serrated-type lock nuts to the full torque value.

SUGGESTED GUIDE FOR SIGHTING SLOPES FOR SAFE OPERATION

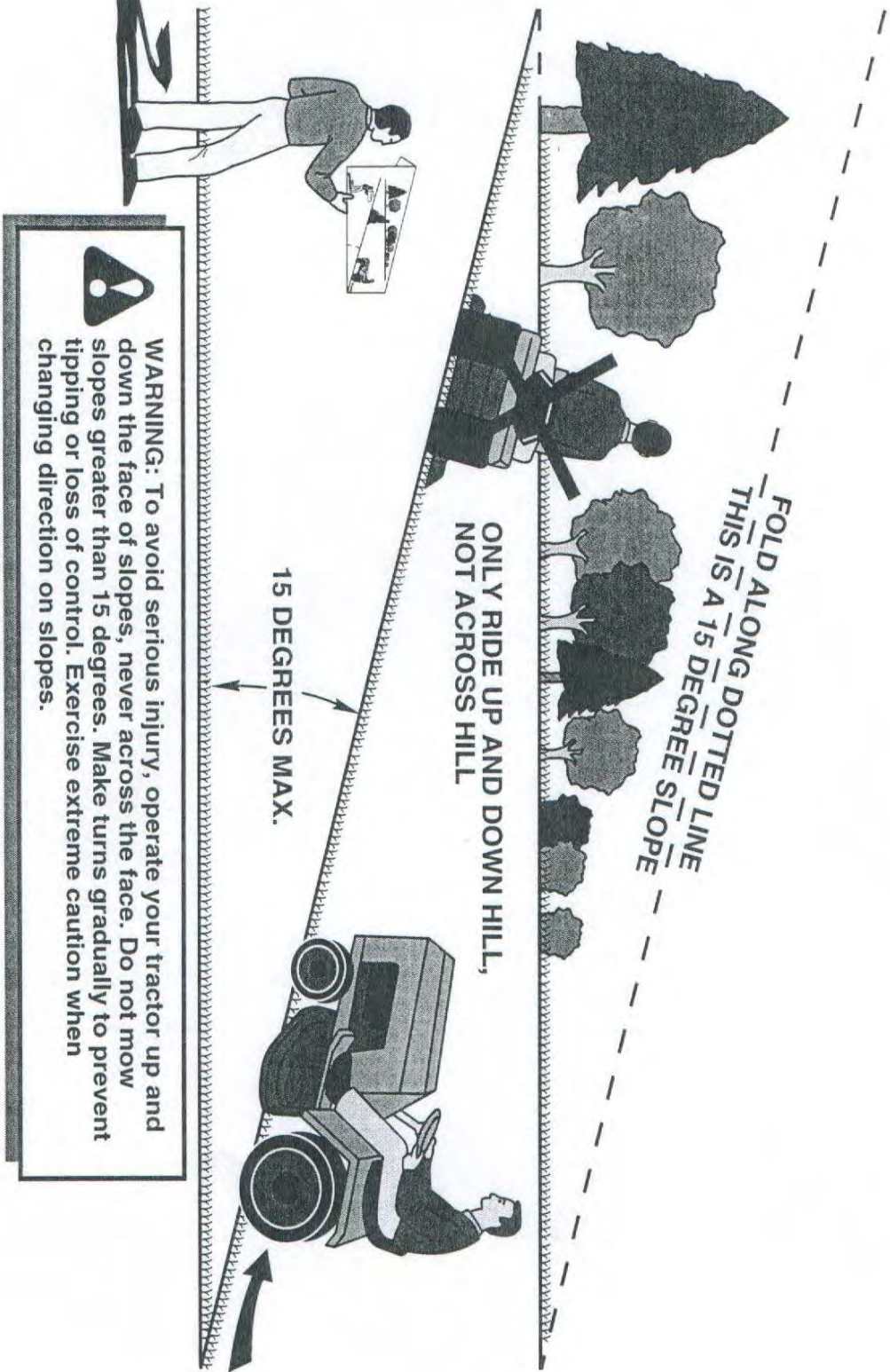

1. Fold this page along dotted line indicated above.
2. Hold page before you so that its left edge is vertically parallel to a tree trunk or other upright structure.
3. Sight across the fold in the direction of hill slope you want to measure.
4. Compare the angle of the fold with the slope of the hill.

www.swisherinc.com

OWNER'S MANUAL

MODEL NO.

22000



IMPORTANT

**Read and follow all
Safety Precautions
and Instructions
before operating this
equipment.**

Hobby Farms Pro Tow Spreader

Each Spreader has its own model number. The model number for the Spreader will be found on the left hand side of the control mount platform. The model number for the gearbox will be found on the face of the gearbox.

All Spreader parts listed herein may be ordered directly from Swisher or your nearest Swisher dealer.

WHEN ORDERING PARTS, PLEASE HAVE THE
FOLLOWING INFORMATION AVAILABLE:

- * PRODUCT – HOBBY FARM PRO TOW SPREADER
- * SERIAL NUMBER - _____
- * MODEL NUMBER - _____
- * GEARBOX MODEL NUMBER - _____
- * PART NUMBER
- * PART DESCRIPTION

TELEPHONE - 1-800-222-8183

FAX - 1-660-747-8650

SWISHER ACQUISITION INC.

1602 CORPORATE DRIVE

WARRENSBURG, MO 64093

www.swisherinc.com

SWISHER®

CHANGING YOUR LANDSCAPE SINCE 1945