

WOOD CHIPPER

Assembly

► Model: B150

⚠ WARNING



ALWAYS READ THE USER MANUAL CAREFULLY AND FOLLOW THE SAFETY INSTRUCTIONS

Scan to view the installation video.



Required

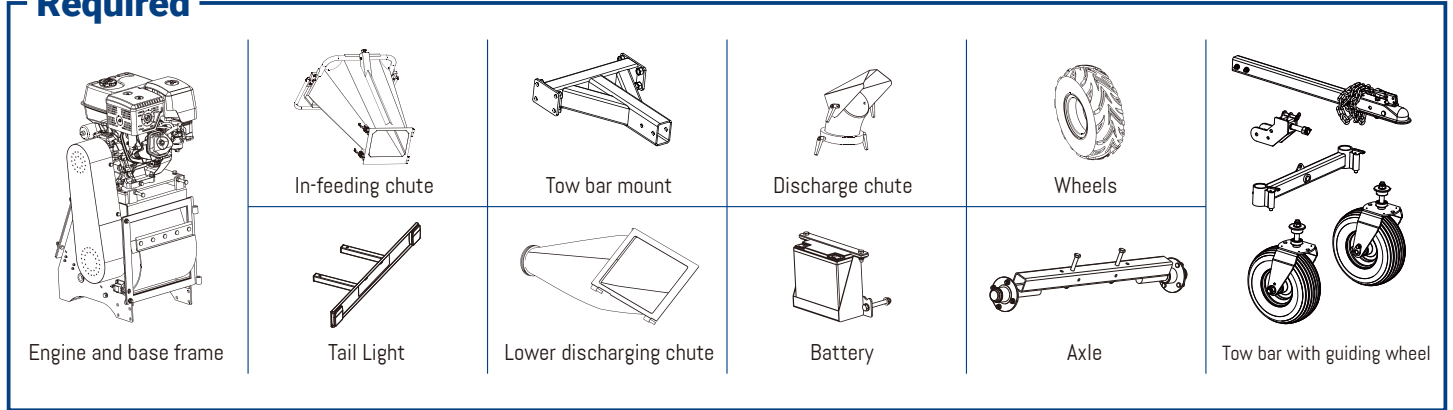

01. Axle

Attach the wheel axle to the cutter base using M14×140 Hex Bolts (B), Flat Washer 14 (C), and M14 Lock Nuts (A).

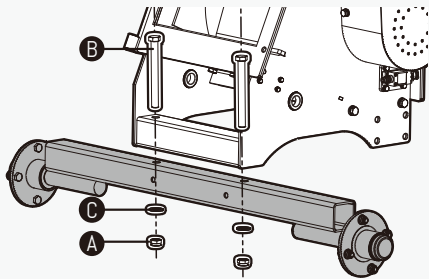

A	Hex lock nut M14		x 2
B	Hex bolt M14 X 140mm		x 2
C	Flat washer 14		x 2

02. Wheels

Attach the wheels to the wheel axles using M10×25 Hex Bolts (B), Flat Washer 10 (C), and M10 Lock Nuts (A).

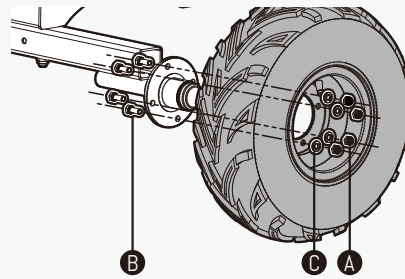

A	Hex lock nut M10		x 8
B	Hex bolt M10 X 25mm		x 8
C	Flat washer 10		x 8

03. Tow bar mount

Attach the tow bar mount to the base frame using M12×35 Hex Bolts (B), Spring Washer 12 (A), and Flat Washer 12 (C).

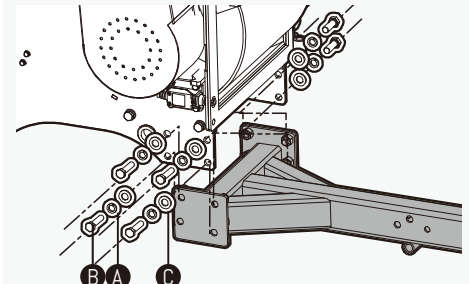

A	Spring washer 12		x 8
B	Hex bolt M12 X 35mm		x 8
C	Flat washer 12		x 8

04. Tow bar and Guiding wheel

1. Attach the pivoted axle to the tow bar mount using M10×80 Hex Bolts (B), Flat Washer 10 (C), M10 Lock Nuts (A), and D Pin Ø5×30 (D).

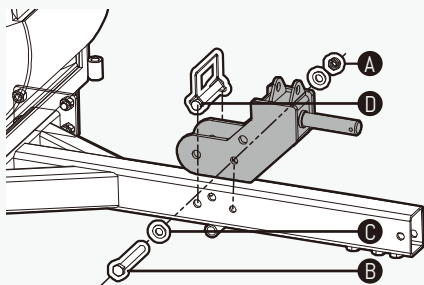

A	Hex lock nut M10		x 1
B	Hex bolt M10 X 80mm		x 1
C	Flat washer 10		x 2
D	D Pin Ø5×30		x 1

2. First, install the steering wheel onto the front wheel axle using M16 Hex Lock Nuts (A), Flat Washer 16 (C), Stamped End Cover (D), and Flat Washer 20 (B). Then, attach the front wheel axle to the pivoted axle using M20×2 Fine Thread (E) and Cotter Pin Ø5×32 (F).

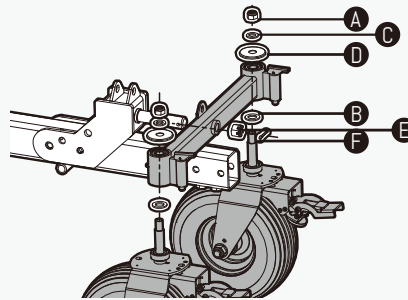

A	Hex lock nut M16		x 1
B	Flat washer 20		x 1
C	Flat washer 16		x 1
D	Stamped End Cover		x 1
E	Fine Thread M20×2		x 1
F	Cotter Pin Ø5×32		x 1

Secure the front wheel axle again using Pin Shaft 12×75 (A), Flat Washer 12 (B), and R Pin (C). Then, assemble the tow bar onto the pivoted axle using M10×70 Hex Bolts (D), Flat Washer 10 (E) and M12 Nuts (F).

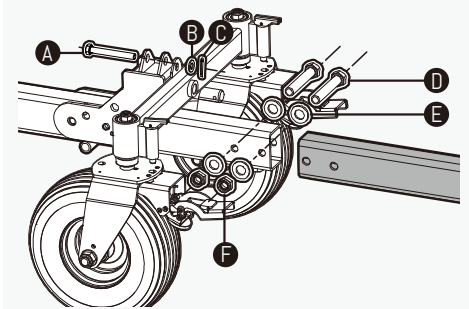

A	Pin Shaft 12x75		x 1
B	Flat washer 12		x 1
C	R Pin		x 1
D	Hex bolt M10x70		x 2
E	Flat washer 10		x 4
F	Lock nut M10		x 2

05. Lower expulsion chute

Assemble the Lower Expulsion Chute onto the base frame using Flat Washer 12 (C), Pin Shaft $\varnothing 12 \times 70$ (B), and Cotter Pin $\varnothing 3.2 \times 22$ (A).

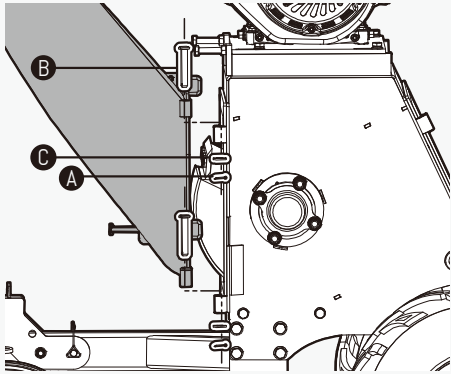

A	Cotter Pin $\varnothing 3.2 \times 22$	x 2
B	Pin Shaft $\varnothing 12 \times 70$	x 2
C	Flat Washer 12	x 2

Attach the lower expulsion chute to the cutter base using two lock catches.

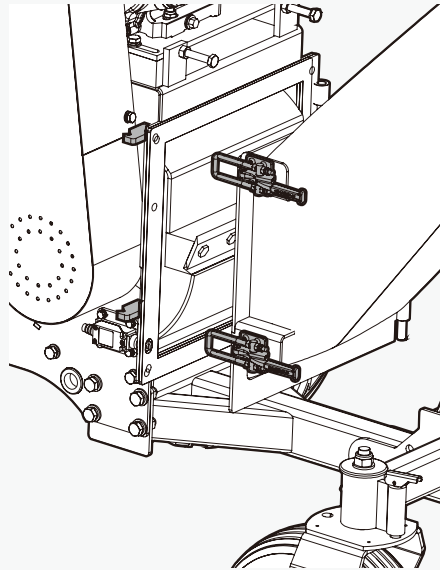

06. 360-degree upper expulsion chute

Attach the upper expulsion chute to the lower expulsion chute using the Clamp Handle (A).

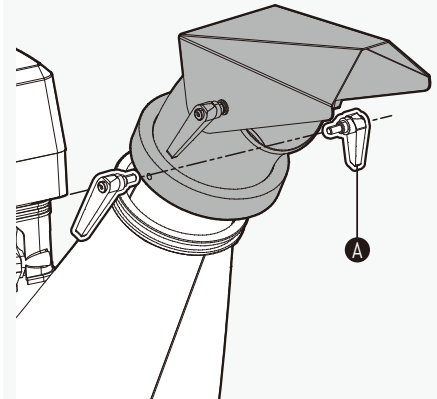

A	Clamp handle	x 2
----------	--------------	-----

07. Battery

Attach the battery box to the wheel axle using M10 \times 80 Hex Bolts (B), Flat Washer 10 (C), and M10 Lock Nuts (A).

Connect the battery cables: red to the positive terminal and black to the negative terminal.

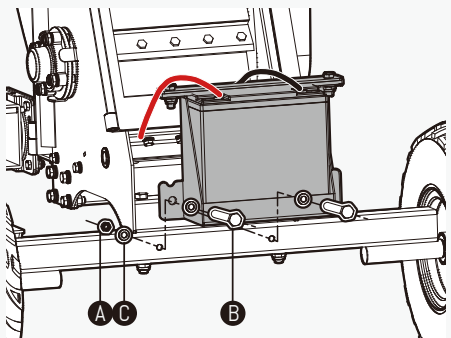

A	Hex lock nut M10	x 2
B	Hex bolt M10 X 80mm	x 2
C	Flat washer 10	x 4

08. Infeed chute

Assemble the Infeed Chute onto the base frame using Flat Washer 12 (C), Pin Shaft $\varnothing 12 \times 70$ (B), and Cotter Pin $\varnothing 3.2 \times 22$ (A).

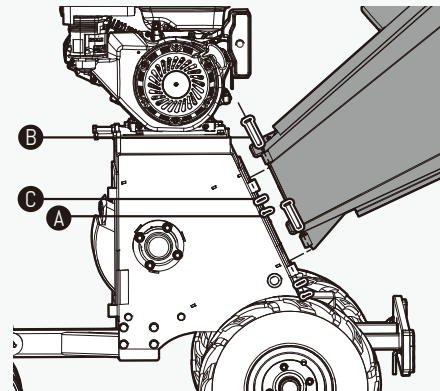

A	Cotter Pin $\varnothing 3.2 \times 22$	x 2
B	Pin Shaft $\varnothing 12 \times 70$	x 2
C	Flat Washer 12	x 2

Attach the feeding chute to the cutter base using the two lock catches.

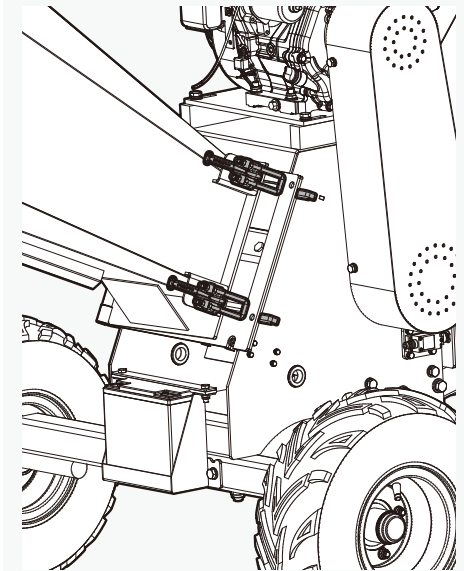

09. Tail Light

Attach the taillights to the shaft using M12 \times 120 hex bolts (B), M12 hex lock nuts (A), and 12 flat washers (C).

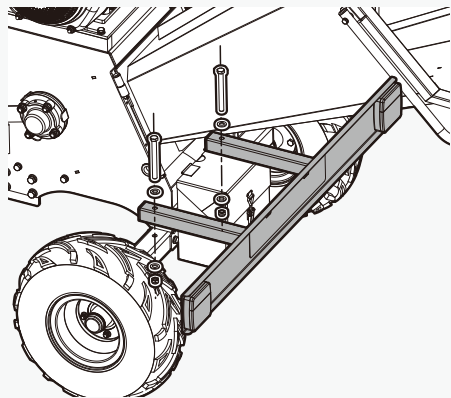

A	Hex lock nut M12	x 2
B	Hex bolt M12 X 120mm	x 2
C	Flat washer 12	x 4

10. Emergency Stop and Limit Switch

The emergency stop switch and the limit switch require four connections using 2-pin connectors. All four connections follow the same procedure and can be connected in any order.

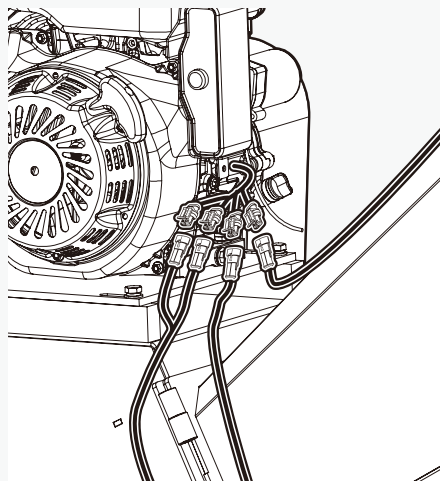

11. Taillight line

For the taillight wiring, route the wires through the bottom of the wood chipper and then into the tow bar. Connect the 7-pin plug to the towing vehicle. At the rear of the taillights, use the rotary connectors to join the two taillight wires.

