

D50MA MINI DUMPER



Operator's Manual

MechMaxx

www.mechmaxx.com

TABLE OF CONTENTS

TABLE OF CONTENTS	1	MAINTENANCE	14
SPECIFICATIONS	2	PREVENTIVE MAINTENANCE	14
SAFETY SIGNS	3	ADJUSTING CLUTCH	14
SAFETY	4	ADJUSTING STEERING	14
UNDERSTAND YOUR MACHINE	4	REPLACING DRIVE BELT	15
PERSONAL SAFETY	4	GENERAL LUBRICATION	15
INSPECT YOUR MACHINE	4	GEARBOX LUBRICATION	15
ENGINE SAFETY	4	TIGHTENING TRACKS	16
FUEL SAFETY	5	REPLACING TRACKS	17
SPECIFIC SAFETY RULES	5	ENGINE MAINTENANCE	18
UNPACHING THE CONTAINER	7	STORAGE	19
CONTENTS SUPPLIED	8	TROUBLESHOOTING	20
KNOW YOUR MACHINE	9		
OPERATION	12		
ADD OIL TO ENGINE	12		
ADD GASOLINE TO ENGINE	12		
STARTING ENGINE	12		
OPERATING	13		
IDLE SPEED	13		
STOP ENGINE	13		

SPECIFICATIONS

Model	D50MA
Engine	Rato
Engine Type	Single cylinder,4 stroke, air-cooled,OHV
Engine Displacement	212cc
Horsepower	7hp
Power	4.1kw/3600rpm
Transmission	Transaxle 3 forward/1 reverse speed
Working Pressure	16.5Mpa
Driven Type	Track
Track Roller	4 pcs
Track Tensioning	Yes
Bucket Capacity	1100 lbs
Box Size	38*27*19 in

SAFETY SIGNS

The rating plate on your machine may show symbols. These represent important information about the product or instructions on its use.

⚠ WARNING ⚠

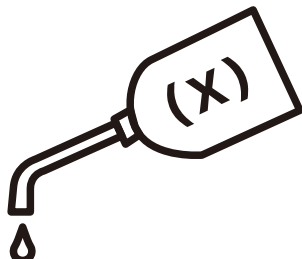

- After first 30 hours use, change all the gear oil. Capacity is 1.5L.
- For future use, check the oil level after every 30 hours of use. If you remove the oil level plug and no oil flows out, please add oil and then screw the oil level plug.
- Gear oil GL-5 or GL-6, SAE80W-90 is recommended. Do not use synthetic oil.

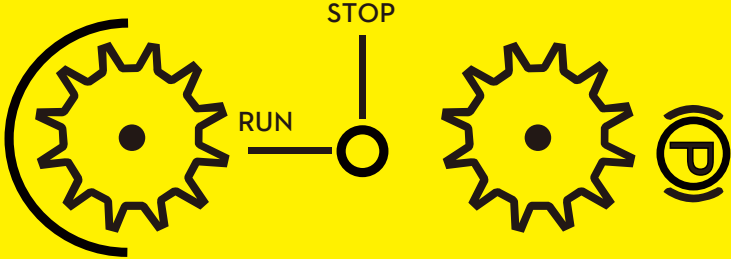

WARNING: OPERATE THE STEERING LEVERS ONLY AT A REDUCED SPEED



⚠ WARNING ⚠

OPERATE THE STEERING LEVERS ONLY AT A LOW SPEED.

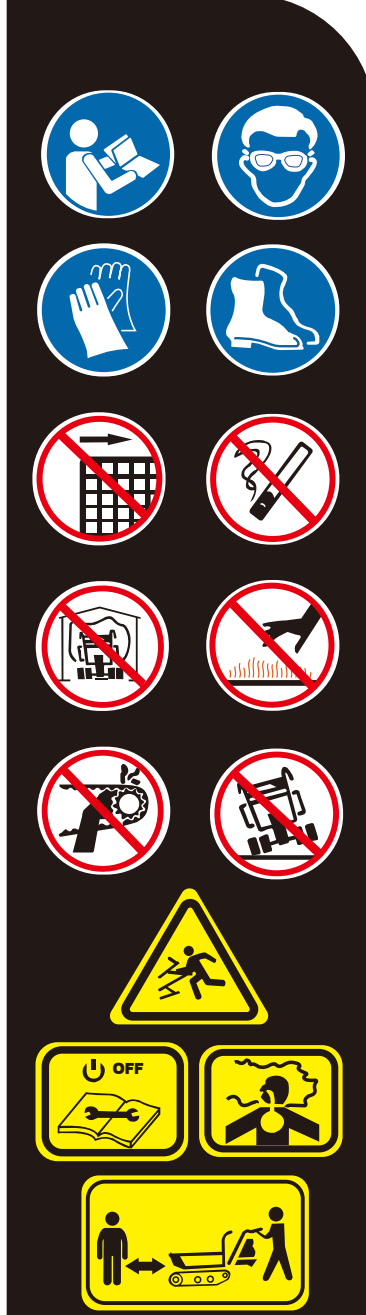

SAFETY

UNDERSTAND YOUR MACHINE

Read this manual and labels affixed to the machine to understand its limitations and potential hazards.

Be thoroughly familiar with the controls and their proper operation. Know how to stop the machine and disengage the controls quickly.

Make sure to read and understand all the instructions and safety precautions as outlined in the Engine Manufacturer's manual packed separately with your unit. Do not attempt to operate the machine until you fully understand how to properly operate and maintain the engine and know how to avoid accidental injuries and/or property damage.

If the unit is to be used by someone other than original purchaser, or is to be loaned, rented, or sold, always provide this manual and any needed safety training before operation. The user can prevent and is responsible for accidents or injuries that may occur to themselves, to other people, or to property.

Do not force the machine beyond its limits. Use the correct machine for your application.

PERSONAL SAFETY

Do not permit children to operate this machine at any time.

Keep children, pets, and other people not using the unit away from the work area. Be alert and shut off the unit if anyone enters work area. Keep children under the watchful care of a responsible adult.

Do not operate the machine while under the influence of drugs, alcohol, or any medication that could affect your ability to use it properly.

Dress properly: Wear long, heavy pants, work boots, and work gloves. Do not wear loose clothing, short pants, or jewelry of any kind. Secure long hair so it is above shoulder level. Keep your hair, clothing, and gloves away from moving parts. Loose clothes, jewelry, or long hair can be caught in moving parts.

Protect eyes, face, and head from objects that may be thrown from the unit. Always wear safety goggles or safety glasses with side shields when operating.

Wear appropriate hearing protection.

Always keep hands and feet away from all moving parts during operation. Moving parts can cut or crush body parts.

Always keep hands and feet away from all pinch points.

Do not touch parts that might be hot from operation. Allow parts to cool before attempting to maintain, adjust, or service.

Stay alert, watch what you are doing, and use common sense when operating the machine.

Do not overreach. Do not operate the machine while barefoot or when wearing sandals or similar lightweight footwear. Wear protective footwear that will protect your feet and improve your footing on slippery surfaces. Keep proper footing and balance at all times. This enables better control of the machine in unexpected situations.

INSPECT YOUR MACHINE

Check your machine before starting it. Keep guards in place and in working order. Make sure all nuts, bolts, etc., are securely tightened.

Never operate the machine when it is in need of repair or is in poor mechanical condition. Replace damaged, missing, or failed parts before using it. Check for fuel leaks. Keep the machine in safe working condition.

Do not use the machine if the engine's switch does not turn off the engine when running. Any gasoline powered machine that can't be controlled with the engine switch is dangerous and must be replaced.

Regularly check to see that keys and adjusting wrenches are removed from the machine area before starting it. A wrench or a key that is left attached to a rotating part of the machine may result in personal injury.

Avoid accidental starting. Be sure the engine's switch is off before transporting the machine or performing any maintenance or service on the unit. Transporting or performing maintenance or service on a machine with its switch on invites accidents.

If the machine should start to vibrate abnormally, stop the engine (motor) and check immediately for the cause. Vibration is generally a warning sign of trouble.

ENGINE SAFETY

This machine is equipped with an internal combustion engine. Do not use on, or near, forest-covered or brush-covered land unless the exhaust system is equipped with a spark arrester meeting applicable local, state, or federal laws.

In the state of California, a spark arrester is required by law. Other states have similar laws. A spark arrester, if used, must be maintained in effective working order by the operator.

Never start or run the engine inside a closed area. The exhaust fumes are dangerous, containing carbon monoxide, an odorless and deadly gas. Operate this unit only in a well ventilated outdoor area.

Do not tamper with the engine in an effort to get it to run at higher speeds. The maximum engine speed is preset by the manufacturer and is within safety limits. See engine manual.

Keep a Class B fire extinguisher on hand when operating this machine in dry areas as a precautionary measure.

FUEL SAFETY

Fuel is highly flammable, and its vapors can explode if ignited. Take precautions when using to reduce the chance of serious personal injury.

When refilling or draining the fuel tank, use an approved fuel storage container while in a clean, well-ventilated outdoor area. While adding fuel or operating the unit, do not smoke, and stay away from sparks, open flames, or other sources of ignition near the area of operation. Never fill the fuel tank indoors.

To avoid sparking or arcing, keep grounded conductive objects - such as tools - away from exposed, live electrical parts and connections. These events could ignite fumes or vapors.

Always stop the engine and allow it to cool before filling the fuel tank. Never remove the cap of the fuel tank or add fuel while the engine is running or when the engine is hot. Do not operate the machine with known leaks in the fuel system.

Loosen the fuel tank cap slowly to relieve any pressure in the tank.

Never overfill the fuel tank. Because engine heat can cause fuel to expand, never fill the tank to more than 1/2" below the bottom of the filler neck. This will provide space for fuel expansion.

Replace all fuel tank and container caps securely and wipe up spilled fuel. Never operate the unit without the fuel cap securely in place.

Avoid creating a source of ignition for spilled fuel. If fuel is spilled, do not attempt to start the engine. Instead, move the machine away from the area of spillage and avoid creating any source of ignition until fuel vapors have dissipated.

When fuel is spilled on yourself or your clothes, wash your skin and change clothes immediately.

Store fuel in containers specifically designed and approved for fuel storage.

Store fuel in a cool, well-ventilated area, safely away from sparks, open flames, or other sources of ignition.

Never store fuel - or a machine with fuel in the tank - inside a building where fumes may reach a spark, open flame, or any other source of ignition (such as a water heater, furnace, or clothes dryer). Allow the engine to cool before storing in any enclosure.

SPECIFIC SAFETY RULES

Thoroughly inspect the area to be worked. Keep the working area clean and free of debris to prevent tripping. Operate on flat, level ground.

Never place any part of your body where it would be in danger if movement should occur during assembly, installation, operation, maintenance, repair, or relocation.

Keep all bystanders, children, and pets at least 23m away. If you are approached, stop the unit immediately.

Do not mount anything on the hopper and never carry passengers.

Never park the machine in a place with unstable ground that could give way, particularly when it is full.

Disengage clutch lever before starting the engine.

Start the engine carefully according to instructions and with feet away from the moving parts.

Never leave the operating position when the engine is running.

Always hold the unit with both hands when operating. Keep a firm grip on the handlebars. Be aware that the machine may unexpectedly bounce upward or jump forward if the machine should strike buried obstacles such as large rocks or roots.

Walk, never run with the machine.

Do not overload the machine capacity. Always drive at a safe speed, and adjust the speed to the slope of the land, the surface conditions of the road, and the weight of the load.

Use extreme caution when in reverse or pulling the machine towards you.

Exercise extreme caution when operating on or crossing gravel drives, walks, or roads. Stay alert for hidden hazards or traffic.

On soft ground, drive at the first forward/ reverse gear. Do not rapidly accelerate, turn sharply or stop.

Pay the utmost attention when working on frozen ground, as the machine may tend to skid.

Do not operate the machine in confined areas where there may be a risk of crushing the operator between the machine and another object.

Never operate the machine on slopes where angle is over 20°.

When operating on a slope, whether moving forward or in reverse, always make certain that the weight is evenly balanced. Always operate the machine straight up or down slopes, never drive sideways or across the slope. Do not shift gears on slopes.

When dumping the contents of the hopper, the center of gravity will change continuously and the ground conditions will be essential for the stability of the machine. Use extra caution and control when dumping the hopper on unstable ground, such as wet clay or soil.

UNPACHING THE CONTAINER

Use the screwdriver and hammer to open all the side locks.

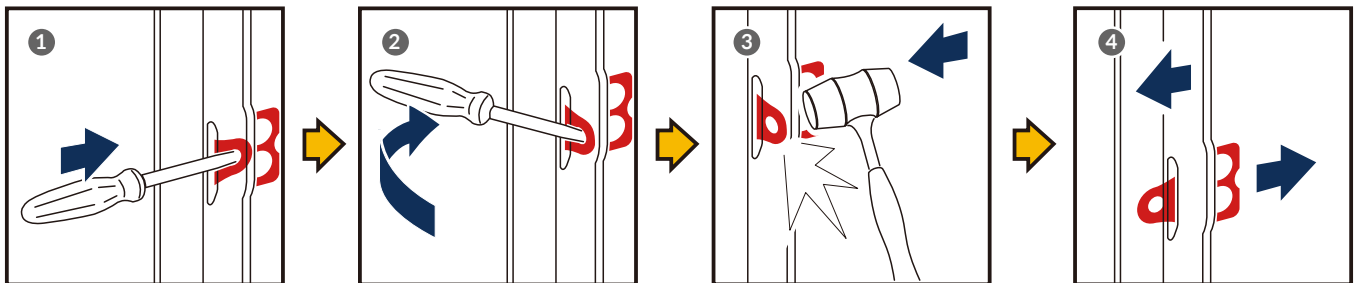
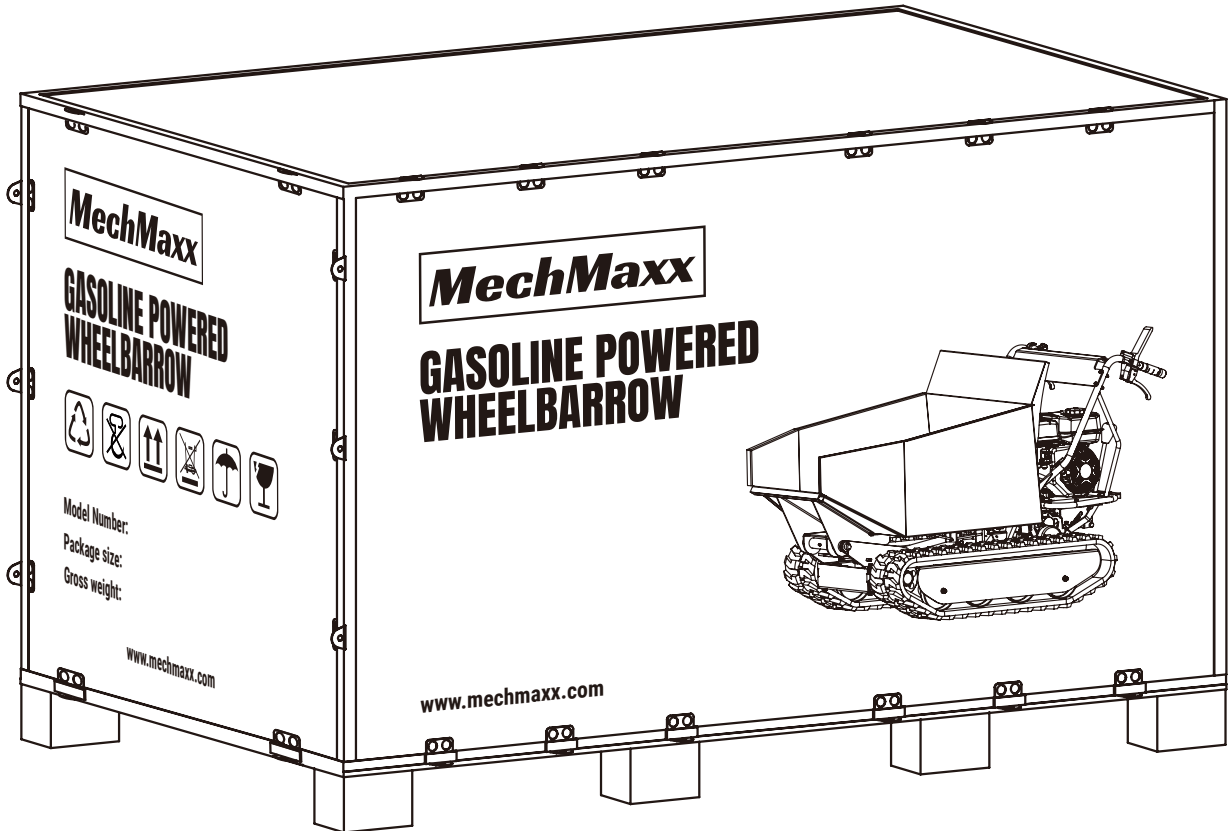

CONTENTS SUPPLIED

The mini tracked dumper comes partially assembled and is shipped in carefully packed package. After all the parts have been removed from the package, you should have:

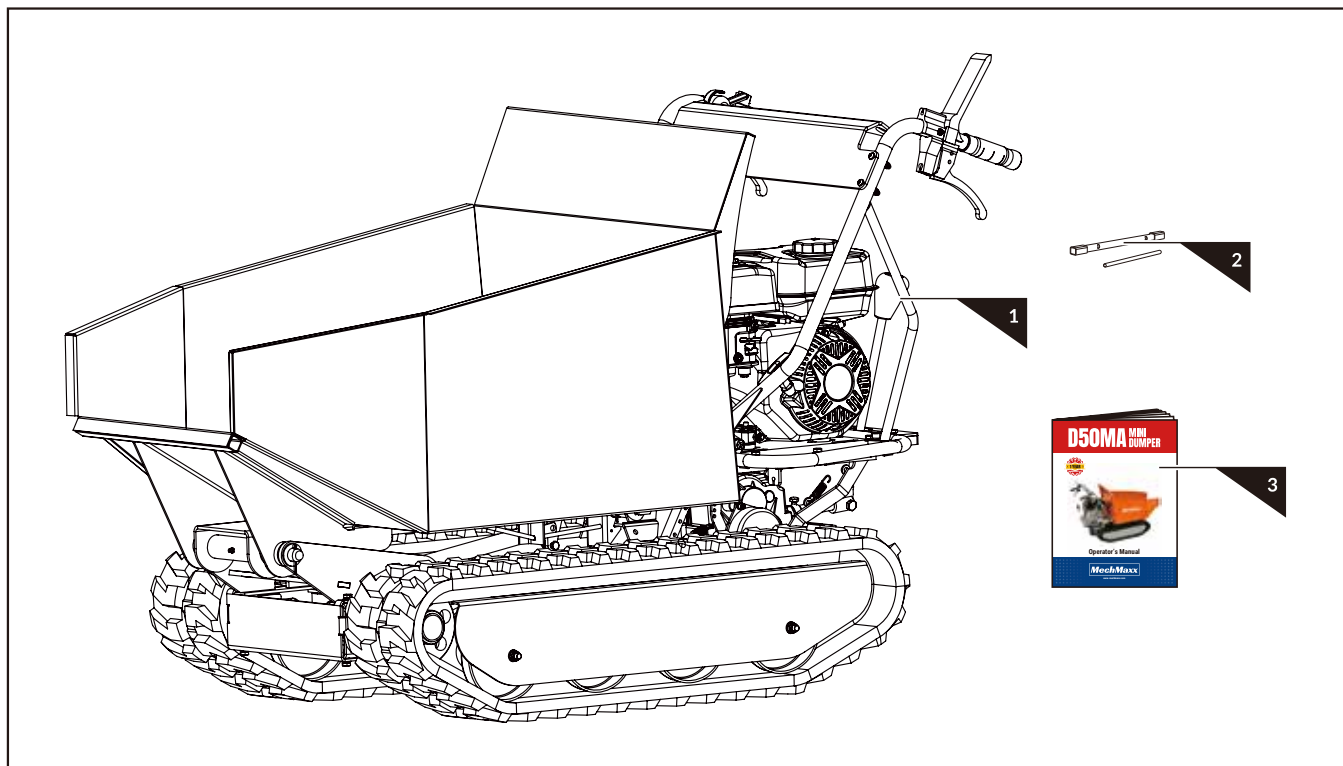

1. Machine

2. Operator's Manual & Engine Manual

3. Tools for Spark Plug Assembly

KNOW YOUR MACHINE

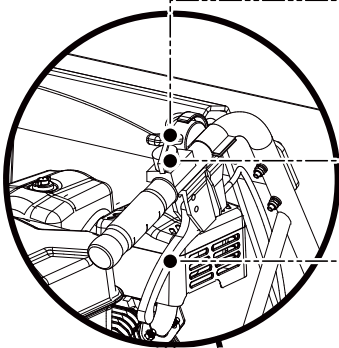

Throttle Control

Engine Switch

Right Steering Lever

Clutch Control Lever

Left Steering Lever

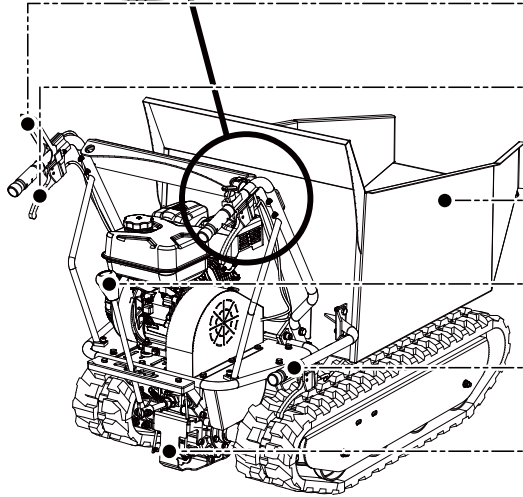

Dump Box

Gear Selection Lever

Tipping Handle

Gearbox

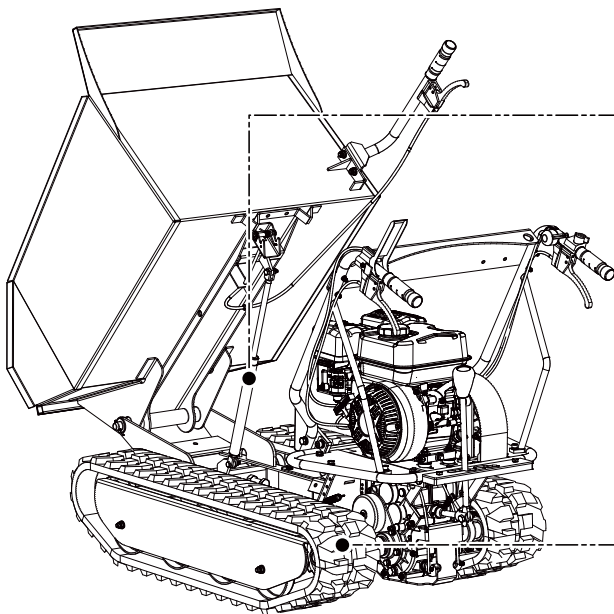

Gas Spring Assistance

Track

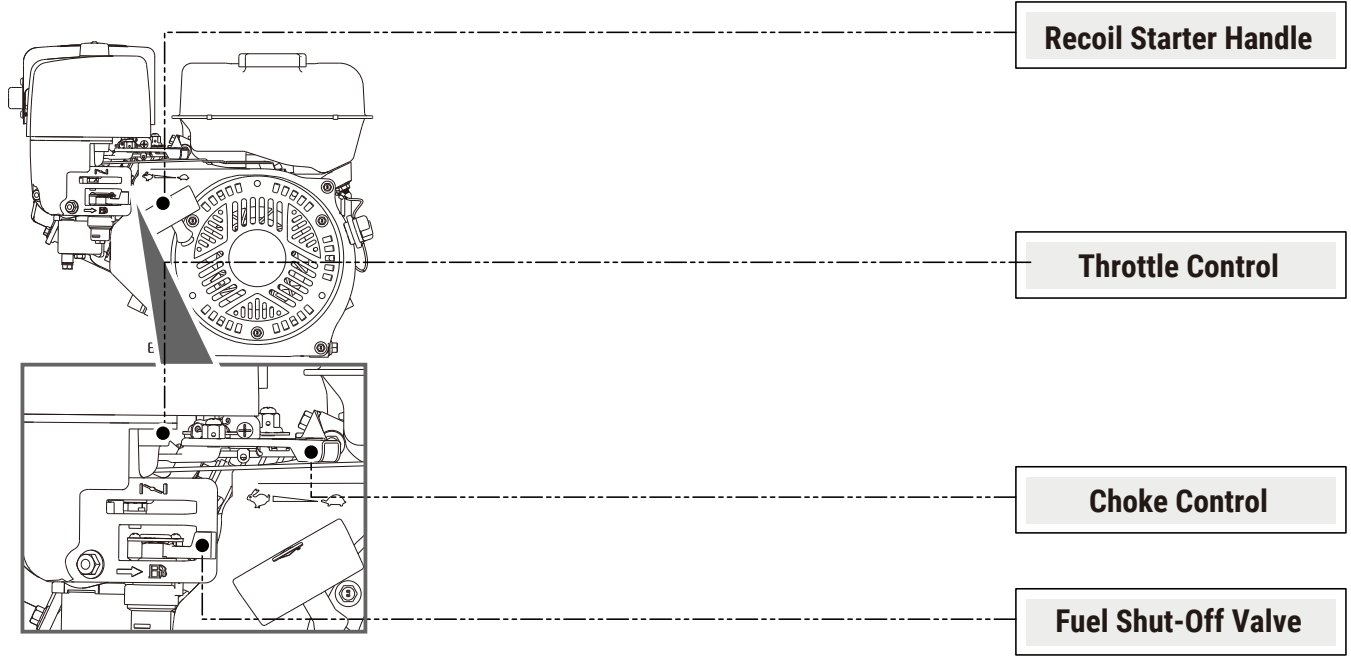

GEAR SELECTION LEVER

The gear selection lever has 4 positions: 3 forward speeds and 1 reverse. To change speeds, move the speed shift lever to the desired position. The lever locks in a notch at each speed selection.





Always release the clutch control lever before changing speeds. Failure to do so will result in damage to the power trackbarrow.

Slower speeds are for heavier loads, while faster speeds are for transporting light loads or an empty hopper. It is recommended that you use a slower speed until you are familiar with the operation of the power trackbarrow.

If the engine slows down under a load or the tracks slip, shift the machine into a lower gear.

If the front of the machine rides up, shift the machine into a lower gear. If the front continues to ride up, lift up on the handles.

LEFT/RIGHT STEERING LEVER

Operate the lever to turn left/right.



Operate the steering levers only at a reduced speed.

GAS SPRING ASSISTANCE

The gas spring assistance provides support when lifting and lowering the hopper.

ENGINE ON/OFF SWITCH

The engine switch has two positions. OFF engine will not start or run. ON - engine will start and run.

ENGINE ON/OFF SWITCH

The recoil starter handle is used to start the engine.

FUEL SHUT-OFF VALVE

The fuel shut-off has two positions:

CLOSED () - Use this position to service, transport, or to store the unit.

OPEN () - Use this position to run the unit.

THROTTLE CONTROL

The throttle control regulates the speed of the engine, and moves between FAST  SLOW  and STOP positions.

The throttle control will shut off the engine when it is moved to the STOP position.

CHOKE CONTROL

The choke control is used to choke the carburetor and assist in starting the engine. The choke control slides between the CHOKE CLOSED|↘|and CHOKE OPEN|↑|positions.



Never use choke to stop engine.

CLUTCH CONTROL LEVER

Squeeze the control lever, clutch engaged. Release the lever, clutch disengaged.

OPERATION

ADD OIL TO ENGINE



No oil in the engine originally, but a bottle of engine oil is in scope of delivery. Don't start the engine before adding oil.

1. Make sure the power trackbarrow is on a flat, level surface.
2. Remove the oil fill cap/dipstick to add oil.

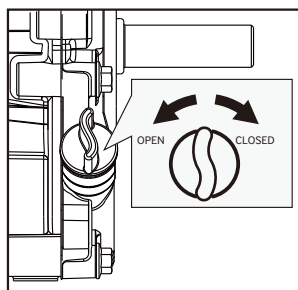

3. Using a funnel, add oil up to the FULL mark on the dipstick. (See engine manual for oil capacity, oil recommendation, and location of fill cap.)



DO NOT OVERFILL. Check engine oil level daily and add as needed.

ADD GASOLINE TO ENGINE



Gasoline is highly flammable and explosive. You can be burned or seriously injured when handling fuel. Use extreme care when handling gasoline.



Fill the fuel tank outdoors, never indoors. Gasoline vapors can ignite if they collect inside an enclosure. Explosion can result.

1. The engine must be off and allowed to cool at least two minutes before adding fuel.
2. Remove the fuel filler cap and fill the tank. (See engine manual for fuel capacity, fuel recommendation, and location of fuel cap.)

IMPORTANT: DO NOT OVERFILL!

This equipment and/or its engine may include evaporative emissions control system components, required to meet EPA and/or CARB regulations, that will only function properly when the fuel tank has been filled to the recommended level. Overfilling may cause permanent damage to evaporative emissions control system components. Filling to the recommended level ensures a vapor gap required to allow for fuel expansion. Pay close attention while filling the fuel tank to ensure that the recommended fuel level inside the tank is not exceeded. Use a portable gasoline container with an appropriately sized dispensing spout when filling the tank. Do not use a funnel or other device that obstructs the view of the tank filling process.



3. Reinstall the fuel cap and tighten. Always clean up spilled fuel.

STARTING ENGINE

1. Move the engine switch to the ON position.

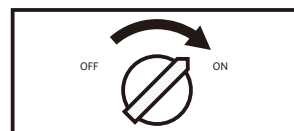

2. Open the fuel shut-off valve.

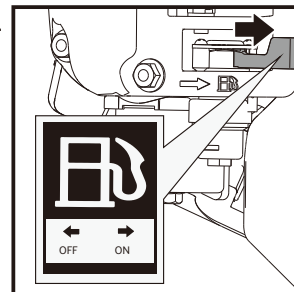

3. Move the choke lever to the CLOSED position.

» If the engine is hot, closing the choke is not necessary.

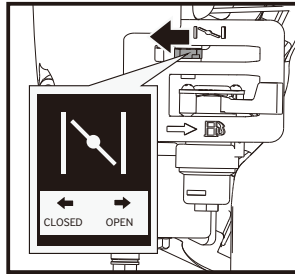

4. Move the throttle lever slightly to the FAST speed.

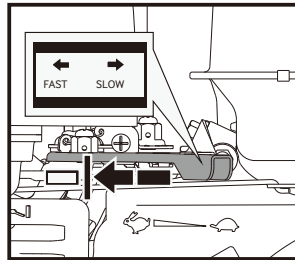

5. Pull the recoil starter until engine compression has become difficult to pull. Let the recoil return to the home position, then pull quickly to start the engine. Repeat steps as needed. Fully open the choke and set the throttle to the FAST position, before operating the unit.



Rapid retraction of the starter cord (kick-back) will pull your hand and arm toward the engine faster than you can let go. Broken bones, fractures, bruises, or sprains could result.

OPERATING

After the engine warms up, move the throttle lever to accelerate engine speed.

Engage the required gear and slowly squeeze the clutch control lever. If the gear does not engage immediately, slowly release the clutch lever and try again. In this way the power trackbarrow will start moving.

The power trackbarrow has the steering levers on the handlebars, which makes steering very easy. To turn right or left, simply pull the corresponding right or left steering lever.

The sensitivity of the steering increases in proportion to the speed of the machine and the load. With an empty machine, a light pressure on the lever is all that is needed to turn. When the machine is fully loaded, more pressure is required.

The power trackbarrow has a maximum capacity of 660 LBS. However, it is advisable to assess the load and adjust it according to the ground on which the machine will be used.

It is therefore advisable to cover such stretches using low gear and taking extra care. In such situations, the machine should be kept in low gear for the whole stretch. Avoid sharp turns and frequent changes of direction while driving on rough, hard terrains full of sharp, uneven points with a high degree of friction.

Even though the unit has rubber tracks, remember to be careful when working in adverse weather conditions (ice, heavy rain and snow) or on types of ground that could make the power trackbarrow unstable.

Please note that as this is a tracked vehicle, it is subject to a considerable pitching movement when passing over bumps, holes and steps.

When the clutch control lever is released, the machine will stop and brake automatically.

If the machine is stopped on a steep slope, a wedge should be placed against one of the tracks.

IDLE SPEED

Set the throttle control lever to the SLOW position to reduce stress on the engine when work is not being performed. Lowering the engine speed will help extend the life of the engine, as well as conserve fuel and reduce noise level.

STOP ENGINE

To stop the engine in an emergency, simply turn the engine switch to the OFF position. Under normal conditions, use the following procedure:

1. Move the throttle lever to the SLOW (☂) position.
2. Let the engine idle for one or two minutes.
3. Turn the engine switch to the OFF position.
4. Turn the fuel valve lever to the OFF (⊘) position.



Sudden stopping at a high speed under a heavy load is not recommended. Engine damage may result.



Do not move the choke control to CLOSE to stop the engine. Backfire or engine damage may occur.

MAINTENANCE

Maintaining your mini tracked dumper will ensure long life to the machine and its components.

PREVENTIVE MAINTENANCE

1. Turn off the engine and disengage all command levers. The engine must be cool.
2. Keep the engine's throttle lever in its SLOW position and remove the spark plug wire from the spark plug and secure.
3. Inspect the general condition of the power trackbarrow. Check for loose screws, misalignment or binding of moving parts, cracked or broken parts, and any other condition that may affect its safe operation.
4. Use a soft brush, vacuum or compressed air to remove all contaminants from the machine. Then use high quality light oil to lubricate all moving parts.
5. Check the spark plug wire regularly for signs of wear, and replace when needed.



Never use a "pressure washer" to clean your unit. Water can penetrate tight areas of the machine and its transmission case and cause damage to spindles, gears, bearings, or the engine. The use of pressure washers will result in shortened life and reduce serviceability.

ADJUSTING CLUTCH

When the clutch begins to show wear, the handle reach will become wider, making it more difficult to reach. Follow these steps to return the clutch lever back to its original position.

1. Loosen the jam nut by turning it counter clockwise with 10mm wrench.
2. Tighten or loosen the cable by turning the cable adjustment nut clockwise or counter clockwise with 10mm wrench until you have reached your required tightness.
3. Once tightness is set, return the jam nut against the handle to hold the cable in place.

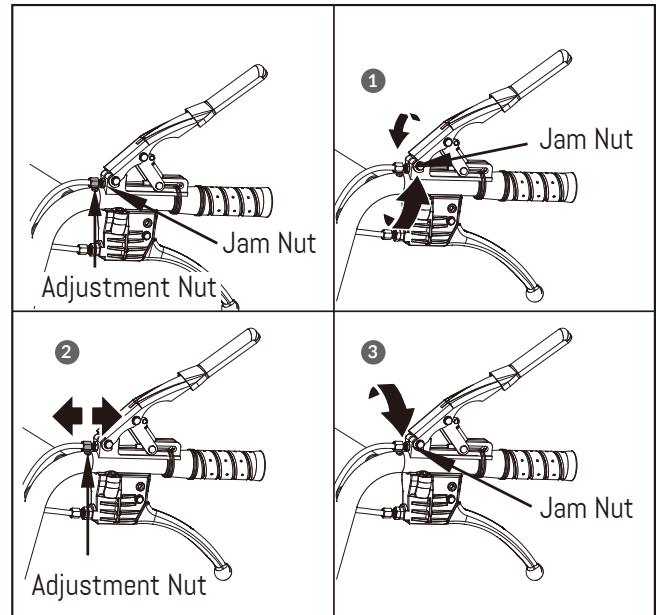

ADJUSTING STEERING

If steering becomes difficult to engage follow these steps to adjust the cable tension.

1. Loosen the jam nut by turning it counter clockwise with 10mm wrench.
2. Tighten or loosen the cable by turning the cable adjustment nut clockwise or counter clockwise with 10mm wrench until you have reached your required tightness.
3. Once tightness is set, return the jam nut against the handle to hold the cable in place.

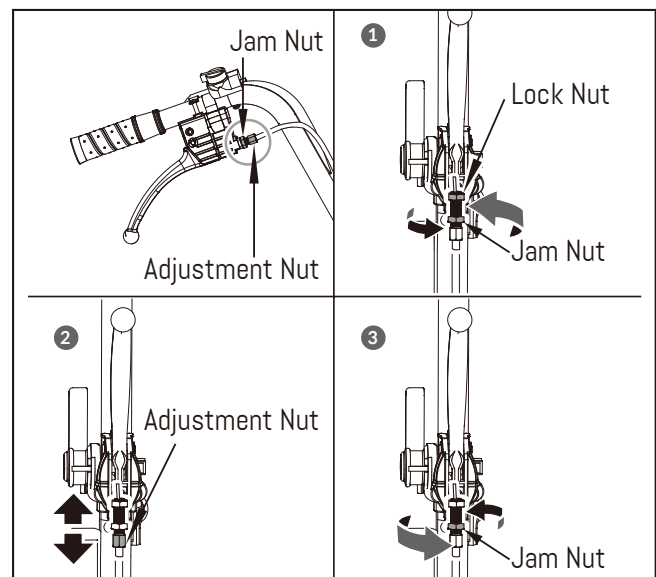

If the above adjustment does not create enough cable tension, follow the steps below:

1. Loosen the jam nut by turning it counter clockwise with 12mm wrench.
2. Tighten or loosen the cable by turning the cable adjustment nut clockwise or counter clockwise with 10mm wrench until you have reached your required tightness.
3. Once tightness is set, return the jam nut against the handle to hold the cable in place.

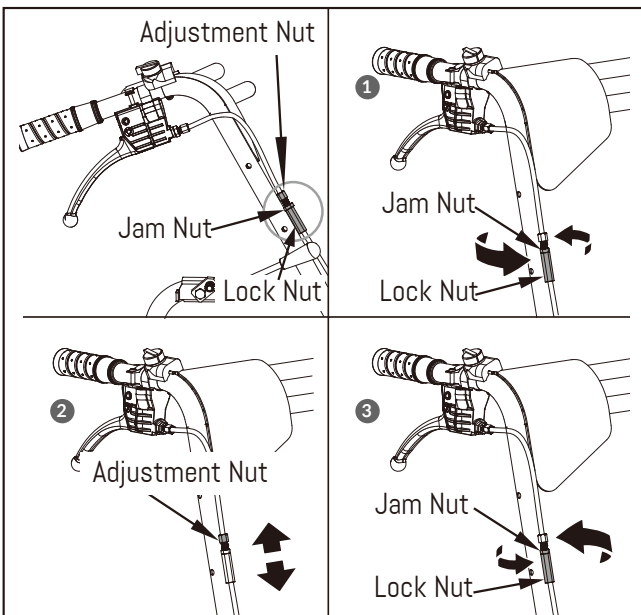

REPLACING DRIVE BELT

Remove the belt cover for gearbox pulley.

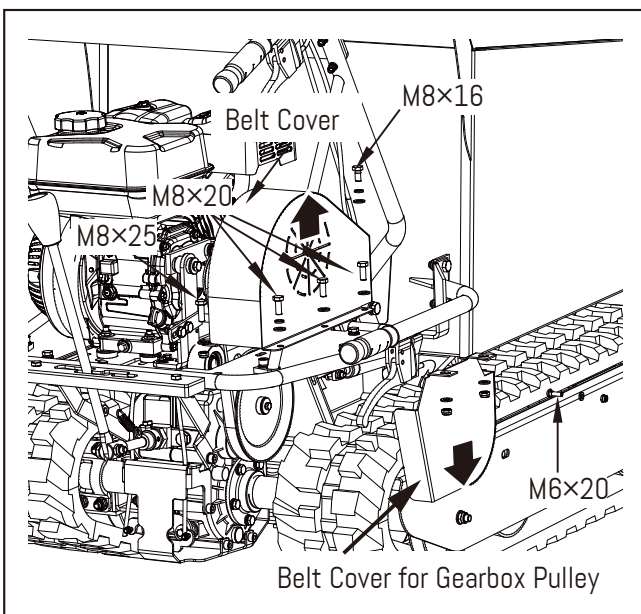

Loosen the two bolts M8X25 and one bolt M8x30 that fix the two belt blockers, no need to remove them. Pull out the belt.

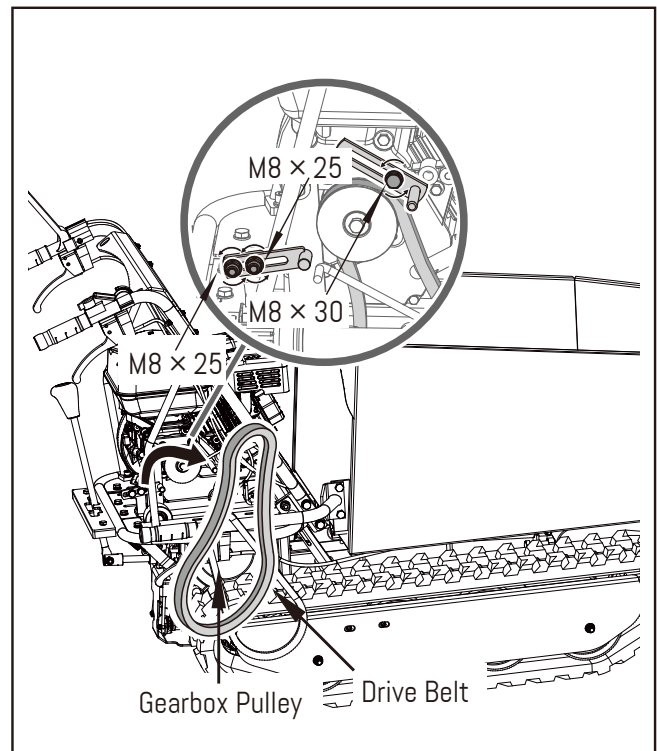

 **You may need to loosen the belt guide bracket and slide back before removing belt.**

GENERAL LUBRICATION

Lightly lubricate all moving parts of the machine at end of the season or every 25 operating hours.

GEARBOX LUBRICATION

The gearbox is pre-lubricated and sealed at the factory. Unless there is evidence of leakage or service has been performed on the gearbox, no additional lubricate should be required until 50 hours use.

After first 50 hours use, change all the gear oil. Capacity is 1.5L.

For future use, check the oil level after every 50 hours of use. If you remove the oil level plug and no oil flows out, please add oil and then screw the oil level plug.

Gear oil GL-5 or GL-6, SAE80W-90 is recommended. Do not use synthetic oil.

When replacing gear oil, the engine must be stopped and still warm. Unscrew the filter cap and the drain plug. When oil is drained, replace the drain plug, fill up with fresh oil, and then replace the filter cap.

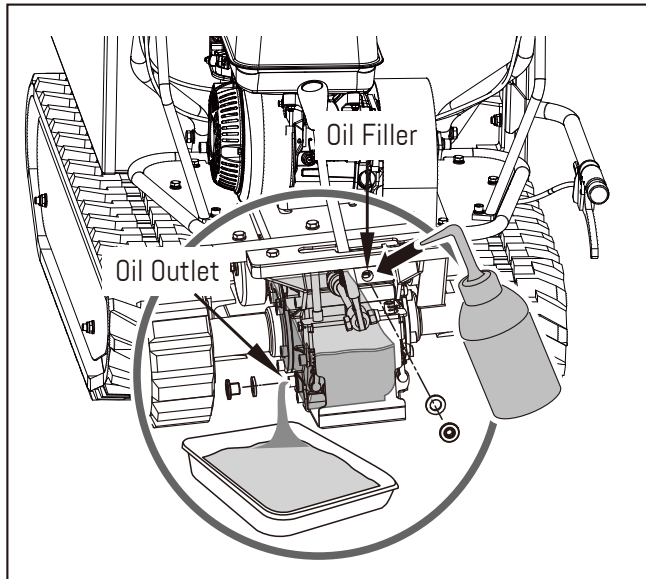

TIGHTENING TRACKS

With use, tracks tend to loosen. When operating with loose tracks, they tend to slip over the driving wheel causing it to jump its housing, thus damaging wear to the housing.

To check track tightness, proceed as follows.

1. Set the machine on a flat surface with compact ground, or on asphalt or pavement.
2. Lift the machine and set it on blocks or supports rated for the weight of the machine so that the tracks are approximately 4" off the ground.
3. Measure the track midline vs. the horizontal line. The reading must not be more than 10cm-15cm

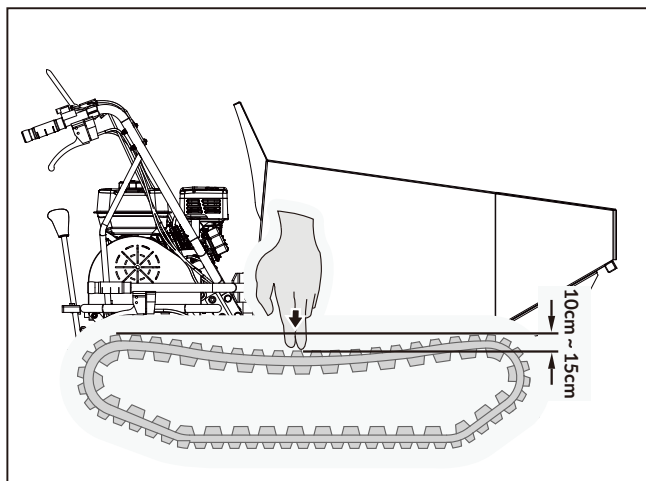

If the distance is greater, proceed as follows.

1. Use the tipping handle to tip the hopper and set it on blocks or supports rated for the weight of the box.
2. Loosen lock nut A.
3. Tighten bolt B until the correct tightness is restored.
4. Secure bolt B by tightening lock nut A thoroughly.
5. Return the hopper to its original position.

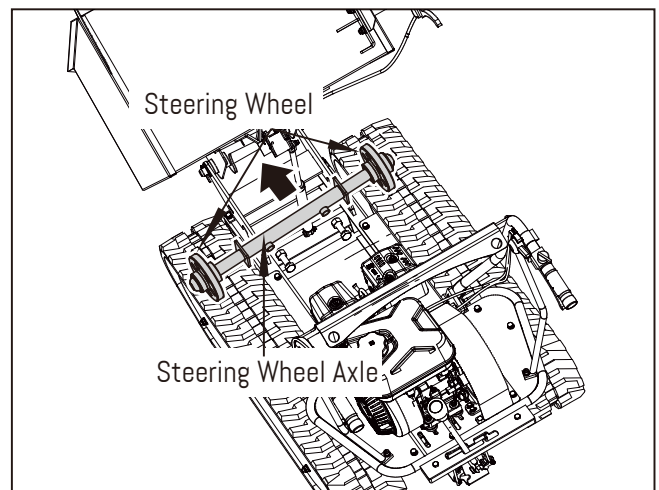
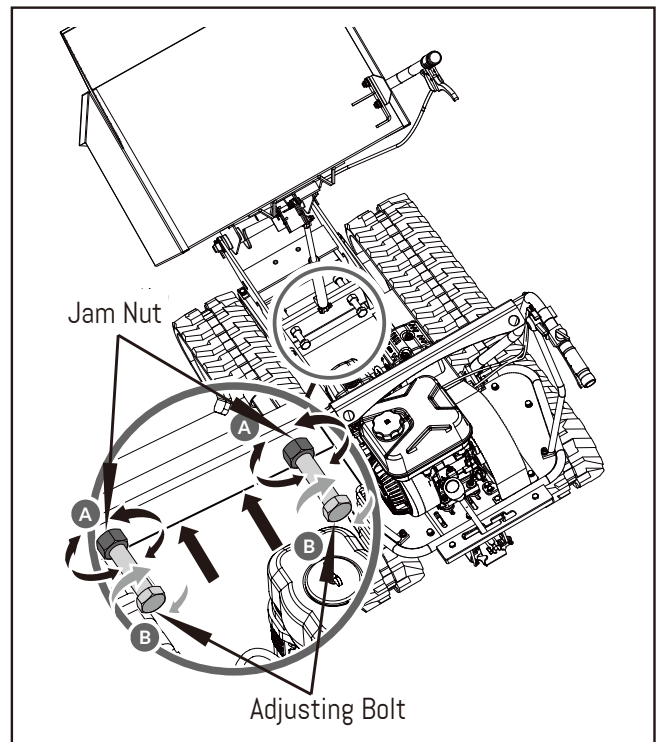

Do not over-tighten your track. The adjustment of the track and the brakes are linked. The braking power will lessen the more the track is tightened.



If the adjustment bolt has no more adjustment left, the tracks may have to be replaced.

REPLACING TRACKS

Check the condition of the tracks periodically. If any track is cracked or frayed, it should be replaced as soon as convenient.

1. Lift up the hopper and insert a support rod for safety purposes.
2. Lift the machine and set it on blocks or supports rated for the weight of the machine so that the tracks are approximately 10 cm off the ground.

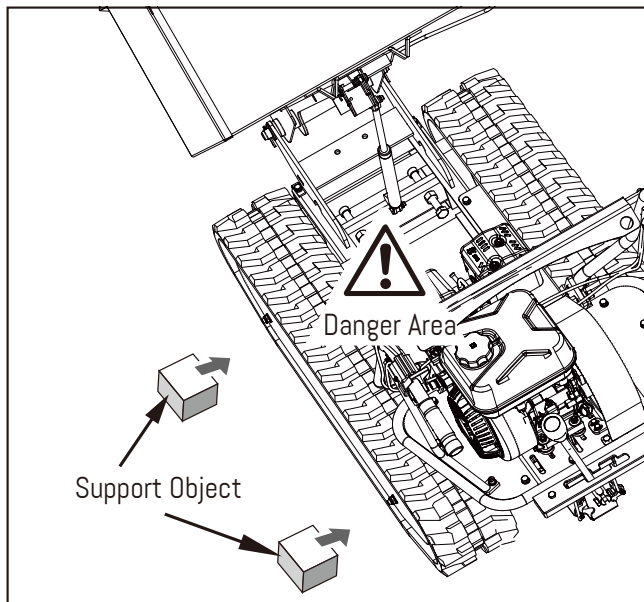

3. Remove the three M8×16 bolts and washers that fix the track protection guard.

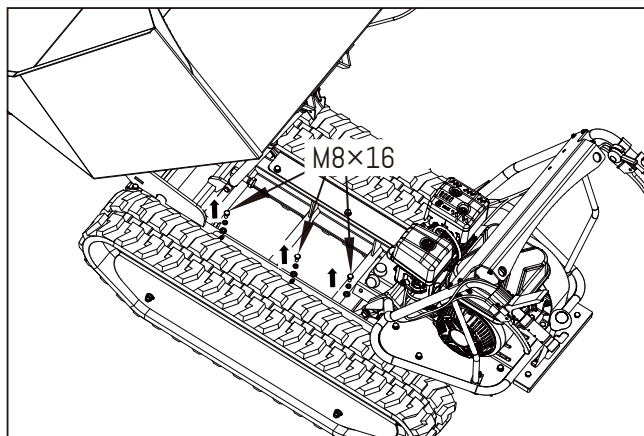

4. Remove the two M10 nuts and washers from the side of track protection guard and take off the track protection guard.

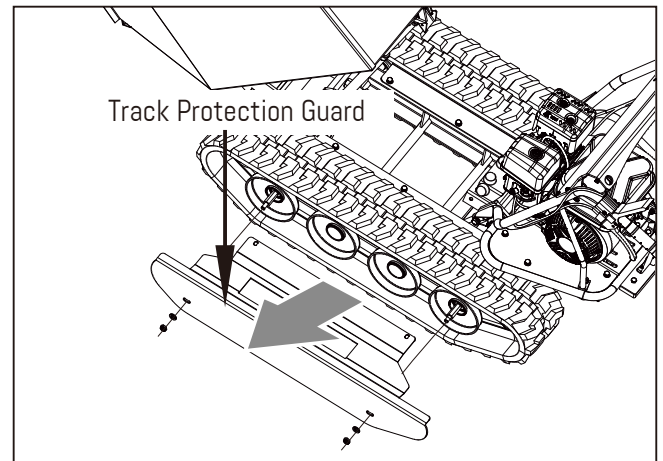

5. Loosen the adjusting bolts and pull the steering wheel axle toward the engine, then track will be loosen.

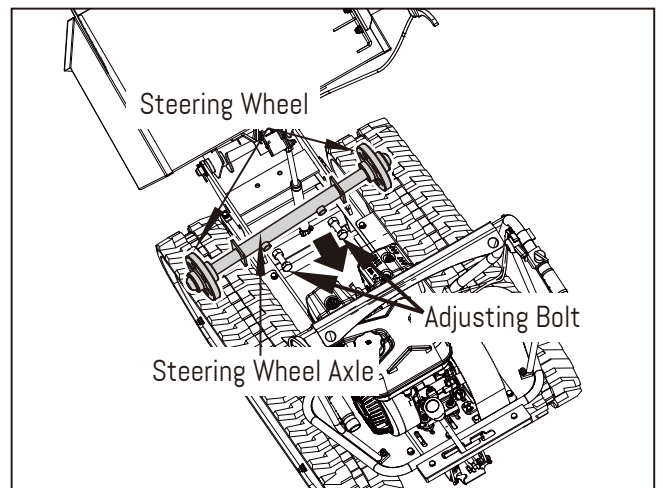

6. Remove the M10×60 bolt, washers and nut from the driving wheel.
7. Pull out the whole track with driving wheel.

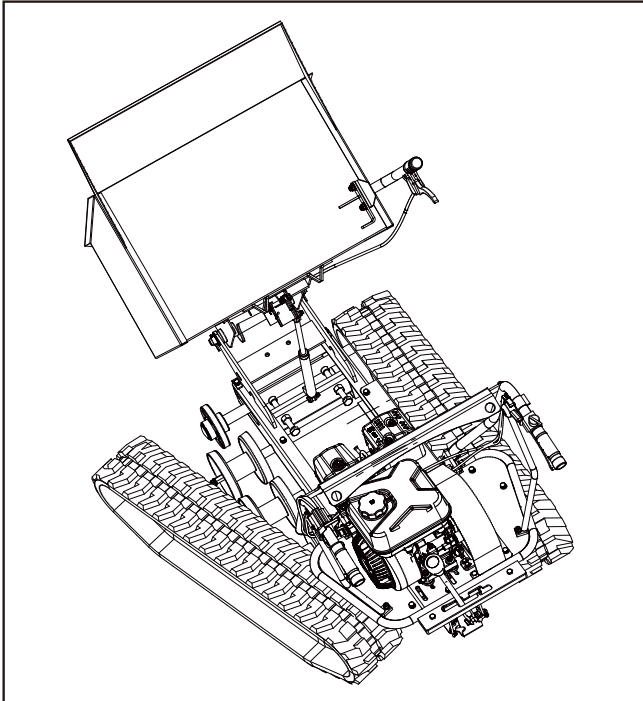

When removing or installing the tracks, be careful not to get your fingers caught between the track and pulley.

ENGINE MAINTENANCE

Refer to the Engine Manual included in your unit for the information on engine maintenance. Your engine manual provides detailed information and a maintenance schedule for performing the tasks.

STORAGE

If the mini tracked dumper will not be used for a period longer than 30 days, follow the steps below to prepare your unit for storage.

1. Drain the fuel tank completely. Stored fuel containing ethanol or MTBE can start to go stale in 30 days. Stale fuel has high gum content and can clog the carburetor and restrict fuel flow.
2. Start the engine and allow it to run until it stops. This ensures no fuel is left in the carburetor. Run the engine until it stops. This helps prevent gum deposits from forming inside the carburetor and possible engine damage.
3. While the engine is still warm, drain the oil from the engine. Refill with fresh oil of the grade recommended in the Engine Manual.
4. Use clean cloths to clean off the outside of the machine and to keep the air vents free of obstructions.



Do not use strong detergents or petroleum based cleaners when cleaning plastic parts. Chemicals can damage plastics.

5. Inspect for any loose or damaged parts. Repair or replace damaged parts and tighten loose screws, nuts or bolts.
6. Store your unit on flat ground in a clean, dry building that has good ventilation.



Do not store the machine with fuel in a non-ventilated area where fuel fumes may reach flame, sparks, pilot lights or any ignition sources.

TROUBLESHOOTING

Problem	Cause	Remedy
Engine fails to start.	<ol style="list-style-type: none">1. Spark plug wire disconnected.2. Out of fuel or stale fuel.3. Choke not in open position.4. Blocked fuel line.5. Fouled spark plug.6. Engine flooding.	<ol style="list-style-type: none">1. Attach spark plug wire securely to spark plug.2. Fill with clean, fresh gasoline.3. Throttle must be positioned at choke for a cold start.4. Clean the fuel line.5. Clean, adjust gap, or replace.6. Wait a few minutes to restart, but do not prime.
Engine runs erratically.	<ol style="list-style-type: none">1. Spark plug wire loose.2. Unit running on CHOKE.3. Blocked fuel line or stale fuel.4. Vent plugged.5. Water or dirt in fuel system.6. Dirty air cleaner.7. Improper carburetor adjustment.	<ol style="list-style-type: none">1. Connect and tighten spark plug wire.2. Move choke lever to OFF.3. Clean fuel line. Fill tank with clean, fresh gasoline.4. Clear vent.5. Drain fuel tank. Refill with fresh fuel.6. Clean or replace air cleaner.7. Refer to Engine Manual.
Engine over heats.	<ol style="list-style-type: none">1. Engine oil level low.2. Dirty air cleaner.3. Air flow restricted.4. Carburetor not adjusted properly	<ol style="list-style-type: none">1. Fill crankcase with proper oil.2. Clean air cleaner.3. Remove housing and clean.4. Refer to Engine Manual.
Machine does not move while engine is running	<ol style="list-style-type: none">1. Gear is not properly selected.2. Drive belt not tight enough.	<ol style="list-style-type: none">1. Ensure gear lever is not in between two different gears.2. Tighten drive belt.
One of the two tracks is blocked.	Foreign bodies have worked their way between the track and the frame.	Remove the foreign body.

MechMaxx

info@mechmaxx.com