

MBW

TROWELS



MBW POWER TROWEL



[F36 | F46]

[F24]

MBW

BUILDING A BETTER JOBSITE EXPERIENCE

MBW.COM



TROWELS

WALK BEHIND POWER TROWELS



To function properly, power trowels must maintain a precise perpendicular relationship between the gearbox's output shaft and blade arms. Once that relationship is compromised, the trowel will vibrate and/or wobble. MBW has gone to great lengths to maintain this critical relationship.

MBW WALK-BEHIND POWER TROWELS feature the industry's heaviest bearings, output shafts, gears, spiders and blade arms. Comparison of these critical MBW components to those of any competitor answers the question as to why MBW trowels run so well for so long.

GEAR BOX

Designed for our heaviest trowel, the MBW gear box is overbuilt and preserves component commonality throughout the range. Housing and covers made of cast aluminum alloy feature reinforced construction. Cooling fins insure rapid heat dissipation for extended bearing and lubricant life. MBW's one piece, case hardened wormshaft is the most accurate in the industry. Ground bearing journals insure exact bearing alignment and maximum bearing life. All MBW bearings are able to accept load spikes and provide long life under rigorous use. MBW's bronze wormgear conforms to exacting specifications and features extra heavy-duty hub and flange construction. High quality seals and o-rings provide resistance to leakage and enhances life of the industry's most rugged gear box.

Precision alignment, serviceability, and resistance to application induced bending or wear, characterize MBW's spider assembly. An entire battery of numerically controlled metal working machinery and in-process inspection procedures allow no compromise on tolerances. Other alignment considerations include Teflon lined, steel arm/bore inserts, and arms which are precisely milled to provide the most accurate blade-to-arm alignment. All components subject to high levels of stress are overbuilt: heavier trowel arms (both hex and machined sections), tilt arm, spider castings, and yoke plates. The pressure plate features a deep collar for added support on spider. Yoke plate is designed for widest dispersal of tilting pressures and is machined to accept a greasable thrust bearing.



The EZ Pitch™ handle employs a constant force gas spring to allow for low effort and rapid adjustment of blade pitch. Can be retrofitted to older MBW trowels as a complete assembly.



Patented Low Vibration handle to reduce operator fatigue. Can be retrofitted to older MBW trowels as a complete assembly.



Tool free height adjustable operator handle



Power Pitch handle option includes LED lights and trowel blade adjustment with two waterproof switches

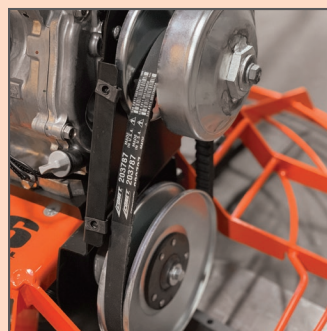

Optional high torque clutch available on both the 36" and 46" trowel.

F24 EDGER TROWEL



The **F24 EDGER TROWEL** is the ultimate finishing tool for professional results in confined spaces. Designed for lightweight maneuverability, this specialty power trowel excels where others fall short, even when confined areas or weight restrictions leave other machines standing idle. Perfect for edging in the tightest spaces, the F24 Edger Trowel is always ready when needed.

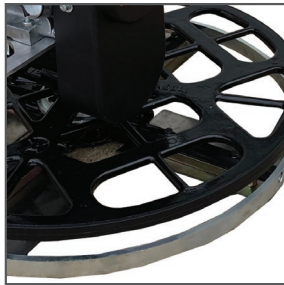

ROTATING GUARD RING



FOLD DOWN HANDLE

MODEL	F24
Engine Options	Honda GX160 (135 lbs/61 kg) 3 HP Motor Single Phase 220V (126 lb/57 kg)
Ring Diameter	24 in (61 cm)
Trowel Speed	70-125 rpm

() Metric Measurements



MBW Inc.
250 Hartford Road • P.O. Box 440
Slinger, Wisconsin • 53086-0440 • USA
Ph: 800-678-5237 or 262-644-5234 • Fax: 262-644-5169
E-mail: mbw@mbw.com • Website: www.mbw.com

MBW Europe Ltd.
Units 2 & 3 Cochrane Street • Bolton BL3 6BN • England UK
Ph: 44 (0) 1204 387784 • Fax: 44 (0) 1204 387797
E-mail: mbwuk@mbw.com or mbweurope@mbw.com
Europe Website: www.mbweurope.com



AUTHORIZED DISTRIBUTOR

L16480 3/25
Copyright ©
MBW Incorporated
All Rights Reserved

F36 & F46 WALK-BEHIND TROWELS



Catering to the needs of operators, the MBW trowel stands out with its focus on comfort, safety, and longevity. Our trowel is thoughtfully designed with adjustable handles, ensuring a tailor-made fit for every operator, allowing them to work in absolute comfort.

All handle materials are heavy gauge and do not require gusseting at critical fastening points. Each MBW trowel is balanced with regard to engine location for excellent performance and reduced operator fatigue.

MBW's heavier handle and stronger guard ring add up to extra safety. Our safety switch is fully enclosed and constructed of durable materials with wire and cables housed at their most vulnerable positions. Basic operating and safety instructions are prominently displayed.

Solid throttle wire is housed in a low friction Teflon-lined casing for smooth operation and low maintenance.

US Patents

Both models available with either a Standard, EZ Pitch, Power Pitch or Low Vibration handle.

MODEL	F36	F46
Engine Options Operating Weight	Honda GX160 183 lbs (83 kg)	Honda GX270 246 lbs (112 kg)
	Honda GX270 209 lbs (95 kg)	Honda GX390 260 lbs (118 kg)
	Honda GX270 High Torque 216 lbs (98 kg)	Honda GX390 High Torque 267 lbs (121 kg)
Ring Diameter	37.5 in (95 cm)	47.6 in (121 cm)
Blade Sweep Dia.	35.5 in (90 cm)	46 in (117 cm)
Trowel Speed	70-135 rpm 35-180 rpm High Torque	70-135 rpm 35-180 rpm High Torque
Low Vibration Handle Height	35.8" Min - 43.3" Max	
Noise Level	85-105 dBA	

() Metric Measurements

CAST ALUMINUM ALLOY HOUSING

features reinforced construction and cooling fins for rapid dissipation of heat

VERTICAL SHAFT ASSEMBLY

has heavier flange & hubs for greater shaft support. Heavy duty high load capacity bearings add to gear box longevity

WORM SHAFT ASSEMBLY

is precision machined from solid stock. Bearing journals are precision ground for proper fit and preservation of internal bearing tolerances. 1230 lbs. - radial load capacity

HEX TO BLADE MATING SURFACE

is precision milled for near perfect blade alignment

TEFLON LINED STEEL BORE INSERTS

that will not pound out causing alignment problems

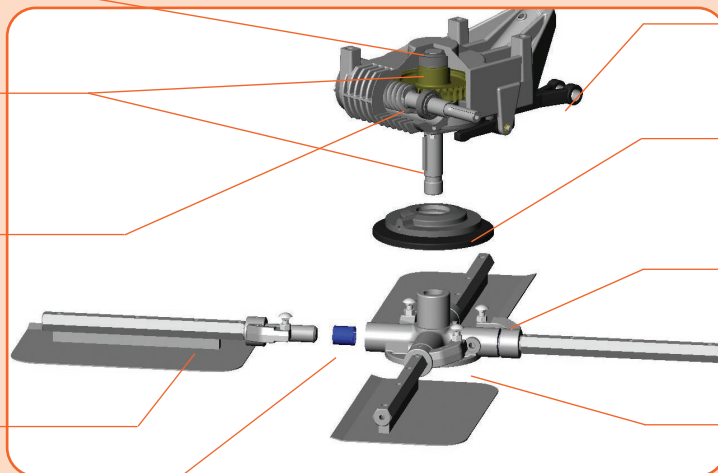

HEAVY CAST ENGAGEMENT YOKE

with wider and longer construction to increase life and control of blade adjustment cable

PRESSURE PLATE ASSEMBLY

utilizes greasable thrust bearings to provide little or no RPM variation

TILT ARM ASSEMBLY

utilizes the industry's heaviest material both in hex stock and larger diameter machined ends

SPIDER ASSEMBLY

is 15% heavier than competitive models with thicker walls around all bores. Industrial grade 45 degree grease fittings and hardware throughout machine ensures long life