

OPERATOR'S SAFETY AND SERVICE MANUAL



MM90

This manual covers the following serial numbers
and higher for each model listed:

MM90 7051510



MORTAR & PLASTER MIXER

MBW, Inc.
250 Hartford Rd • PO Box 440
Slinger, WI 53086-0440
Phone: (262) 644-5234
Fax: (262) 644-5169
Email: mbw@mbw.com
Website: www.mbw.com

MBW Europe Ltd.
Units 2 & 3 Cochrane Street
Bolton BL3 6BN, England
Phone: + 44 (0) 01204 387784
Fax: + 44 (0) 01204 387797
Email: saleseurope@mbw.com
Website: www.mbw europe.com

L16746. 07.24.AC
©MBW, Inc. 2005
Printed in the USA

TABLE OF CONTENTS

SAFETY INFORMATION	1	Lubrication	8
Introduction	1	Belt Guides	9
Safety Precautions	1	Greasing Wheel Bearings	9
SPECIFICATIONS	5	SERVICE	10
OPERATION	6	Torque Chart	10
Introduction	6	Engine Shroud Removal	10
Before Starting & Operating	6	Engine Shroud Installation	10
Wiring Electric Motor	6	Drum Removal	10
Starting Gas Engine	6	Drum Installation	10
Starting Electric Motor	6	Drum Bearing & Seals Replacement	11
Operating	6	Engine Removal	11
Stopping Gas Engine	6	Engine Installation	11
Stopping Electric Motor	7	Parts Replacement Cycles and Tolerances	12
Towing	7	REPLACEMENT PARTS	13
MAINTENANCE	8	Drum Assembly	14
Maintenance Schedule	8	Drivetrain Assembly	16
Engine Maintenance	8	Idler Assembly	18
Engine Speed	8	Frame & Axle Assembly	20
Cleaning	8	Paddle Assembly	22
		WARRANTY	24



WARNING



CALIFORNIA PROPOSITION 65 WARNING

Engine exhaust and some of its constituents and dust produced during the use of this product contain chemicals known in the state of California to cause cancer, birth defects, and other reproductive harm.

For more information go to **www.P65Warnings.ca.gov**

SAFETY INFORMATION

Introduction



This Safety Alert Symbol is used to call attention to items or operations which may be dangerous to those operating or working with this equipment.

The symbol can be found throughout this manual and on the unit. Please read these warnings and cautions, along with all decals, carefully before attempting to operate the unit. Make sure every individual who operates or works with this equipment is familiar with all safety precautions.

WARNING

GENERAL WARNING. Indicates information important to the proper operation of the equipment. Failure to observe may result in damage to the equipment and/or severe bodily injury or death.

CAUTION

GENERAL CAUTION. Indicates information important to the proper operation of the equipment. Failure to observe may result in damage to the equipment.

Safety Precautions



LETHAL EXHAUST GAS: An internal combustion engine discharges carbon monoxide, a poisonous, odorless, invisible gas. Death or serious illness may result if inhaled. Operate only in a properly ventilated area. **NEVER OPERATE IN A CONFINED AREA!**



DANGEROUS FUELS: Use extreme caution when storing, handling and using fuels as they are highly volatile and explosive in vapor state. Do not add fuel while engine is running. Stop and cool the engine before adding fuel. **DO NOT SMOKE!**



SAFETY GUARDS: It is the owner's responsibility to ensure that all guards and shields are in place and in working order.



IGNITION SYSTEMS: Breakerless, magneto, and battery ignition systems can cause severe electrical shocks. Avoid contacting these units or their wiring.



SAFE DRESS: Do not wear loose clothing, rings, wristwatches, etc. near machinery.



NOISE PROTECTION: Wear OSHA specified hearing protection devices.



EYE PROTECTION: Wear OSHA specified eye shields, safety glasses, and sweat bands.



FOOT PROTECTION: Wear OSHA specified steel-tipped safety shoes.



HEAD PROTECTION: Wear OSHA specified safety helmets.

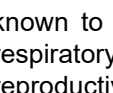

OPERATOR: Keep children and bystanders off and away from the equipment.

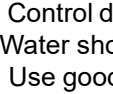

DUST PROTECTION: Machining, crushing or handling of stone, concrete, masonry, metal and other materials may generate dust, mist and fumes containing chemicals such as silica

known to cause serious or fatal injury or illness such as respiratory disease, silicosis, cancer, birth defects, or other reproductive harm.

- Control dust, mist and fumes at the source where possible. Water should be used to control dust whenever feasible.
- Use good work practices and follow the recommendations of the manufacture, OSHA/NIOSH and other occupational trade associations.
- When hazards cannot be eliminated the operator and any bystanders should always wear a OSHA specified respirator for materials being handled.

REFERENCES: For details on safety rules and regulations in the United States, contact your local Occupational Safety and Health Administration (OSHA) office. Equipment operated in other countries must be operated and serviced in accordance and compliance with any and all safety requirements of that country. The publication of these safety precautions is done for your information. MBW does not by the publication of these precautions, imply or in any way represent that these are the sum of all dangers present near MBW equipment. If you are operating MBW equipment, it is your responsibility to insure that such operation is in full accordance with all applicable safety requirements and codes. All requirements of the United States Federal Occupational Safety and Health Administration Act must be met when operated in areas that are under the jurisdiction of that United States Department.

Safety Decals

Carefully read and follow all safety decals. Keep them in good condition. If decals become damaged, replace as required. If repainting the unit, replace all decals. Decals are available from authorized MBW distributors. Order the decal set listed on the following page.

CAUTION(PRECAUCIÓN)

Improper towing can lead to damage or injury.

- Before Towing:
1. Check running gear and tow bar.
 2. Lock drum in tow position.
 3. Check tow pin for proper installation and good condition.
 4. USE SAFETY CHAINS when towing.

MAXIMUM TOW SPEED: 50 mph
Un remolque incorrecto puede provocar daños materiales o lesiones.

- Antes del remolque:
1. Revise el funcionamiento de los engranajes y de la barra de remolque.
 2. Bloquee el tambor en la posición de remolque.
 3. Verifique que el pasador de remolque esté bien instalado y en buen estado.
 4. USE CADENAS DE SEGURIDAD al remolcar la máquina.
- MÁX. VELOCIDAD DE REMOLQUE: 80 KPH**

15072

15072

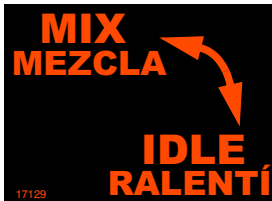

17129



21034 "MM90"

CAUTION (PRECAUCIÓN)#

- Read the operating instructions before operating this piece of equipment.
 Lea las Instrucciones Operativas antes de hacer funcionar esta parte del equipo.
- Keep unauthorized, inexperienced, untrained people away from this equipment.
 Mantenga a las personas no autorizadas y sin entrenamiento alejadas de este equipo.
- ROTATING AND MOVING PARTS!** Make sure all guards and safety devices are in place.
¡PIEZAS ROTATIVAS Y MOVILES! Asegúrese de que todas las guardas y dispositivos de seguridad estén colocados en sus lugares.
- DO NOT RUN** this machine in an enclosed area. The engine produces carbon monoxide, a **POISONOUS** gas.
NO HAGA FUNCIONAR esta máquina en una zona encerrada. El motor produce monóxido de carbono, un **GAS VENENOSO**.
- Avoid breathing dust produced while operating machine, wear OSHA specified dust mask/respirator.
 Evite respirar el polvo producido durante el funcionamiento de la máquina, use mascarilla contra el polvo y respirador especificada por OSHA.
- SHUT OFF** the engine before servicing, cleaning or adding fuel to engine or machine.

Failure to comply could result in serious bodily injury

El no cumplir con estas instrucciones puede producir como resultado lesiones corporales graves. (15070)

15070

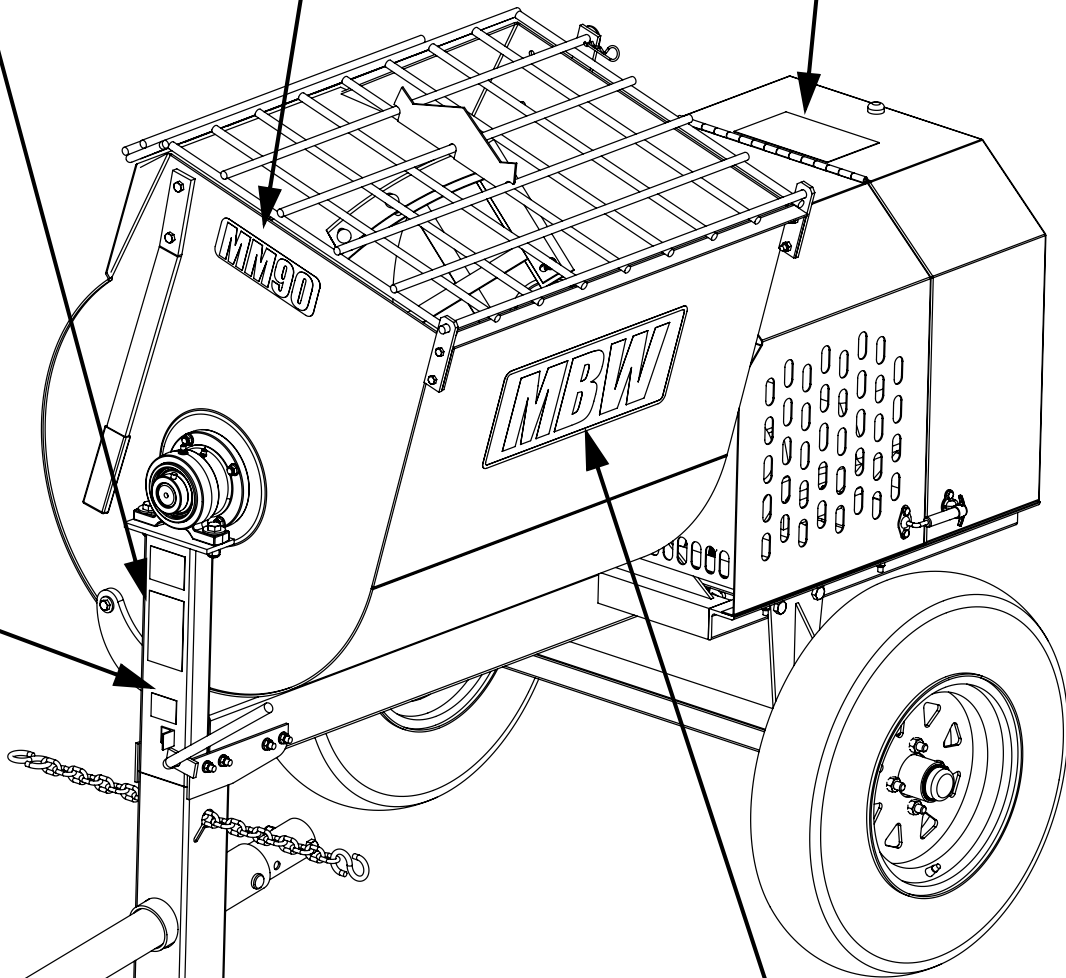

(2) 23173 - Not included with decal set

3Safety Decals (Decal Set #15074)

PUSH TO STOP PULSE PARA DETENER



16546



21740

MIXER(MEZCLADORA)
OPERATING INSTRUCTIONS
INSTRUCCIONES DE OPERACION

1. Check oil in engine crankcase.
2. MAKE SURE gear is CLOSED before starting and during operation.
3. Place engine lever in "IDLE" position before starting engine.
4. Open fuel valve.
5. Close choke on engine. A warm engine may not need to be choked.
6. Open throttle to "FAST" position.
7. Full starter rope.
8. After starting, turn choke off, let engine warm up at idle.
9. Open throttle to "FAST" position. CLOSE SENSITIVE. Place engagement lever in "MAX" position, charge mixer.
10. TO STOP: Place engagement lever in "IDLE" position, return throttle to IDLE, close fuel valve, press stop button.
11. Before leaving, check that drum is locked in lowering position, and tow pin is properly installed and in good condition.

Verificar el nivel de aceite en el cárter del motor.

2. CERCIORESE de que la palanca esté CERRADA antes del arranque y durante la operación.
3. Coloque la palanca de engranaje en la posición de "TALENTE" antes de arrancar el motor.
4. Abra la válvula de combustible.
5. Cierre el estrangulador del motor. Si el motor está frío, puede que no requiera estrangulamiento.
6. Abra el acelerador a la posición "RÁPIDA".
7. Tire de la correa de arranque.
8. Tras el arranque, apague el estrangulador y deje que el motor se caliente en ralentí.
9. Abra el acelerador y prográmo en la posición "MÁXIMA". CIERRE LA CUBIERTA. Coloque la palanca de engranaje en la posición de "MEZCLA", cargue la mezcladora.
10. PARA DETENERLA. Coloque la palanca de engranaje en la posición "TALENTE", vuelva el acelerador a ralentí, cierre la válvula de combustible y pulse el botón de parada.
11. Antes de abandonar, verifique que el tambor está bloqueado en la posición de descenso y, a su vez, el cerrojo está completamente instalado y en buen estado.

MAXIMUM TOW SPEED: 50 MPH
MÁX. VELOCIDAD DE REMOLQUE: 80 KPH

15071

WARNING
ADVERTENCIA



ENGINE EXHAUST IS HAZARDOUS IF INHALED
USE ONLY IN A WELL VENTILATED AREA
EL GAS DEL ESCAPE DEL MOTOR ES PELIGROSO SI SE INHALA
USE LA MÁQUINA SÓLO EN UNA ZONA BIEN VENTILADA

15076

15076

WARNING
ADVERTENCIA



MOVING PARTS CAN CRUSH AND CUT
KEEP HANDS CLEAR!
SHUT OFF ENGINE OR MOTOR BEFORE SERVICING.
LAS PIEZAS MÓVILES PUEDEN IMPACTAR Y CORTAR
¡MANTÉNTE ALEJADAS SUS MANOS!
APAGUE EL MOTOR ANTES DEL SERVICIO.

15069

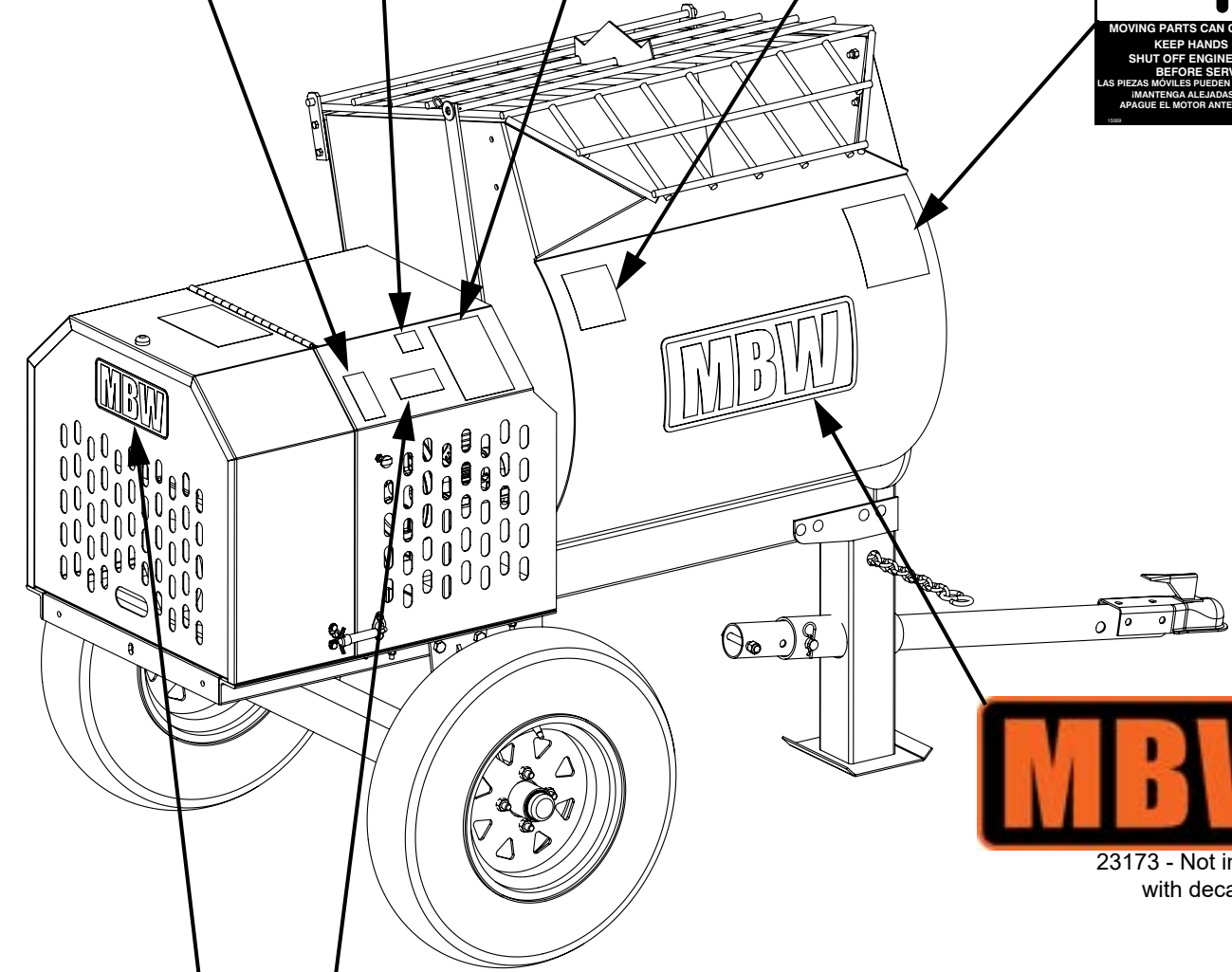

MBW

22531

WARNING

Operating, servicing and maintaining this equipment can expose you to chemicals, including engine exhaust, phthalates and lead, which are known to the state of California to cause cancer and birth defects or other reproductive harm. Avoid breathing engine exhaust. Do not operate equipment in confined areas. For more information go to www.P65Warnings.ca.gov

21820

MBW

23173 - Not included with decal set

Safety Decals (Decal Set)

WARNING
ADVERTENCIA



ROTATING PARTS can crush and cut.
Keep hands away!
Las PIEZAS GIRATORIAS pueden aplastar
y cortar.
¡MANTENGA LAS MANOS LEJOS DE EL-
LAS!

19446

19446

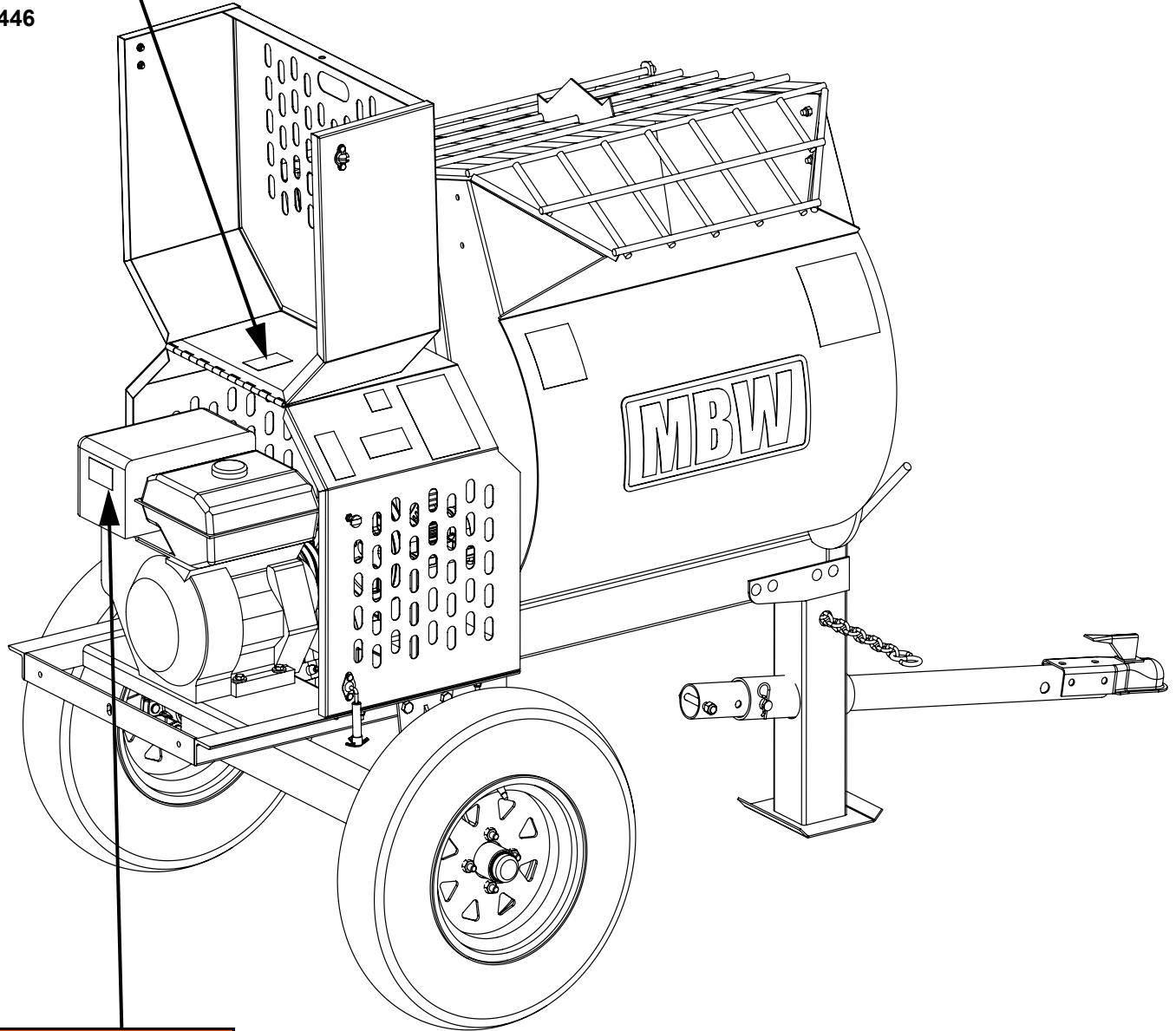

WARNING

OPERATION OF THIS EQUIPMENT MAY
CREATE SPARKS THAT CAN START FIRES
AROUND DRY VEGETATION. A SPARK
ARRESTER MAY BE REQUIRED. THE
OPERATOR SHOULD CONTACT LOCAL FIRE
AGENCIES FOR LAWS OR REGULATIONS
RELATING TO FIRE PREVENTION

19791

19791

Safety Decals (Decal Set #15074)

SPECIFICATIONS

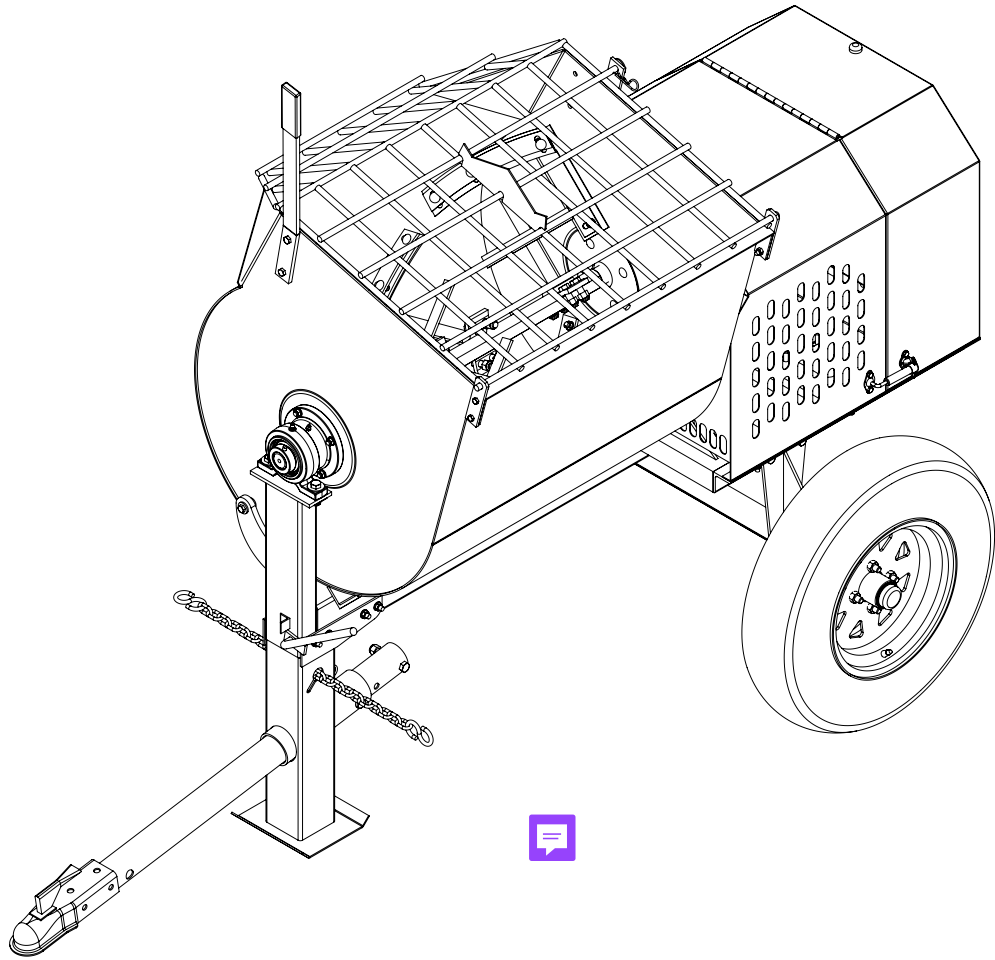

	MM90
Batch Capacity	9 cu. ft (0.26 cu. m)
Batch Size	3 - 3.5 bags
Gas Engines	Honda GX240
Engine Speed	3300 rpm
Drivetrain	V-belts to Gears
Electric Motors	Baldor 3 hp (1-phase)
Motor Draw	230V - 15.5A
Motor Speed	1725 rpm
Drivetrain	Chain to V-belts to Gears
Axle	46" Solid Axle
Wheels	ST175/80D13, High-Speed
Size - W x L x H	46 x 71 x 57 in, (117 x 180 x 145 cm)
Weight	730 lbs (331 kg)
Charging Height	49 in (124 cm)

Specifications subject to change without notice

OPERATION

Introduction

MBW equipment is intended for use in very severe applications. They are powered by four cycle engines and are available in different sizes and a selection of engines.

This parts manual contains only standard parts. Variations of these parts as well as other special parts are not included. Contact your local MBW distributor for assistance in identifying parts not included in this manual.

Before Starting & Operating

- **REMEMBER!** It is the owner's responsibility to communicate information on the safe use and proper operation of this unit to the operators.
- Review ALL of the Safety Precautions listed on page 1 of this manual.
- Familiarize yourself with the operation of the machine and confirm that all controls function properly.
- Know how to STOP the machine in case of an emergency.
- Make sure hands, feet, and clothing are at a safe distance from any moving parts.
- **OIL LEVEL** - Check the oil level in the engine. For more information see "Lubrication" under the respective engine's "Owners Manual" or the Maintenance section of this manual.
- **AIR CLEANER** - Check to ensure element is in good condition and properly installed.
- **FUEL SUPPLY** - The engines on MBW equipment require an automotive grade of clean, fresh, unleaded gasoline.
- **FUEL FILTER** - If clogged or damaged, replace.

Wiring Electric Motor

All electric motors come with a 12" pigtail which must be wired with a plug for your application.

 **WARNING** 
Wiring must be done by certified electrician.

Starting Gas Engine

1. Move mixer engagement lever to "IDLE" position.
2. Open the fuel valve.

3. Pull out the stop switch on the engine shroud.
4. Move the engine throttle lever to the "FAST" position.
5. Choke the engine if necessary. (You may not need to choke a warm engine).
6. Pull the starter rope repeatedly until engine starts.
7. Move choke lever to open position and throttle lever to the "IDLE" position
8. Allow engine to warm up for one or two minutes.

Starting Electric Motor

1. Move mixer engagement lever to "IDLE" position.
2. Plug the motor into a suitable power source.
3. Move the switch on the motor to the "ON" position.

Operating

1. Close the engine shroud.

 **WARNING** 
Do not operate the mixer with the shroud open.

2. Move engagement lever to the "MIX" position.
3. Add half of the required amount of sand and water for the batch to be mixed.
4. Add the total required amount of mortar mix.
5. Add the remaining amounts of sand and water and allow time to mix properly.
6. Unlock the drum by rotating the locking bar out of engagement with the frame.
7. Tip the drum forward to discharge the batch.
8. Return drum to mixing position and check that it is locked in place.
9. If another batch is to be mixed, add water for the next batch.

 **CAUTION** 
Always clean the drum after each day's operation. See Cleaning, page 8.

Stopping Gas Engine

1. Move mixer engagement lever to the "IDLE" position.
2. Whenever possible it is recommended to let the engine idle before stopping.
3. Push in the engine stop switch on the engine shroud.

4. Close the fuel valve.

Stopping Electric Motor

1. Move mixer engagement lever to the "IDLE" position.
2. Move the switch on the motor to the "OFF" position.



Always STOP the engine before adding fuel.

Always STOP the engine or motor before leaving the equipment unattended for any amount of time.

Always STOP the engine or motor and disconnect spark plug wire or power cord before making any repairs or adjustments to the machine.

Towing

1. Stop the engine or electric motor.
2. Close and latch the engine shroud.

3. Rotate the drum into the locked position, and check that it is locked in place.
4. Secure the mixer hitch and safety chains to the vehicle.



Always check that axle, front leg, and tow bar hardware is tight before towing.

Make sure safety bolt is in place.

Check the condition of the pin on the tow bar and make sure it is secure.

Remove any loose debris from the mixer before towing on roads.

Check that safety chains cross each other when attached.

MAXIMUM TOW SPEED: 50 mph

MAINTENANCE



WARNING



Always exercise the stopping procedure before servicing or lubricating the unit.

After servicing the unit, replace and fasten all guards, shields, and covers to their original positions before resuming operation.



CAUTION



Always verify fluid levels and check for leaks after changing fluids.

Do not drain oil onto ground, into open streams, or down sewage drains.

Maintenance Schedule

SYSTEM	MAINTENANCE	EACH USE	EVERY 40 HOURS	EVERY 100 HOURS	YEARLY
Axle	Check tire pressure		X		
	Grease wheel bearings				X
Drivetrain	Inspect drive belts for excessive wear		X		
	Oil electric motor drive chain		X		
	Grease bull gear teeth			X	
Drum	Grease trunnions & pillow blocks	X			
Engine	Refer to engine operator/owner manual	X			
Hardware	Check and tighten all hardware ^{1,2}				X

1. Check all hardware after the first 5 hours of use, then follow the maintenance schedule.
2. Re-torque lug nuts, front leg, and axle hardware after the first 25 miles traveled, then follow the maintenance schedule.

Engine Maintenance

Refer to the engine owner's manual for maintenance intervals and procedures.

Engine Speed

Engine speed is factory set according to the speeds listed in the Specifications section of this manual. Refer to the engine owner's manual for procedure on setting operating speed if necessary.

Cleaning

Always clean the mixer thoroughly after each day's operation. Dried mortar inside the drum can damage the paddles and shorten the life of the mixer. Additionally, future batches of mortar can be contaminated if the drum is not clean.



WARNING



Always stop engine or motor and disconnect spark plug wire or power cord before placing hands or objects inside drum.

Always reconnect safety grid opener to grid after cleaning drum.

Lubrication

1. Grease both trunnions and pillow blocks daily. There are two grease fittings on each end of the drum.
2. Apply a light coat of grease to the gear teeth once a month.
3. Oil all pivot points on the idler assembly once a week.
4. Electric mixers: Oil the drive chain once a week.



CAUTION



Do not beat on the drum to clean dried mortar; this will cause damage to the drum.

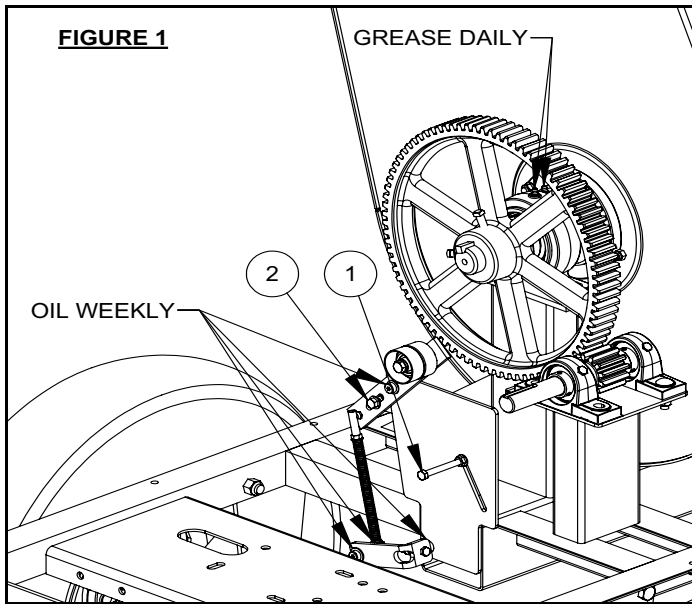

FIGURE 1

Greasing Wheel Bearings

1. Jack the rear end of the mixer and support by side rails so that mixer is stable.
2. Remove the wheel.
3. Remove the dust cover.
4. Remove the cotter pin from the spindle nut.
5. Unscrew the spindle nut.
6. Remove the hub from the spindle, being careful not to allow the outer bearing cone to fall out. The inner bearing cone will be retained by the seal.
7. Remove the grease seal.
8. Wash all grease and oil from the bearing cones and inspect each roller. If any pitting, spalling, or corrosion is present, then the bearing cup and cone must be replaced.
9. Pack the entire bearing with grease, apply a light coat of grease to the bearing cup, and install.
10. Tap a new grease seal into place with a clean block.
11. Slide the hub onto the spindle.
12. While rotating the hub slowly, tighten the spindle nut to approximately 50 lb-ft.
13. Loosen the spindle nut, but DO NOT rotate the hub.
14. Finger tighten the spindle nut until snug.
15. Back the spindle nut out slightly until the first castellation lines up with the cotter pin hole and insert the cotter pin.
16. Bend over the cotter pin legs to secure the nut.
17. Tap the dust cover into the hub.
18. Install wheel and torque lug nuts to 90 lb-ft.

Belt Guides

Belt driven models are equipped with guides to ensure proper operation. If the paddles do not stop when in the "IDLE" position, follow these steps to adjust them.

1. With engine stopped, move the engagement lever to the "MIX" position.
2. Loosen the nuts on the 3-1/4" long bolt (Figure 1, #1) below the drive belts. Move the bolt to within 1/16" of the belts and retighten the nuts.
3. Loosen nut on the 3/4" long bolt (Figure 1, #2) located in the slot on the idler arm.
4. Move engagement handle to "IDLE" position and start engine.
5. Move engagement handle towards "MIX" position until belts stop moving.
6. Slide 3/4" bolt and nut until they contact the edge of the frame and tighten.

SERVICE

Assembly and disassembly should be performed by a service technician who has been factory trained on MBW equipment. The unit should be clean and free of debris. Pressure washing before disassembly is recommended.

- Prior to assembly, wash all parts in a suitable cleaner or solvent.
- Check moving parts for wear and failure. Refer to the Replacement section in this manual for tolerance and replacement cycles.
- All shafts and housings should be oiled prior to pressing bearings. Also, ensure that the bearings are pressed square and are seated properly.
- All gaskets and seals should be replaced after any disassembly.

Torque Chart

SIZE	GRADE 2	GRADE 5	GRADE 8
1/4-20	49 in·lbs	76 in·lbs	9 ft·lbs
1/4-28	56 in·lbs	87 in·lbs	10 ft·lbs
5/16-18	8 ft·lbs	13 ft·lbs	18 ft·lbs
5/16-24	9 ft·lbs	14 ft·lbs	20 ft·lbs
3/8-16	15 ft·lbs	23 ft·lbs	33 ft·lbs
3/8-24	17 ft·lbs	26 ft·lbs	37 ft·lbs
7/16-14	24 ft·lbs	37 ft·lbs	52 ft·lbs
7/16-20	27 ft·lbs	41 ft·lbs	58 ft·lbs
1/2-13	37 ft·lbs	57 ft·lbs	80 ft·lbs
1/2-20	41 ft·lbs	64 ft·lbs	90 ft·lbs
9/16-12	53 ft·lbs	82 ft·lbs	115 ft·lbs
5/8-11	73 ft·lbs	112 ft·lbs	159 ft·lbs
5/8-18	83 ft·lbs	112 ft·lbs	180 ft·lbs
3/4-16	144 ft·lbs	200 ft·lbs	315 ft·lbs
1-8	188 ft·lbs	483 ft·lbs	682 ft·lbs
1-14	210 ft·lbs	541 ft·lbs	764 ft·lbs
1-1/2-6	652 ft·lbs	1462 ft·lbs	2371 ft·lbs
M 6	3 ft·lbs	4 ft·lbs	7 ft·lbs
M 8	6 ft·lbs	10 ft·lbs	18 ft·lbs
M 10	10 ft·lbs	20 ft·lbs	30 ft·lbs

CONVERSIONS

in·lbs x 0.083 = ft·lbs

ft·lbs x 12 = in·lbs

ft·lbs x 0.1383 = kg·m

ft·lbs x 1.3558 = N·m

Engine Shroud Removal

Refer to Drivetrain Assembly, page 16.

1. Disconnect wiring harness (#18) from engine by unscrewing ring terminal from engine and unplugging bullet connector.
2. Remove automatic safety grid lifter from safety grid.
3. Remove four bolts (#25), washers (#27), and locknuts (#26) securing shroud to frame.
4. Carefully lift shroud straight up to avoiding damaging engine or drive components. Approximate weight is 85 pounds.

Engine Shroud Installation

Refer to Drivetrain Assembly, page 16.

1. Lift shroud over engine and drive components and lower it straight down onto frame. Hold grid opener out of the way while lowering.
2. Align shroud with edges of frame and tighten bolts (#24) and locknuts (#26) in place.
3. Lift grid opener into position and pin to safety grid.
4. Connect wiring harness (#16) to engine by grounding the ring terminal to the engine and inserting the bullet connector into the splice terminal.

Drum Removal

Refer to Drum Assembly, page 14.

1. Remove engine shroud before attempting to remove mixing drum.
2. Mark the front and rear pillow block (#5) locations on the frame to aid in the alignment during installation.
3. Remove all four bolts (#26), washers (#28 & #10) and locknuts (#27) holding drum pillow blocks to frame.
4. If lifting drum by hoist, wrap chain around main shaft and pass chain through paddles to stabilize. If lifting drum by forklift, place blocks on forks to prevent drum from rolling. Approximate weight is 250 to 300 pounds, depending on model.

Drum Installation

Refer to Drum Assembly, page 14.

1. Lower drum onto frame supports. Pillow blocks (#5) should be snug to trunnions (#8) to eliminate excessive end-play.

2. Check alignment between bull gear and pinion. Gears must be parallel and in-line. Adjust drum location if necessary.
3. Bolt pillow blocks to frame using four bolts (#26), washers (#28 & #10) and locknuts (#27).
4. Dump drum to check for binding, if binding is noticed, loosen bolts and realign pillow blocks.
5. Loosen intermediate shaft bolts and fine tune gear alignment if necessary. Set backlash in gears to 0.010" before tightening. NOTE: It may be necessary to re-adjust alignment of drum or engine so that both sheaves line up properly.
6. Reinstall the engine shroud.
17. Lock collar in place by driving in the mixing direction.
18. Tighten set screw using a medium strength thread locking compound and torque to 20 ft. lbs.
19. Repeat process for rear bearing.
20. Begin pumping grease into trunnion cavity while rotating main shaft back and forth. NOTE: If grease comes out through ball bearing seals, check that grease shield (steel washer) is installed and that bearing is fully seated in trunnion and cannot move.
21. Continue pumping grease until drum seals "pop out" into drum. Clean any excess grease from inside drum.
22. Slide pillow blocks onto trunnions and grease until a film of grease is seen all around the trunnion.
23. Reinstall the bull gear. Tighten set screws using a medium strength thread locking compound.
24. Reinstall mixing drum onto frame. See Drum Installation, page 10.

Drum Bearing & Seals Replacement

Refer to Drum Assembly, page 14.

1. Remove mixing drum from mixer. See Drum Removal, page 10.
2. Loosen set screws and remove bull gear from main shaft. Use a puller if necessary.
3. Slide pillow blocks (#5) off of trunnions (#8).
4. Loosen set screw and remove locking collars from trunnion bearings (#4) by rotating the collars against the mixing direction of the paddles.
5. Remove four bolts (#20) and nuts (#23) holding each trunnion to the drum.
6. While supporting the main shaft, slide the trunnion off of each end.
7. Pull the triple seal kit (#9) out of the back side of each trunnion and discard.
8. Remove the retaining ring (#7) from each trunnion.
9. Remove the ball bearing and grease shield (steel washer) from the front side of each trunnion.
10. Inspect the bearings, and replace both if needed.
11. Thoroughly clean all grease from the trunnions.
12. Apply a medium strength thread locking compound to each outer bearing surface and reinstall the bearings and grease shields into the trunnions.
13. Reinstall the retaining rings.
14. Install new seal kits into the back side of each trunnion in the following order: Steel Washer, Soft Black Seal, Steel Washer, Soft Black Seal, Steel Washer, Hard Red Seal.
15. Slide trunnions onto each shaft end and bolt in place.
16. Slide bearing locking collar onto front shaft end and align shaft flush with collar.

Engine Removal

Refer to Drivetrain Assembly, page 16.

1. Disengage mixer by moving engagement handle to "IDLE" position.
2. Disconnect wiring harness (#16) from engine by unscrewing ring terminal from engine and unplugging bullet connector.
3. Remove four bolts (#29), washers (#32), lock washers (#31) and nuts (#30) holding engine to frame.
4. Tilt engine and remove drive belts.
5. Lift engine off of frame.

Engine Installation

Refer to Drivetrain Assembly, page 16.

1. Set engine onto frame and line up with holes.
2. Disengage idler by moving engagement handle to "IDLE" position and install both drive belts.
3. Install four bolts, washers, lock washers, and nuts to secure engine. Check for proper alignment between both sheaves (#4 & #5) with a straightedge before tightening hardware.
4. Connect wiring harness (#16) to engine by grounding the ring terminal to the engine and inserting the bullet connector into the splice terminal.

Parts Replacement Cycles and Tolerances

Bearings	Replace anytime a bearing is rough, binding, discolored or removed from housing or shaft.
Clutch	Replace clutch if it does not disengage below 1800 rpm.
Engine Components	Refer to your engine manufacturer's Owner's Manual.
Hardware	Replace any worn or damaged hardware as needed. Replacement hardware should be grade 5 and zinc plated unless otherwise specified.
Safety Decals	Replace if they become damaged or illegible.
Seals & Gaskets	Replace if a leak is detected and at every overhaul or tear down.
V-Belts	Replace if cracked, torn, or stretched to the point the belt won't tension properly.

REPLACEMENT PARTS

The warranty is stated in this book on page 24. Failure to return the Warranty Registration Card renders the warranty null and void.

MBW, Inc. has established a network of reputable distributors with trained mechanics and full facilities for maintenance and rebuilding, and to carry an adequate parts stock in all areas of the country. Their sales engineers are available for professional consultation. If you cannot locate an M-B-W distributor in your area, contact MBW, Inc. or one of our Sales Branches listed below.

When ordering replacement parts, be sure to have the following information available:

- Model and Serial Number of machine when ordering M-B-W parts
- Model and Serial Number of engine when ordering engine parts
- Part Number, Description, and Quantity
- Company Name, Address, Zip Code, and Purchase Order Number
- Preferred method of shipping

REMEMBER - You own the best! If repairs are needed, use only M-B-W parts purchased from authorized M-B-W distributors.

Write Model Number here

Write Serial Number here

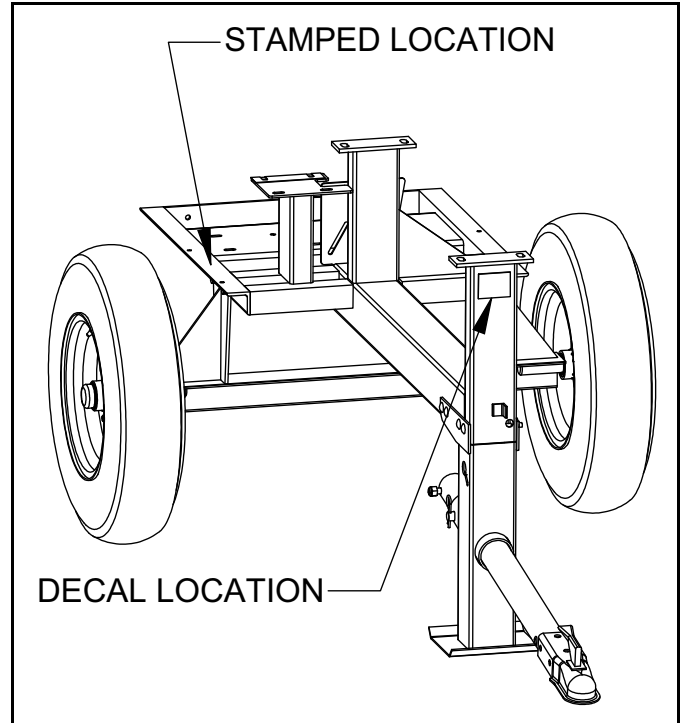

The unit's serial number can be found in the following locations:

- The model/serial number decal is located on the front drum support, below the pillow block.
- The serial number is stamped on the mixer frame between the shroud mounting holes.

Contact Information

MBW, Inc.

250 Hartford Rd • PO Box 440
Slinger, WI 53086-0440
Phone: (262) 644-5234
Fax: (262) 644-5169
Email: mbw@mbw.com
Website: www.mbw.com

MBW Europe Ltd.

Units 2 & 3 Cochrane Street
Bolton BL3 6BN, England
Phone: + 44 (0) 01204 387784
Fax: + 44 (0) 01204 387797
Email: saleseurope@mbw.com
Website: www.mbw europe.com

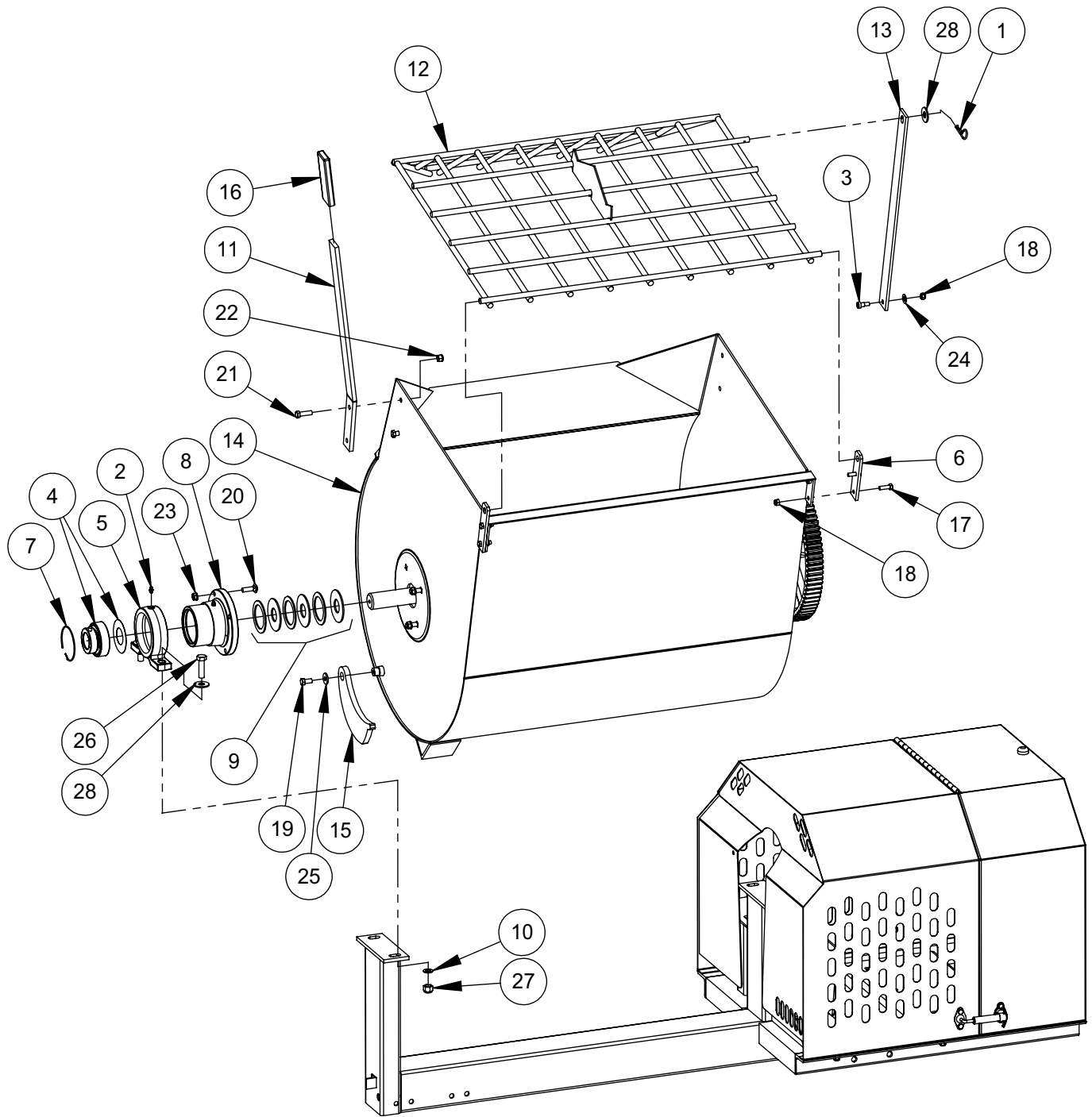

Drum Assembly

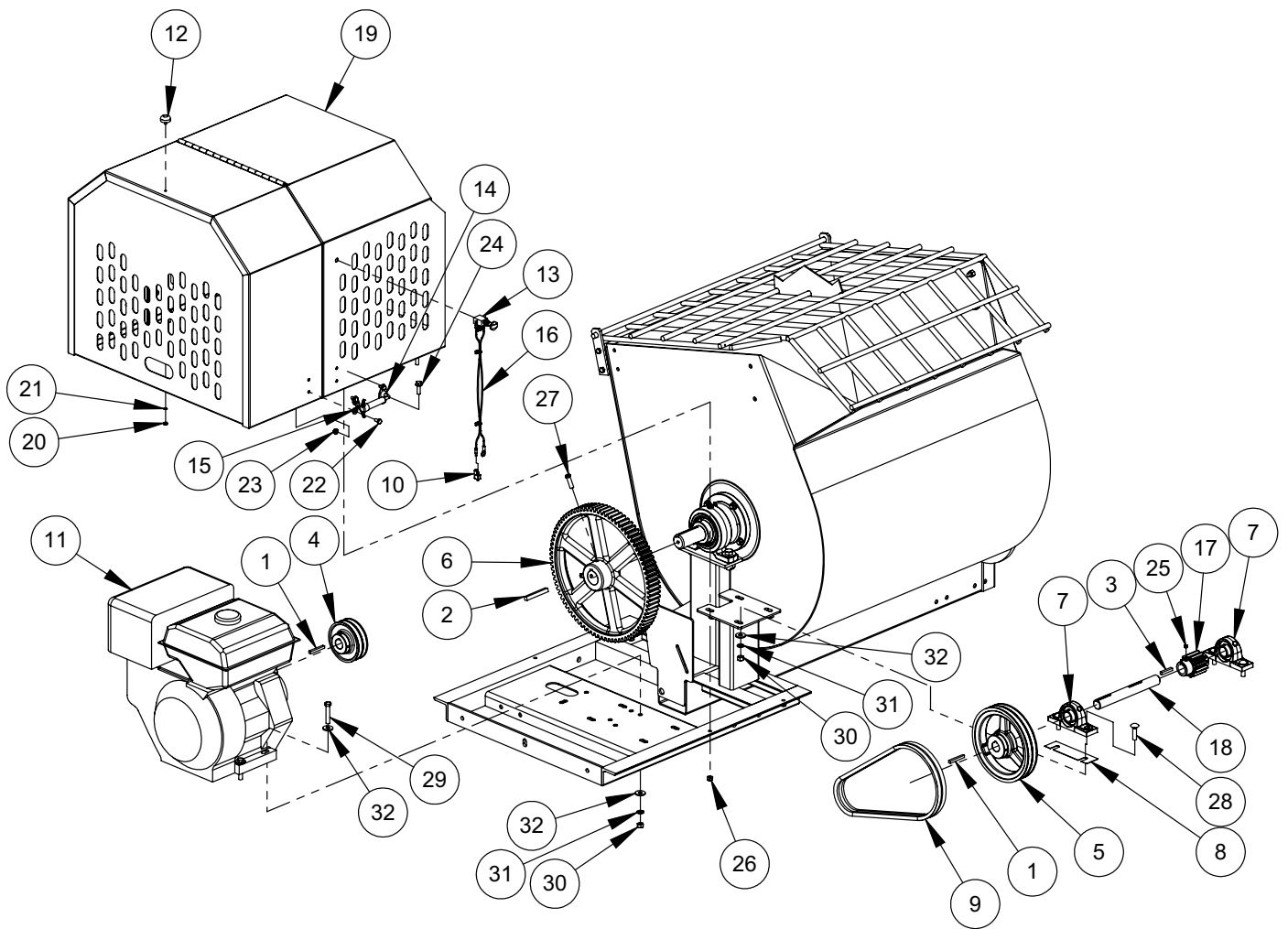

Drivetrain Assembly

ITEM	PART NO.	DESCRIPTION	MM90
1.	00808	KEY, 1/4" SQUARE x 1-3/4" LG.	2
2.	01159	KEY, 3/8" SQUARE x 2-3/4" LG.	1
3.	01161	KEY, 1/4" SQUARE x 1-1/2" LG.	1
4.	01561	SHEAVE, 2A - 4" (8 hp Honda)	1
5.	01562	SHEAVE, 2A - 8"	1
6.	01563	SPUR GEAR, 84 TOOTH	1
7.	05586	BEARING, PILLOW BLOCK	2
8.	05692	SHIM, MIXER (AS REQUIRED)	1
9.	05741	V-BELT, AX-38	2
10.	07592	TERMINAL, SPLICE	1
11.	07755	ENGINE, HONDA 8 HP	1
12.	16750	BUMPER, RUBBER	1
13.	16783	SWITCH	1
14.	16813	LATCH, METAL	2
15.	16816	CATCH PLATE, METAL LATCH	2
16.	16820	HARNESS, WIRING	1
17.	21651	PINION GEAR, 12 TOOTH	1
18.	21652	INTERMEDIATE SHAFT	1
19.	21658	SHROUD ASSEMBLY (Includes 12,14,15 & 20-23)	1
20.	F0324HN	HEX NUT, #10-24	1
21.	F03LW	LOCKWASHER, #10	1
22.	F042004HCS	HEX HEAD CAP SCREW, 1/4-20 x 1/2"	8
23.	F0420FN	FLANGE NUT, 1/4-20	8
24.	F051808FWS	FLANGE BOLT, 5/16-18 x 1"	4
25.	F052402SSS	SOCKET HEAD SET SCREW, 5/16-24 x 1/4 LG.	1
26.	F0518ELN	HEX HEAD CAP SCREW, 5/16-18	4
27.	F061610SHS	SQUARE HEAD SET SCREW, 3/8-16 x 1-1/4"	2
28.	F061612CB	CARRIAGE BOLT, 3/8-16 x 1-1/2"	4
29.	F061616HCS	HEX HEAD CAP SCREW, 3/8-16 x 2"	4
30.	F0616HN	HEX NUT, 3/8-16	8
31.	F06LW	LOCKWASHER, 3/8"	8
32.	F06SW	WASHER, 3/8"	12
SERVICE PARTS			
	21650	INTERMEDIATE SHAFT ASSEMBLY, (Includes items 3, 7, 17, 18 & 25)	

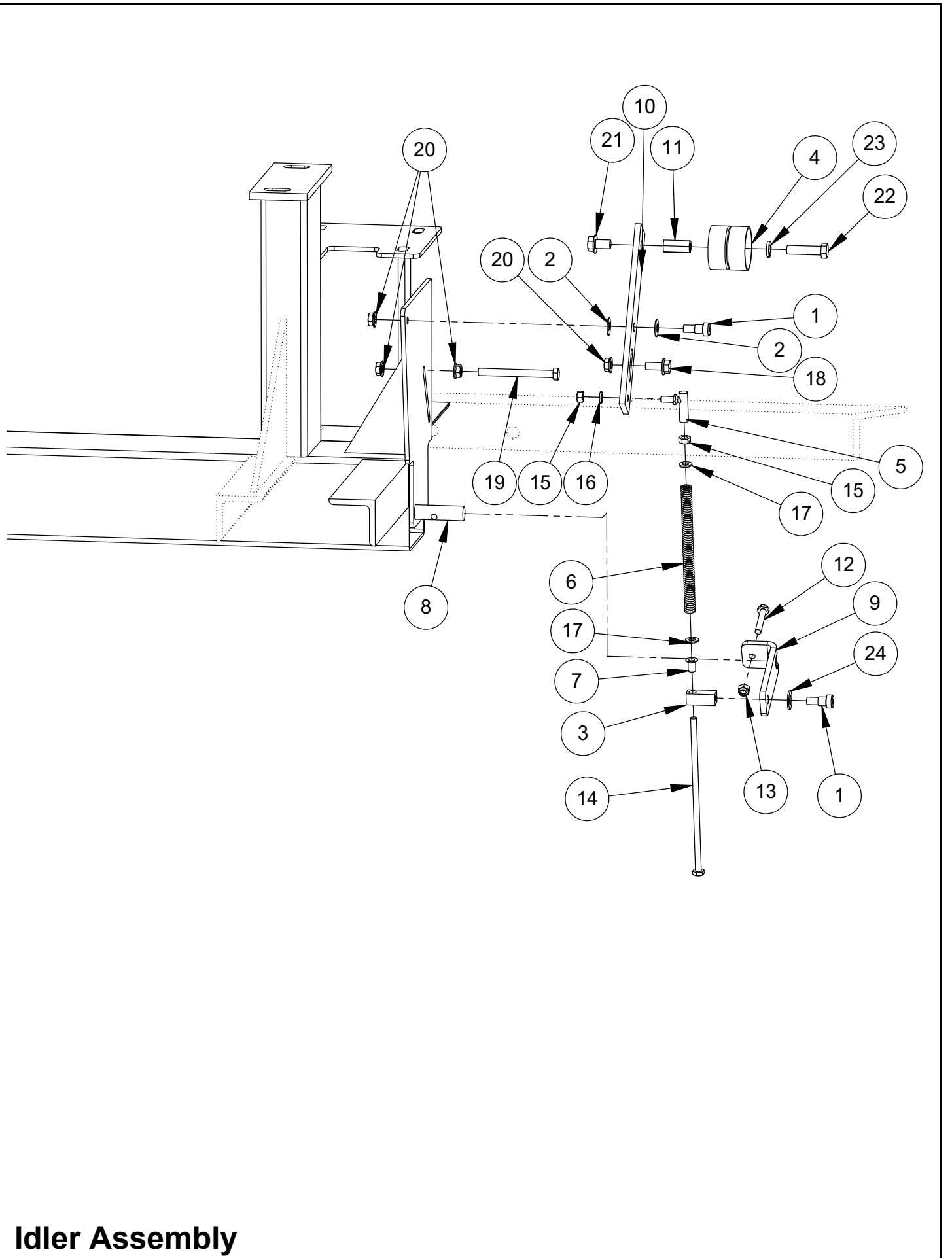

Idler Assembly

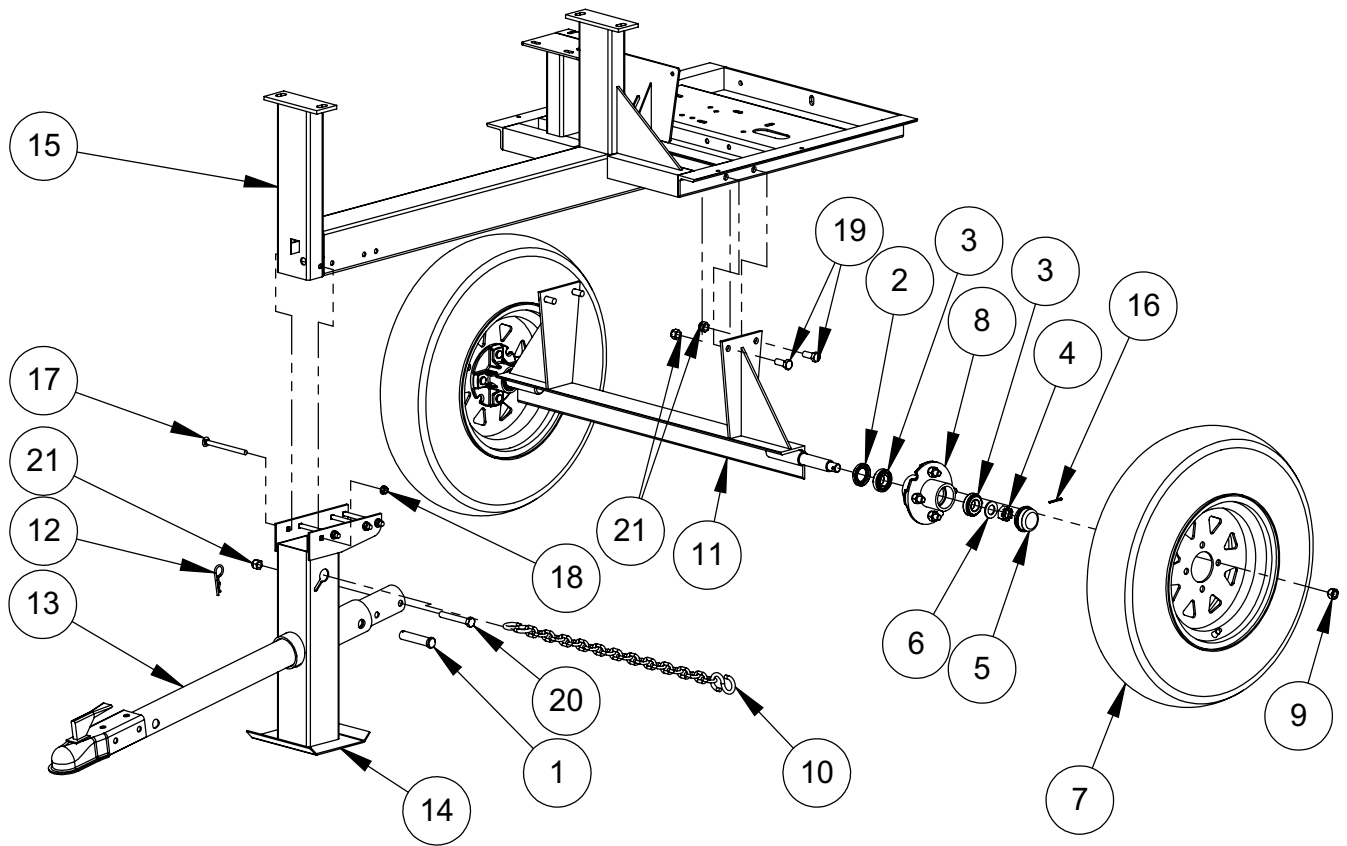

Frame & Axle Assembly

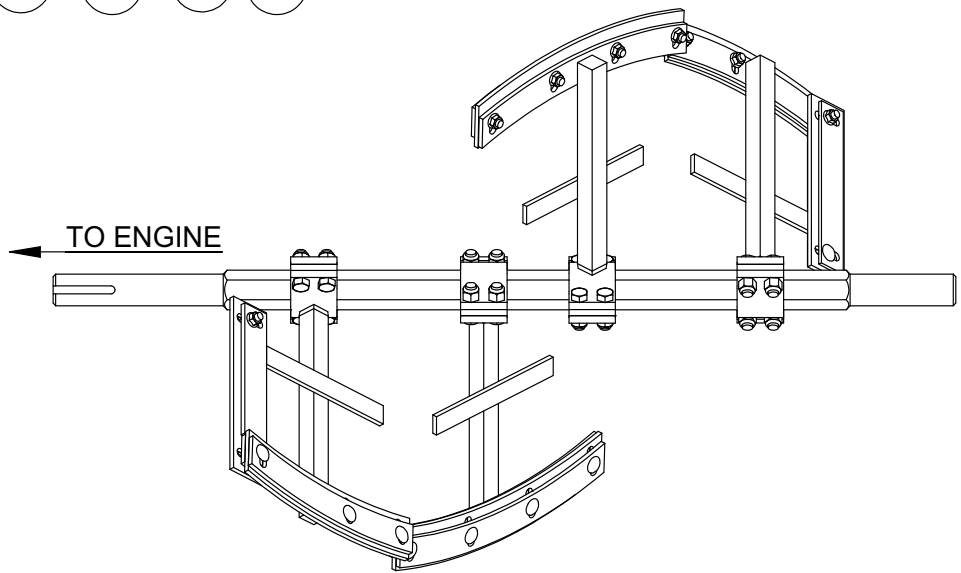
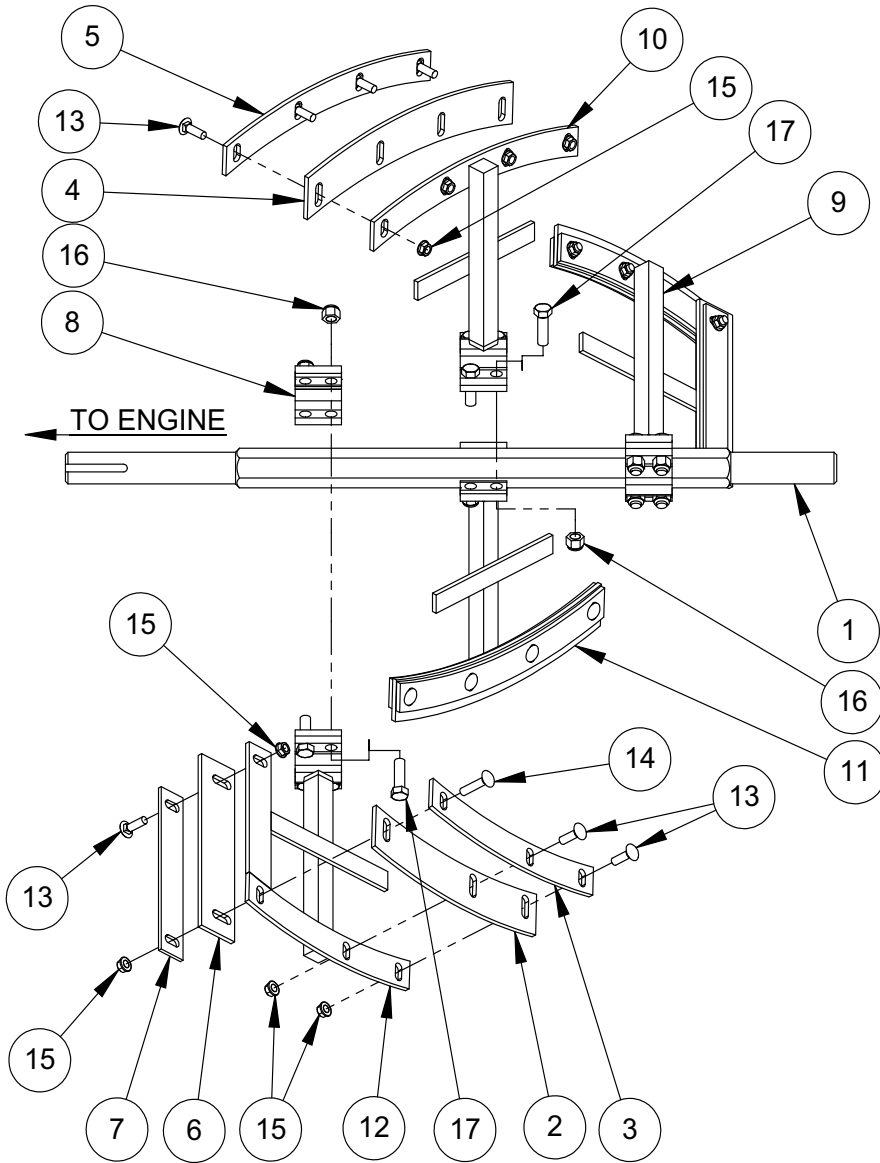

MM90 PADDLE ORIENTATION

Paddle Assembly

WARRANTY

1. IN GENERAL - The warranties described in this document are provided by M-B-W, INC. and MBW EUROPE, LTD. ("MBW") to define what is, what is not, and for how long machines and parts are covered against material defects and/or defective workmanship. To obtain warranty service, the purchaser must, within the Warranty Period (defined in Paragraph 3): (i) report the product defect to an authorized repair center, (ii) make a written request for repair, (iii) provide proof of purchase to the authorized repair center, and (iv) deliver the equipment to the authorized repair center. A list of authorized repair centers is available on the MBW website (mbw.com) or by contacting MBW at 800-678-5237.

2. COVERED - MBW's obligation under this limited warranty is limited to the cost of the parts and the labor to repair any defect in material and/or workmanship at an authorized MBW repair center. Transportation charges are not covered by this limited warranty.

3. WARRANTY PERIODS - The Warranty Period begins on, as applicable: (i) the product purchase date by an end user or (ii) the first day the product is put into rental or two years after invoice date from MBW to Dealer, whichever starts the warranty period first. To insure that your warranty is in place, fill out the warranty card and mail it in or register your product online at www.mbw.com/service-support/warranty-registration. The warranty is nontransferable.

The Warranty Period ends after:

- A. New Ground compaction equipment - 2 years.
 - B. New Concrete finishing equipment - 1 year.
 - C. New Utility equipment - 1 year.
 - D. Demonstration equipment - 6 months.
 - E. Wear parts: lubricants, filters, belts and shock mounts - 30 days.
4. NOT COVERED- This warranty does not include, and MBW specifically excluded from any warranty:
- A. Used equipment - all used equipment is not warranted and is sold 'as is' 'where is' with all defects.
 - B. Replacement electrical parts, including but not limited to: electric motors, circuit boards, switches, are not warranted or returnable.
 - C. OEM: engines, batteries, and chargers. Those warranties are covered by the manufacturer.
 - D. Consumable parts: trowel and screed blades.
 - E. Equipment that has been: altered, abused, neglected, not maintained, or modified to run outside its specifications. Any modification to the machine or its parts makes this warranty null and void.
 - F. Other: damage to a product from normal wear, air freight, overtime, pickup and delivery, temporary replacement rentals, freight damage, or other similar incidents.
 - G. Product used in a fashion it was not designed for.
 - H. Parts and labor not performed by authorized dealers.

It is at MBW's discretion if warranty applies and has the right to adjust labor rates on a claim by claim basis.

5. OTHER - IT IS EXPRESSLY AGREED THAT THIS SHALL BE THE SOLE AND EXCLUSIVE REMEDY UNDER THIS WARRANTY. UNDER NO CIRCUMSTANCES SHALL MBW BE LIABLE FOR ANY COSTS, LOSS, EXPENSE, DAMAGE, SPECIAL DAMAGES, DIRECT DAMAGES, INCIDENTAL DAMAGES, EXEMPLARY, CONSEQUENTIAL, OR PUNITIVE DAMAGES ARISING DIRECTLY OR INDIRECTLY FROM THE USE OF MBW PRODUCT OR DAMAGES FOR LOSS OF USE, LOSS OF ANTICIPATED PROFITS, INCOME, OR ECONOMIC LOSSES OF ANY KIND. MBW'S LIABILITY TO BUYER UNDER THESE WARRANTIES FOR THE PRODUCT IS LIMITED AS SET FORTH HEREIN, WHETHER BASED UPON WARRANTY, CONTRACT, NEGLIGENCE, TORT, STRICT LIABILITY OR ANY OTHER THEORY OF LIABILITY, INCLUDING BUT NOT LIMITED TO FRAUD, MISREPRESENTATION, BREACH OF CONTRACT, PERSONAL INJURY, PRODUCTS LIABILITY OR ANY OTHER THEORY.

MBW'S LIABILITY UNDER ANY WARRANTY HEREUNDER, WHETHER EXPRESS OR IMPLIED, SHALL NOT EXCEED THE COST OF REPAIR OR REPLACEMENT OF DEFECTIVE PARTS OF THE PRODUCT OR THE PRODUCT. BUYER MAY NOT BRING ANY ACTION UNDER THESE WARRANTIES MORE THAN ONE YEAR AFTER THE CAUSE OF ACTION HAS ACCRUED.

THE FORGOING WARRANTY IS EXPRESSED IN LIEU OF ALL OTHER WARRANTIES, EXPRESSED OR IMPLIED, INCLUDING THE WARRANTIES OF MERCHANTABILITY, FITNESS FOR USE, AND FITNESS FOR A PARTICULAR PURPOSE, AND ALL OTHER OBLIGATIONS OR LIABILITY ON MBW'S PART. MBW SPECIFICALLY DISCLAIMS AND EXCLUDES ANY AND ALL WARRANTIES OF MERCHANTABILITY AND FITNESS FOR A PARTICULAR PURPOSE.

MBW NEITHER ASSUMES NOR AUTHORIZES ANY OTHER PERSON TO ASSUME ON BEHALF OF MBW ANY OTHER LIABILITY OR WARRANTY IN CONNECTION WITH THE SALE OR SERVICE OF ANY MBW PRODUCT.

Some states do not allow limitations on how long an implied warranty lasts, so the above limitation may not apply to you. This warranty gives you specific legal rights, and you may also have other rights which vary from state to state.

NOTES