

# MORTAR MIXER POWERED BY HONDA



# MBW

BUILDING A BETTER JOBSITE EXPERIENCE

[ MM90 ]

[MBW.COM](http://MBW.COM)



# MORTAR MIXER

## MORTAR MIXER



We are confident in the superior craftsmanship and durability of MBW's mixers, and we invite you to see the difference for yourself.

The things to compare include:

- Paddle shaft and clamping design
- Bearing capacity
- Trunnion and pillow block quality
- Frame strength
- Drive gears
- Belt tension mechanism
- Drum latch/lock system
- Drum and grid weldments
- Engine shroud
- Front leg design
- Material types
- Gauge of steel throughout the mixer

In an industry where cost-cutting and outsourcing overseas often leads to declining quality, MBW stands apart. While many manufacturers prioritize lower production costs, resulting in decreased overall mortar mixer quality and lifespan over the past 30 years, MBW takes a different approach.

At MBW, we refuse to compromise on quality. Though you may invest a bit more in an MBW Mortar Mixer, the returns of reduced maintenance and extended lifespan make it a wise choice.

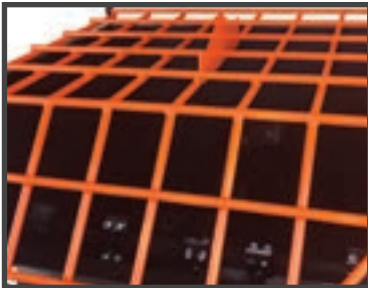

MODEL	MM90
Batch Capacity	9.0 cu. ft (0.26 cu. m) 3-3.5 bags
Drum Wrap End Plates	10 Gauge 7 Gauge
Standard Axle	46" Solid Axle
Wheel	ST175/80D13 High-Speed
Size	46 x 71 x 57 in (117 x 180 x 145 cm)
Weight	730 lbs (331 kg)
Engine Options	Honda GX240
Engine/Shaft Speed	3300/39 rpm
Drive	V-belts to Gears

( ) Metric Measurements

# MORTAR MIXER

## MIXER FEATURES

### SPRING TENSION IDLER SYSTEM

Eliminates belt adjustments

### RIGID ENGINE DECK

For secure mounting

### DOUBLE LOCKING PIN SYSTEM

For tow pole safety

### HEAVY-DUTY CAST BULL GEAR

For extra long life

### REMOVABLE FRONT LEG

To rigidly affix to a trailer or replace easily if damaged

### BALL HITCH

Comes standard  
*Optional pintle hitch sold separately*



### SINGLE PIECE SELF OPENING/CLOSING GRATE COVER

For extra strength and safety

### STEEL PADDLE SHAFT CLAMPS

Provides maximum drive power without slippage

### 1-5/8" SOLID HEX SHAFT

Extra strength, no welding, machined

### TRIPLE SEAL

3 synthetic seals. 3 metal washers

### HANDS FREE

Drum locking mechanism enhances operation and increases safety

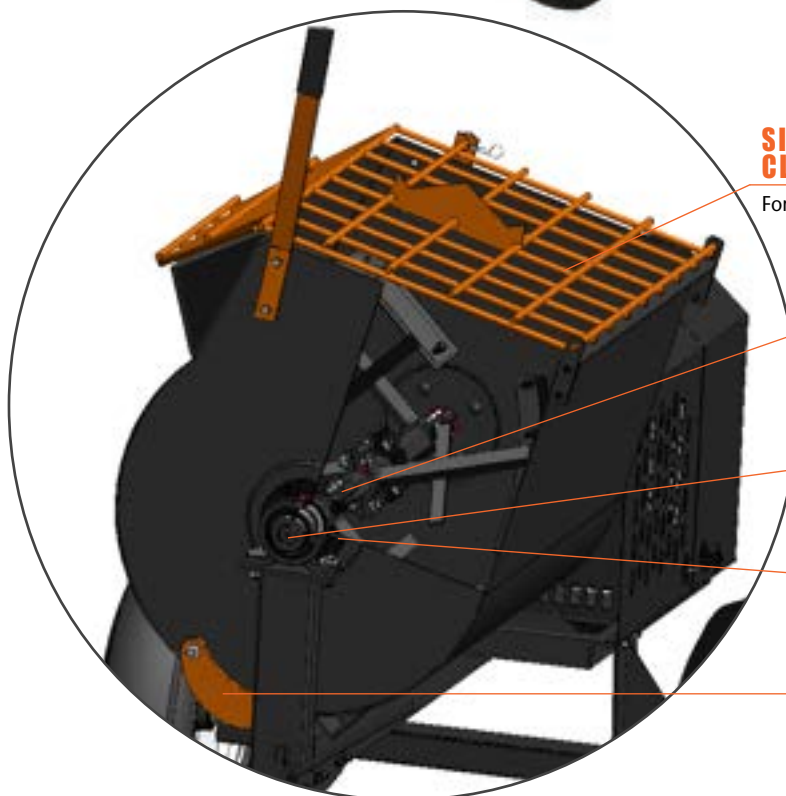

## ABOUT MBW INC.

Since 1967, MBW has been at the forefront of manufacturing innovative compaction, concrete, and related equipment for the construction industry.

### WHAT SETS MBW APART?

MBW doesn't simply follow the crowd; we innovate. Each new engineering project begins with the belief that there is always room for improvement—whether in productivity, maintenance, longevity, user safety, or cost-effectiveness. Our research and development often lead to groundbreaking solutions that set new standards in the industry. MBW products enhance productivity, provide the safest tools in their class, address long-standing maintenance issues, and extend product lifespans. **Our mission is to offer equipment users significant, tangible value—clear reasons to choose MBW products.**



**SCREEDS**



**TROWELS**



**ROLLER ATTACHMENTS**



**RAMMERS**



**VIBRATORY PLATES**



*MBW Inc.*  
250 Hartford Road • P.O. Box 440  
Slinger, Wisconsin • 53086-0440 • USA  
Ph: 800-678-5237 or 262-644-5234 • Fax: 262-644-5169  
E-mail: [mbw@mbw.com](mailto:mbw@mbw.com) • Website: [www.mbw.com](http://www.mbw.com)

*MBW Europe Ltd.*  
Units 2 & 3 Cochrane Street • Bolton BL3 6BN • England UK  
Ph: 44 (0) 1204 387784 • Fax: 44 (0) 1204 387797  
E-mail: [mbwuk@mbw.com](mailto:mbwuk@mbw.com) or [mbweurope@mbw.com](mailto:mbweurope@mbw.com)  
Europe Website: [www.mbweurope.com](http://www.mbweurope.com)



## AUTHORIZED DISTRIBUTOR

L16484 10/24  
Copyright ©  
MBW Incorporated  
All Rights Reserved