

MEC17 HYDRAULIC EXCAVATOR



Operator's Manual

CROBA

READ AND UNDERSTAND THE ENTIRE MANUAL BEFORE OPERATING MACHINE

FOREWORD

The Operator's Manual is used for safety guidelines and the correct use and maintenance of the machine. The operation and maintenance steps described are the most effective methods for operation and maintenance. Following these instructions helps to ensure the effectiveness, economy and reliability of equipment maintenance. Careful reading of the relevant contents of "NOTICE" and "WARNING" in the driver's manual will minimize the risk of casualties and machine damage or unsafe factors caused by improper maintenance.

WARNING



- **Before starting and operating the machine for the first time, and before repairing the machine, you should read the instructions carefully and understand thoroughly.**
- **Read the safety messages and safety labels given in this manual carefully so that they should be understood fully.**
- **This manual should always be placed next to the machine for easy reference, if the manual is lost, damaged or illegible should be replaced.**
- **When you sell the machine, make sure that this manual should be provided to the new owner together with the machine**

NOTICE

- This manual is applicable to MEC17.
- This manual has been adapted to all markets. Optional and special equipment from different markets should be ignored because they may not be suitable for your machine.
- We reserve the right to modify and improve technical data, specifications, design, operation and maintenance instructions of the product without prior notice.
- It is forbidden to modify the electrical system of the machine. If any abnormal or damaged components are caused by this, the company will not be responsible for it.

The location of the Operator's Manual

- Storage location for the Operator's Manual:
- magazine box on the back of operator's seat.

In addition to this manual, please refer to the instruction manual of the engine for details on the use, maintenance, and troubleshooting of the engine.



In the book where the requirements for the safety of people, machine and important technology in place, all have symbol prompts  and , please bear in mind.

TABLE OF CONTENTS

TABLE OF CONTENTS	2		60
SAFETY REGULATIONS	4	Steering the Machine	60
Vehicle Operation and Maintenance	4	Swinging	61
EQUIPMENT OUTLINE	5	Work Equipment Controls and Operations	61
Introduction	5	Operation with Hook Bucket	63
SAFETY	10	Permissible Depth of Water	66
Warning Signs and Illustrations	10	Traveling on Slopes	67
Safety Machine Operation	22	Cold Weather Operation	68
Transport	27	After Daily Work Completion	68
Battery	28	After Cold Weather Season	69
Battery Safety Operation	28	Long Term Storage	69
Towing and Being Towed	30	Troubles and Actions	70
Lifting Work	30	Others Malfunction	75
Safety Maintenance Information	31	Electrical System	76
OPERATION	35	MAINTENANCE	79
General Drawing of Control Device	35	Maintenance Information	79
Description of Instrument and Control Device	36	Lubricants, Fuels and Coolants	80
Other Control Devices	43	Wear Parts	83
Equipment Lock	46	Correct Selection	84
Battery Disconnect Switch	47	Tightening Torque Specifications	84
Machine Operations and Controls	48	Safety critical parts	86
Checks before Starting	48	Maintenance Interval for Hydraulic Breaker	89
Coolant Level: Check or Add	49	Maintenance procedures	89
Oil Level in Engine: Check or Add	49	Fan belt - check/adjust	90
Fuel Level: Check or Add	50	Fuel system maintenance and maintenance	91
Oil Level of Hydraulic :Check or Add	51	Fuel system - exhaust	92
Air Cleaner Dust Indicator (optional): Check	52	Maintenance of cooling system	92
Electric Wiring: Check	53	Internal cooling system - cleaning/replacement	93
Seat Adjustment	53	Air filter maintenance and maintenance	93
Operations before Starting Engine	54	Operation instructions for electric welding	97
Starting Engine	55	Maintenance of Hydraulic System	97
Starting Engine in Cold Weather	56	Hydraulic Oil Replace	98
Warming up operation	57	Hydraulic System - Exhaust	100
Machine Operation: Move and Stop	58	VIBRATORY COMPACTOR QUALITY WARRANTY	103
Moving Machine Backward	59	CERTIFICATE	
Stopping Machine	60	Operator Instructions	103

Eccentric Assembly Maintenance and Usage	103
Pipeline	103
Hydraulic Oil Usage	103
Bolts and Nuts Usage & Maintenance	103
Operating Method	103
Special Notes	103
Warranty Scope	104
Special Notes for Hydraulic Vibratory Compactor Use	104
SPECIFICATION	105
Specifications	105
Working Ranges	107
Lifting Capacity Form	108
Standard Configuration and Digging Force	109
Operating Weight and Ground Specific Pressure	109
ATTACHMENTS AND OPTIONS	110
Safety First	110
Precautions when removing or installing	110
Attachment Installation	111
Recommended Attachment Operations	111
Hydraulic Breaker	111
Prohibited Works	112
Supply Grease in the Correct Position	113

SAFETY REGULATIONS

To operate and use the machine, you must follow the rules and regulations issued by national, provincial, autonomous region, and government. Therefore, the operating instructions and safety information contained in this manual are merely some helpful advice.

The following symbols together with texts mean the following as they appear in this manual:

WARNING



- **Warning, keep alert! It concerns your own safety!**
- **Ignorance of such risk may result in accident, serious injury even death.**
- **It's the operator's liability to ensure that all warning signs are kept on the machine in good condition and legibly. Otherwise accident is most likely to occur.**
- **Familiarize with the functions and limitations of the machine.**

In addition to the above, the following signal words are used to indicate precautions that should be followed to protect the machine or to give information that is useful to know.

NOTICE

This word indicates that when the wrong operation is carried out, it may cause damage to the machine or shorten the service life of the machine.

REMARKS

This word is used for information that is useful to know.

Vehicle Operation and Maintenance

WARNING



- **Before operating the machine, the operator must have sufficient operational skills and have read up and understood the related content of the manual.**
- **Untrained operators may result in the risk of serious injury or personal death.**
- **Never use a machine without the Operator's Manual.**
- **Before operating this machine, familiarize with various warning signs, symbols and the operator's manual of this vehicle.**

PERSONAL SAFETY

Do not permit children to operate this machine at any time.

Keep children, pets, and other people not using the unit away from the work area. Be alert and shut off unit if anyone enters work area. Keep children under the watchful care of a responsible adult.

Do not operate the machine while under the influence of drugs, alcohol, or any medication that could affect your ability to use it properly.

EQUIPMENT OUTLINE

Introduction

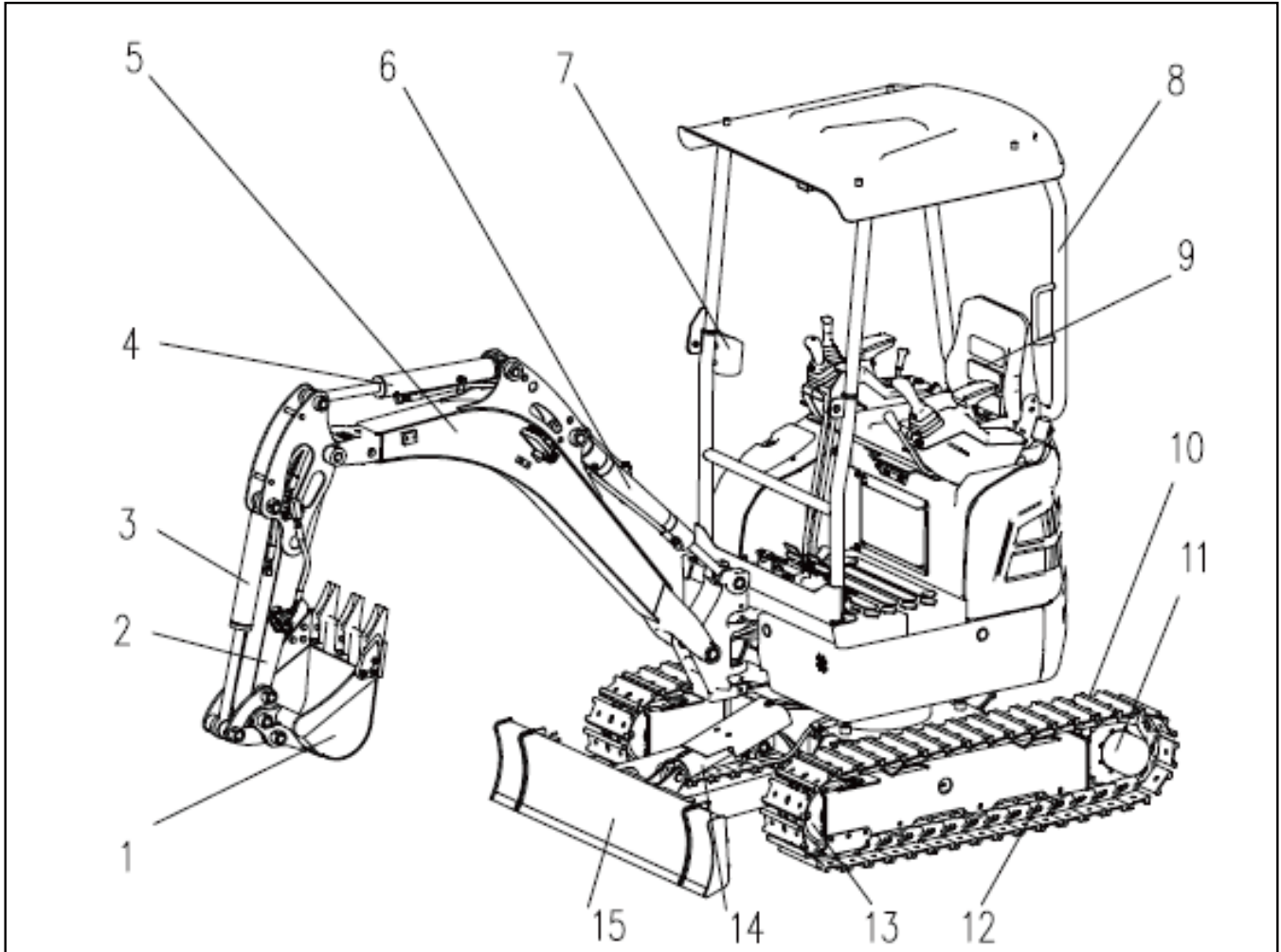

1. Bucket

2. Arm

3. Bucket cylinder

4. Arm cylinder

5. Boom

6. Boom cylinder

7. Water cup holder

8. Driver's shed

9. Seat

10. Track

11. Traveling motor and drive sprocket

12. Support wheels

13. Increase assembly

14. Bulldozer cylinder

15. Bulldozer

Specified Use

The machine is intended to be used under normal conditions for the applications described in this manual. If it is used for other purposes or in potentially dangerous environments, for example explosive atmosphere, flammable environment or areas with dust containing asbestos and so on, special safety regulations must be followed and the machine is equipped for such use.

Engine

MEC17 Engine is 3 cylinders, 4 stroke, water-cooling, 0.898L displacement, KUBOTA D902 type, rated power: 11.8kW/2300rpm.

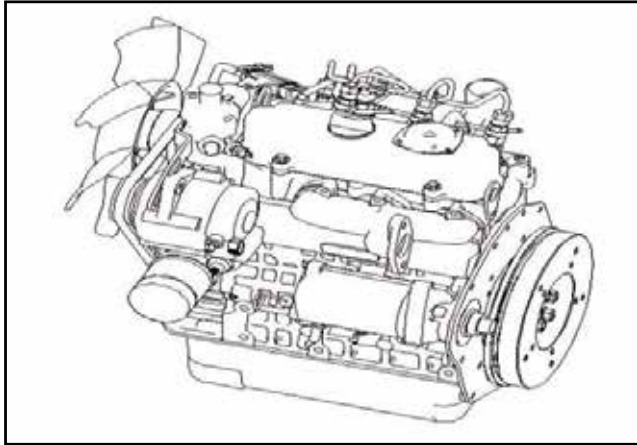

Main Pump

Hydraulic pump is a hydraulic component which converts mechanical energy into liquid pressure energy. It consists of a variable ram pump. Constant power plus load sensitive control mode is adopted.

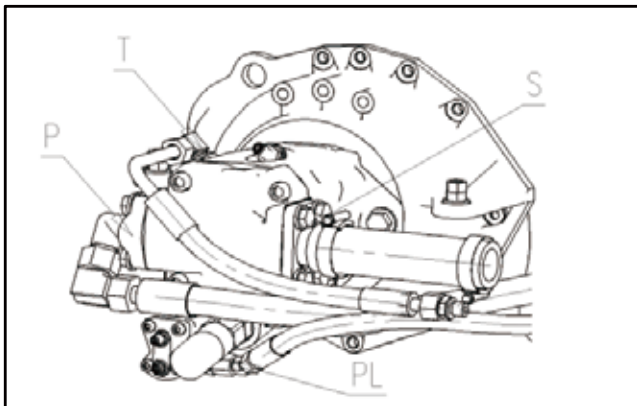

Main Valve

The main valve consists of 11 valve plates. 11 valves including first coupling valve, stick valve, boom valve, bucket valve, spare valve, boom deflection, rotary valve, left travel valve, right travel valve, bulldozing The shovel valve is connected to the end of the valve. (Please refer to the actual product for the specific order).

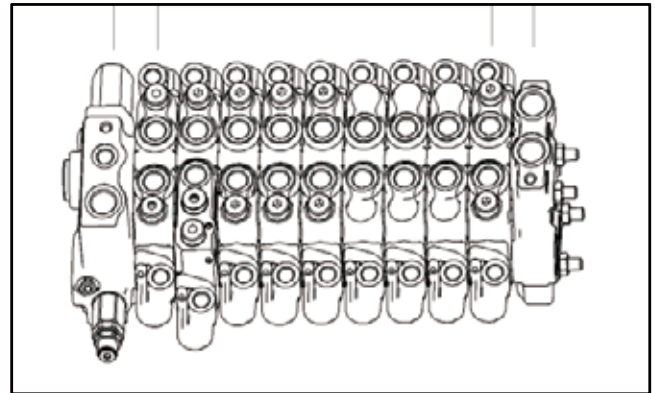

Swing Motor and Reducer

The slewing motor is a orbit motor, including determinant, vanes, drive shafts, relief valves, one-way valves, etc.

This slewing motor has no reducer, and it outputs large torque directly through the drive shaft.

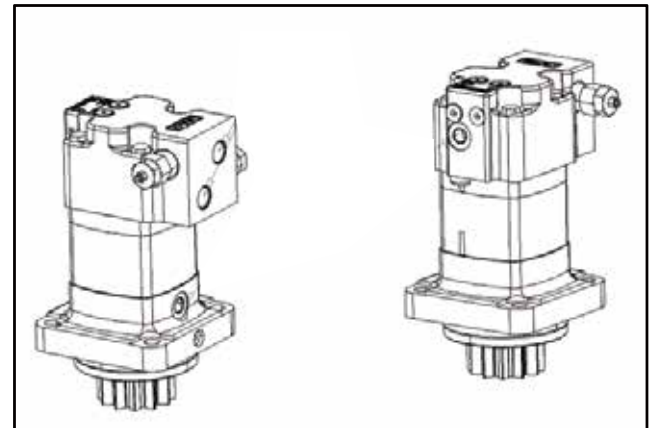

Travel Motor and Reducer

Travel motor and reducer contains the travel motor and the gear reducer. The travel motor is a swash plate axial piston motor that also include plunger, inclined plate, brake valve, balance valve, flow control valve, etc .

The reducer is composed of the sun gear, the planetary gear, the pinion gear and the gear housing.

The high speed and small torque output from the main shaft of the walking motor changes into low speed and large torque after deceleration by the reducer. Two-speed switching can correspond to different working conditions.

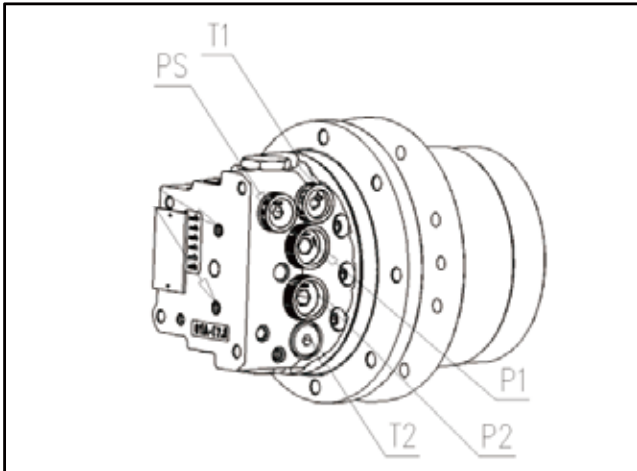

NOTE

If the above description is inconsistent with the products sold, it should be based on the substance delivered, not on this manual as the basis of the product style. If the product style or configuration changes, no notice will be given.

Directions of Machine

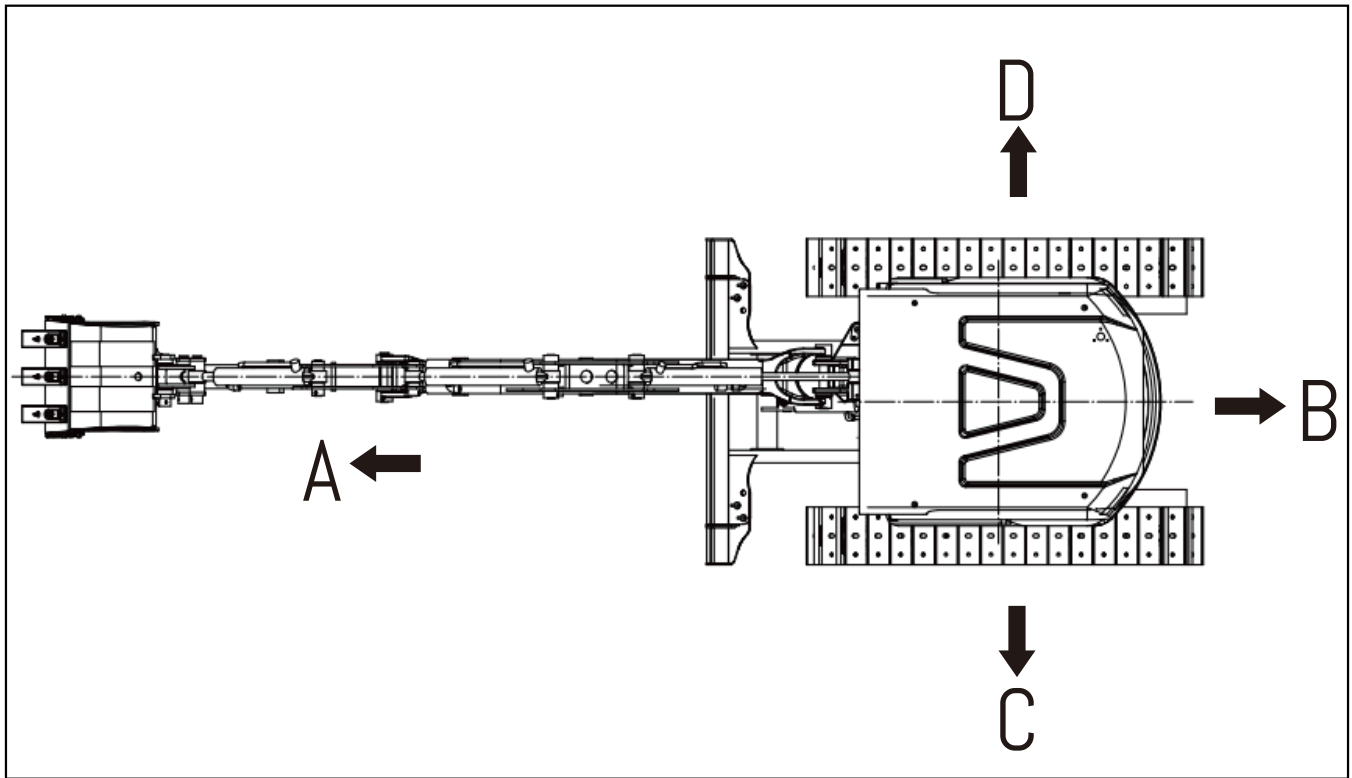

A Front

B Rear

C Left

D Right

In this operator's manual, the state of the machine's traveling direction (front) as seen from the driver's shed is the basic, which determines the front, rear, left, and right of the machine.

Environmental Information Labels and Product Nameplates

The following instructions and words are the product identification and nameplate on the machine.

When you need to maintain the machine or order parts, please inform Mechmaxx Distributor of the following content. Located on the left front side of the rack.

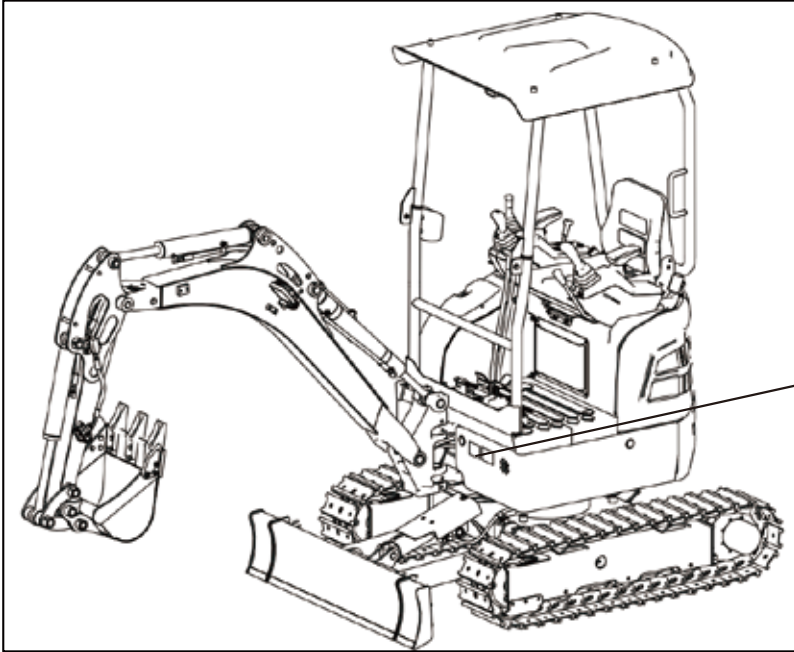

CROBA HYDRAULIC CRAWLER EXCAVATOR	
Model: MEC17	Displacement: 0.898L
Engine: Kubota D902	Year: 2025
Serial No.:	
www.mechmaxx.com	

Engine Number Plate

On the top of the engine cylinder head cover.

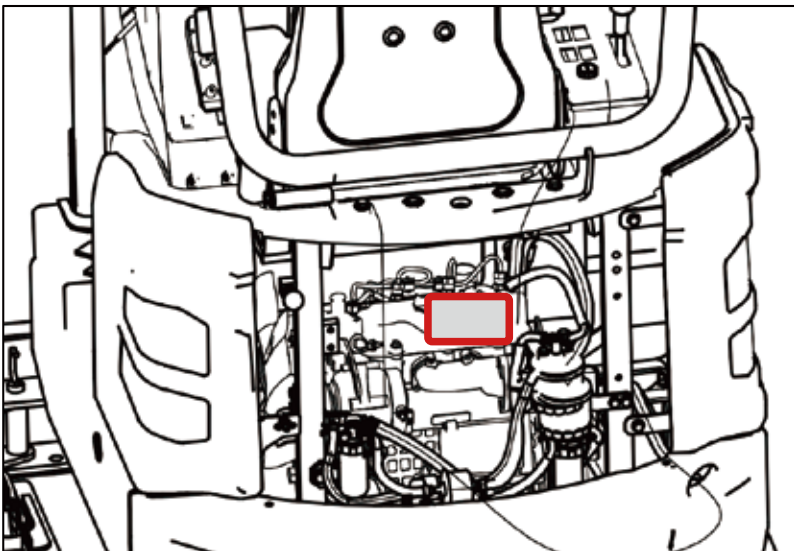

Service Meter Location

The display frame selects the area, and it automatically displays "working time".



SAFETY

WARNING



Please read and make sure that you fully understand the precautions described in this manual and the safety labels on the machine. When operating, maintaining and inspecting the machine, always follow these precautions strictly.

Warning Signs and Illustrations

The following warning, information, and text instructions are used on this machine.

- Be sure that you fully understand the correct position and content of labels.
- To ensure that the content of labels can be read properly, be sure that they are in the correct place and always keep them clean.
- There are also other labels in addition to the warning signs and safety labels. Handle those labels in the same way.
- If the labels are damaged, lost, or cannot be read properly, place an order with Mechmaxx.

Location of Warning Signs and Illustrations

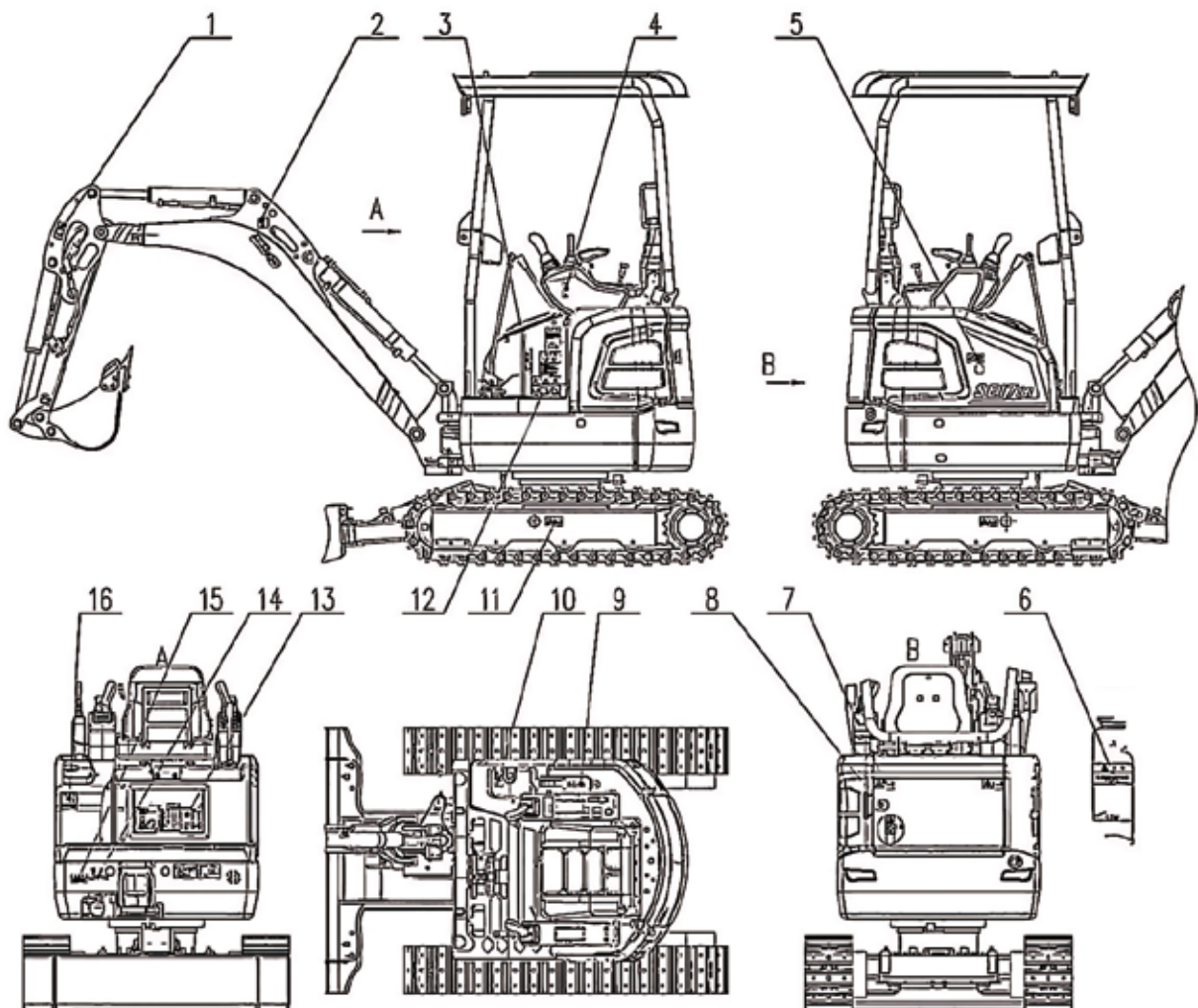

Safety Labels

Beware of work equipment

- Sign indicates a hazard of being hit by the working Device of the machine.
- Keep away from machine during operation.



2. Lifting position sign.

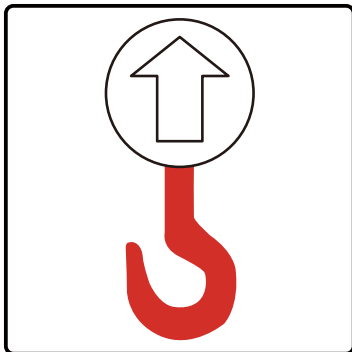

3. Bulldozing and telescopic switch signs.

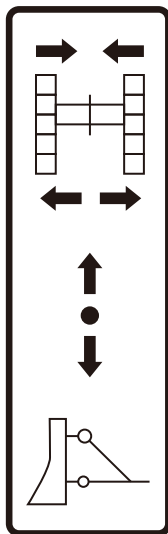

4. Hydraulic oil level check posture sign



5. Coolant pay attention to the label



7. Safety notice sign for turning area

- Do not enter the turning area of the machine when the upper part of the machine is turning.
- There is a danger of collision when the platform rotates.

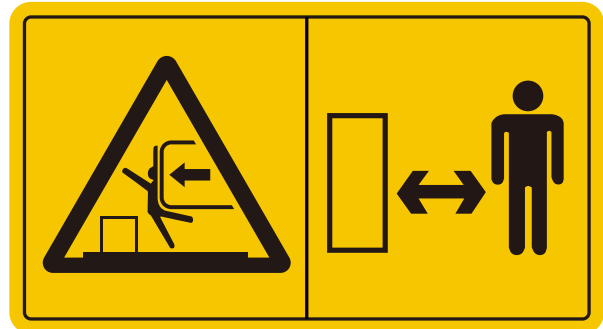

8. Note signs for engine operation

- When the fan is running, it is forbidden to touch or repair it.
- After stopping the operation, perform maintenance.

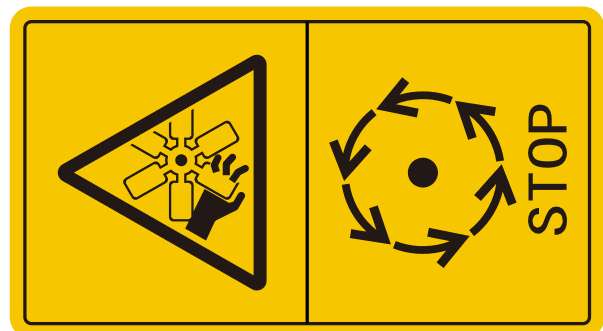

9. Bulldozer and telescopic control sign

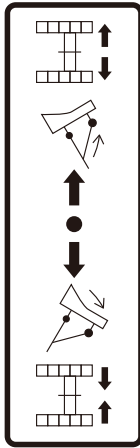

10. Fuel tank cap warning sign

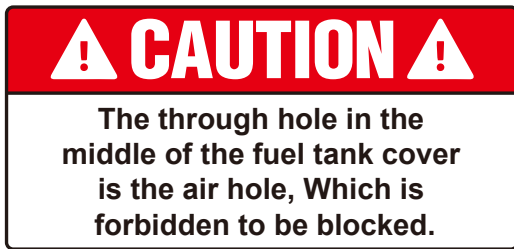

11. Note signs for track adjustment

- The screw plug of the track shoe tension adjustment device will fly out and cause injury.
- When adjusting the track tension, read this driver's manual and follow the correct method.

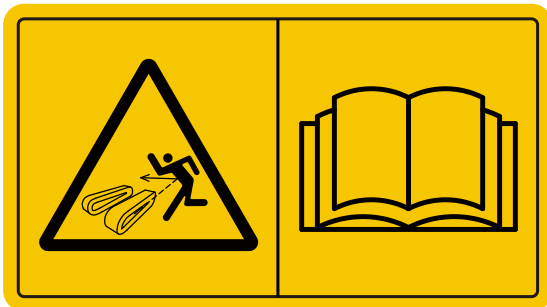

12.

! WARNING !	<p>In order to prevent an accident resulting in injury or death caused by error operation, confirm the machine motion and indicated operating pattern when operating machines, pay attention to the circumference and operate slowly when confirming the machine motion.</p>	ISO MODEL	
--------------------	--	------------------	--

! WARNING !		<p>To prevent severe injury or death, do the following before moving machine or it's attachments:</p> <ul style="list-style-type: none"> • Honk horn to alert people nearby. • Be sure no one is on or near machine or in sawing area. • Rotate cab for full view of travel path if it can be done safely. • Use spotter if view is obstructed. Follow above even if machine equipped with travel alarm and mirrors.
--------------------	--	--



1) Note signs before operation

- Read the driver's manual before operation, maintenance, assembly and transportation



2) Start and stop safety signs

- The sudden movement of the stopped machine may cause the danger of being caught or run over by the machine. When leaving the machine, lower the working device to the ground,
- Move the safety lock lever to the locked position and remove the engine key.



3) High Voltage Attention Sign

- If the machine is close to high-voltage cables, it may cause electric shock to the operator.
- Keep a safe distance between the machine and the cable.

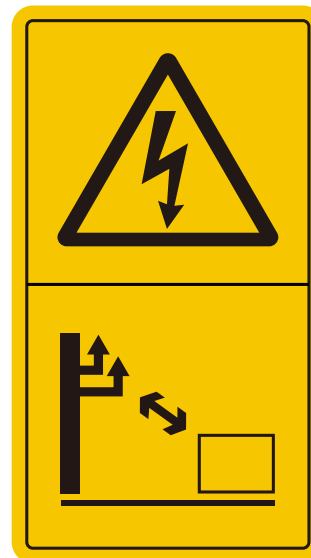

4) Caution signs before reversing.

! WARNING !

To prevent severe injury or death, do the following before moving machine or its attachments:

- Honk horn to alert people nearby.
- Be sure no one is on or near machine or in sawing area.
- Rotate cab for full view of travel path if it can be done safely.
- Use spotter if view is obstructed. Follow above even if machine equipped with travel alarm and mirrors.

5) Caution for operating pattern (ISO mode).

⚠ **WARNING** ⚠

In order to prevent an accident resulting in injury or death caused by error operation, confirm the machine motion and indicated operating pattern when operating machines, pay attention to the circumference and operate slowly when confirming the machine motion.

ISO MODEL

15. Lubrication plate of slewing bearing

⚠ **CAUTION** ⚠

Fill grease every 250 hours
(Don't fill frequently)

16. Dangerous signs for fuel filling

⚠ **WARNING** ⚠

FUEL
DIESEL OIL

Stop the engine when filling the fuel, and keep all the lights and fire in a safe distance.

13. Maintenance and replacement table

MAINTENANCE AND REPLACEMENT CHART		Hours and Intervals							Materials	QTY
No.	Maintenance Items	Every 100h	Initial 100h	Every 250h	Every 500h	Every 1000h	Every 2000h			
		1	Working Device Pins	○						Grease NLG142
2	Slewing Bearing							Grease NLG142		
3	Coilover							MSR Heavy 20000	5/00L	
4	Radiator	○		●				Dishonof Wash		
5	Engine Oil	○	●					API CI-4 SAE 15W-40	3.7L	
6	Engine Oil Filter		●					Filter	1	
7	Fuel	○						EN57-15N	16L	
8	Water & Sediment in Fuel Tank	○								
9	Fuel Fine Filter		●					Fine Filter	1	
10	Fuel Coarse Filter	○								
11	Oil/Water Separator	○								
12	Hydraulic Oil	○						ISO VG46	21.5L	
13	Return Filter			●				Filter	1	
14	Stacker Filter					○		Filter	1	
15	Travel Drive							API CI-4 SAE 88W-90	245.3L	
16	Air Filter	○						Main Filter Safety Filter	Each	
17	Post Filter							Filter	1	

NOTICE: 1. Stop engine for maintenance and replacement. 2. Please refer to the Operator's Manual for other details.

14. Filling position signs

GREASE INJECTION POINT

●
Swing bearing

●
Swing gear

Basic Safety Information

Safety Rules

- Only trained and authorized personnel can operate and maintain the machine.
- Follow all safety rules, precautions and instructions when operating or performing maintenance on the machine.
- Do not operate the machine if you are in poor physical condition and mental instability, under the influence of drugs (easily drowsy) or alcohol.
- When working with another operator or configuring a signal person, be sure that all personnel understand all hand signals that are to be used.

If Problems are Found

If you find any problems in the machine during operation or maintenance (noise, vibration, smell, incorrect gauges, smoke, oil leakage, etc., or any abnormal display on the warning devices or monitor), report to the person in charge and have the necessary action taken. Do not operate the machine until the problem has been corrected.

Working Wear and Personal Protective Items

- Do not wear loose clothing and accessories. There is a hazard that they may catch on control levers or other protruding parts.
- If you have long hair and it hangs out from your hard hat, there is a hazard that it may get caught up in the machine, so tie your hair up and be careful not to let it get caught.
- Always wear a hard hat and safety shoes. If the nature of the work requires it, wear safety glasses, mask, gloves, ear plugs, and safety belt when operating or maintaining the machine.
- Check that all protective equipment functions properly before using it.



Fire Extinguisher and First Aid Kit

Always follow the precautions below to prepare for action if any injury or fire should occur.

- Be sure that fire extinguishers have been provided and ensure that you know their use well in emergencies.
- Carry out periodic inspection and maintenance to ensure that the fire extinguisher can always be used.
- Provide a first aid kit in the storage point. Carry out periodic checks and add to the contents if necessary.



Safety Equipment

- Be sure that all guards, covers and rear view mirror are in their proper position. Have guards and covers repaired immediately if they are damaged.
- Understand the method of use of safety features and use them properly.
- Never remove any safety features. Always keep them in good operating condition.

Keep Machine Clean

- If water gets into the electrical system, there is a hazard that it will cause malfunctions or misoperation. Do not use water or steam to wash the electrical system (sensors, alternators, solenoid valves, connectors).
- If inspection and maintenance is carried out when the machine is still dirty with mud or oil, there is a hazard that you will slip and fall, or that dirt or mud will get into your eyes. Always keep the machine clean.



WARNING



When cleaning the engine around, the following two can not be cleaned and splashed liquid, otherwise it will cause damage of engine parts.

1. Generator; 2. Starting motor

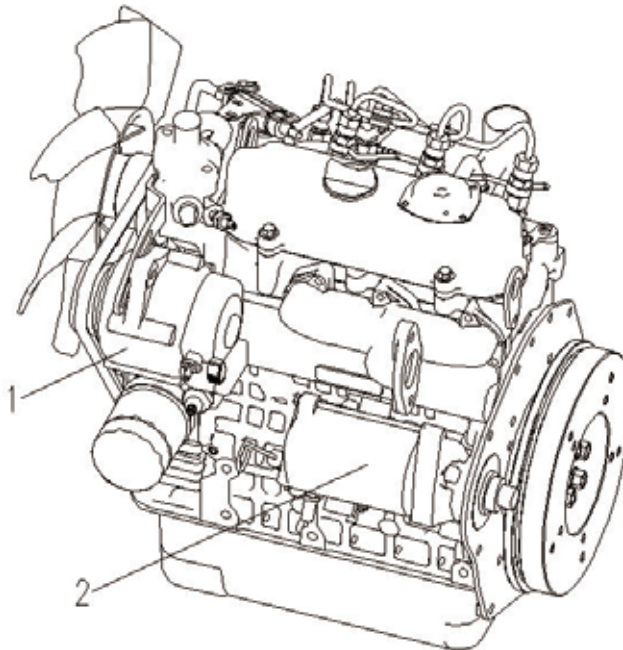

Precautions of Standing up or Leaving from the Operator's Seat

- Before standing up from the seat (for example, when adjusting the seat, etc.), lower the working device to the ground completely. At the same time, move the lock lever to the locked position, and then turn off the engine. If you accidentally touch the unlocked joystick, the machine may move suddenly and cause a serious personal accident.
- When leaving the machine, you must lower the working device and the bulldozer to the ground, place the lock lever in the locked position, and stop the engine. In addition, lock all equipment with a key. Take down the key and put it in the specified position.

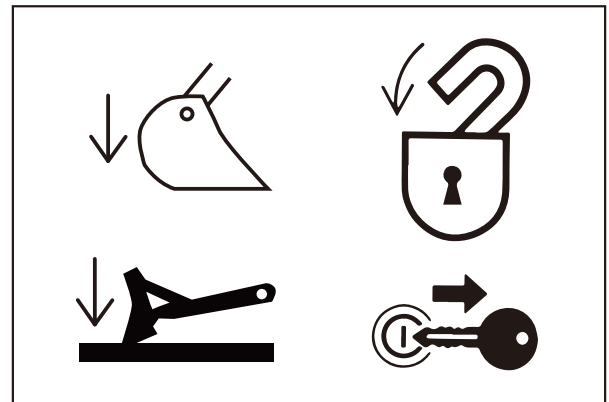

Use Handrails and Stairs Leaving Operator's Seat

To prevent personal injury caused by slipping or falling off the machine, always do as follows:

- To ensure safety, always face the machine and maintain three-point contact (both feet and one hand, or both hands and one foot) with the handrails and steps (including the track shoe) to ensure that you support yourself.
- Do not grip the control levers or lock lever when getting on or off the machine.
- Never climb on the engine hood or cover that does not have anti-skid devices.
- Before getting on or off the machine, check the handrails and steps (including the track shoe). If there is any oil, grease, or mud on the handrails or steps (including the track shoe), wipe it off immediately. Always keep these parts clean. Repair any damage and tighten any loose bolts.
- Do not get on or off the machine while holding tools in your hands.

Forbidden to Jump On or Off the Machine

- Never jump on or off the machine. Never get on or off a moving machine.
- If the machine starts to move when there is no operator on the machine, do not jump on to the machine and try to stop it.

No Persons on Attachments

Never let anyone ride on the work equipment, or other attachments. There is a hazard of falling and suffering serious injury.

Not to Be Pinched

Due to the action of the connecting rod, the peripheral clearance of the working device will change. If caught, it may cause a serious personal accident. Personnel are not allowed to approach all rotating and telescopic parts.

Burn Prevention

Due to the action of the connecting rod, the peripheral clearance of the working device will change. If caught, it may cause a serious personal accident. Personnel are not allowed to approach all rotating and telescopic parts.

Hot coolant

- To prevent burns from hot water or steam spurting out when checking or draining the coolant, wait for the water to cool to a temperature where it is possible to touch the radiator cap by hand before starting the operation. Even when the coolant has cooled down, loosen the cap slowly to relieve the pressure inside the radiator before removing the cap.



Hot oil

- To prevent burns from hot oil spurting out when checking or draining the oil, wait for the oil to cool to a temperature where it is possible to touch the cap or plug by hand before starting the operation. Even when the oil has cooled down, loosen the cap or plug slowly to relieve the internal pressure before removing the cap or plug.



Fire prevention and Explosion Prevention Fire caused by fuel or oil.

Fuel, oil, antifreeze, and window washer liquid are particularly flammable and can be hazardous. To prevent fire, always observe the following:

- Do not smoke or use any flame near fuel or oil.
- Stop the engine before refueling.
- Do not leave the machine while adding fuel or oil.
- Tighten all fuel and oil caps securely.
- Do not spill fuel on overheated surfaces or on parts of the electrical system.
- Use well-ventilated areas for adding or storing oil and fuel.
- Keep oil and fuel in the determined place and do not allow unauthorized persons to enter.
- After adding fuel or oil, wipe up any spilled fuel or oil.
- When carrying out grinding or welding work on the machine, move any flammable materials to a safe place before starting.
- When washing parts with oil, use a non-flammable oil. Diesel oil and gasoline may catch fire, so do not use them.
- Put greasy rags and other flammable materials into a safe container to maintain safety at the work place.
- Do not weld or use a cutting torch to cut any pipes or tubes that contain flammable liquids.

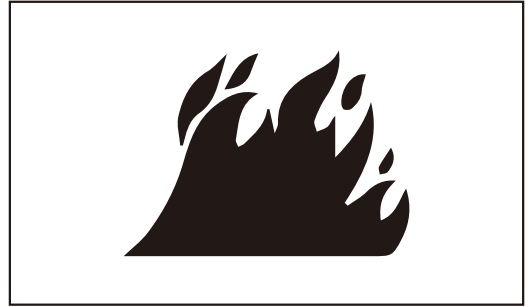

Fire Caused by Accumulation of Flammable Material.

Remove any dry leaves, chips, pieces of paper, dust, or any other flammable materials accumulated or affixed around the engine, exhaust manifold, muffler, or battery, or inside of the machine.

Fire coming from electric wiring

Short circuits in the electrical system can cause fire.

- Always keep electric wiring connections clean and securely tightened.
- Check the wiring every day for looseness or damage. Tighten any loose connectors or wiring clamps. Repair or replace any damaged wiring.

Fire caused by piping

Check that all hoses and pipe clamps, shields and cushions are firmly fixed in place. If loosened, vibration and friction with other parts will occur during operation, resulting in damage to hoses, high-pressure oil ejection, fire hazards or personal accidents.

Explosion Caused by Lighting Equipment

- When checking fuel, oil, battery electrolyte, window washer fluid, or coolant, always use lighting with anti-explosion specifications. If such lighting equipment is not used, there is danger of explosion that may cause serious injury.
- When taking the electrical power for the lighting from the machine itself, follow the instructions in this manual.

Action in Case of Fire

If fire occurs, escape from the machine as follows.

- Turn the start switch OFF to stop the engine.
- Use the handrails and steps to get off the machine.

Falling Objects, Flying Objects and Intruding Objects Prevention

- On jobsite there is a hazard that falling objects, flying objects, or intruding objects may hit or enter the operator's cab, consider the operating conditions and install the necessary guards to protect the operator.
- When carrying out demolition or breaker operation, install a front guard and use a laminated coating sheet on the front.
- When working in mines or quarries where there is a hazard of falling rock, install FOPS (Falling Objects Protective Structure) and a front guard, and use a laminated coating sheet on the front glass.
- When carrying out the above operations, always close the front window. In addition, always ensure that standers-by are a safe distance away and are not in hazard from falling or flying objects.
- The above recommendations assume that the conditions are for standard operations, but it may be necessary to add additional guards according to the operating conditions on the jobsite. Always contact your Mechmaxx distributor for advice.



Attachment Installation

- When installing optional parts or attachments, there may be problems with safety or legal restrictions. Therefore contact your mechmaxx distributor for advice.
- Any injuries, accidents, or product failures resulting from the use of unauthorized attachments or parts will not be the responsibility of mechmaxx.
- When installing and using optional attachments, read the instruction manual for the attachment, and the general information related to attachments in this manual.

Attachment Combinations

Depending on the type or combination of work equipment, there is a hazard that the work equipment may hit the driving shed or other parts of the machine.

Before using unfamiliar work equipment, check if there is any hazard of interference, and operate with caution.

Unauthorized modifications

- Any modification made without authorization from Mechmaxx may create hazards.
- Before making any changes, consult your authorized Mechmaxx distributor.
- Mechmaxx is not responsible for injuries, accidents, product failures, or property damage resulting from unauthorized modifications.

Safety on the Job site

Before starting operations, thoroughly check the area for any unusual conditions that could be dangerous.

- When carrying out operations near combustible materials such as thatched roofs, dry leaves or dry grass, there is a hazard of fire, so be careful when operating.
- Check the terrain and condition of the ground at the jobsite, and determine the safest method of operation. Do not operate where there is a hazard of landslides or falling rocks.
- If water lines, gas lines, or high-voltage electrical lines may be buried under the job site, contact each utility and identify their locations. Be careful not to sever or damage any of these lines.

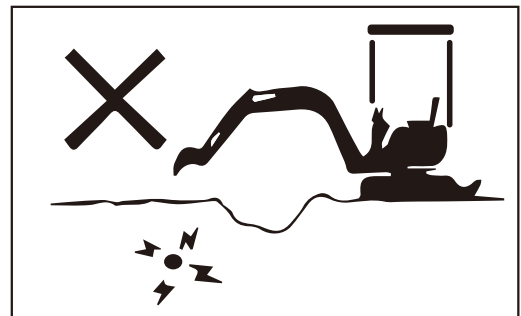

- Take action to prevent unauthorized people from approaching the job site. When working on public roads, position flagmen and erect barriers to ensure the safety of passing traffic and pedestrians.
- When traveling or operating in shallow water or on soft ground, check the shape and condition of the bedrock, and the depth and speed of flow of the water before starting operations.

Prevent the machine tipping over

- Avoid traveling or operating your machine too close to the edge of cliffs, overhangs, and deep ditches. The ground may be weak in such areas. If the ground should collapse under the weight or vibration of the machine, there is a hazard that the machine may fall or tip over. Remember that the soil after heavy rain or blasting or after earthquakes is weak in these areas.
- When working on embankments or near excavated ditches, there is a hazard that the weight and vibration of the machine will cause the soil to collapse. Before starting operations, take steps to ensure that the ground is safe and to prevent the machine from rolling over or falling.

Distance to High Voltage Cables

Do not travel or operate the machine near electric cables. There is a hazard of electric shock, which may cause serious injury or property damage. On jobsites where the machine may go close to electric cables, always do as follows.

- Before starting work near electric cables, inform the local power company of the work to be performed, and ask them to take the necessary action.
- Even going close to high-voltage cables can cause electric shock. Always maintain a safe distance (see the table) between the machine and the electric cable. Check with the local power company about safe operating procedure before starting operations.
- To prepare for any possible emergencies, wear rubber shoes and gloves. Lay a rubber sheet on top of the seat, and be careful not to touch the chassis with any exposed part of your body.
- Use a signalman to give warning if the machine approaches too close to the electric cables.
- When carrying out operations near high voltage cables, do not let anyone near the machine.
- If the machine should come too close or touch the electric cable, to prevent electric shock, the operator should not leave the operator's compartment until it has been confirmed that the electricity has been shut off. Also, do not let anyone near the machine.

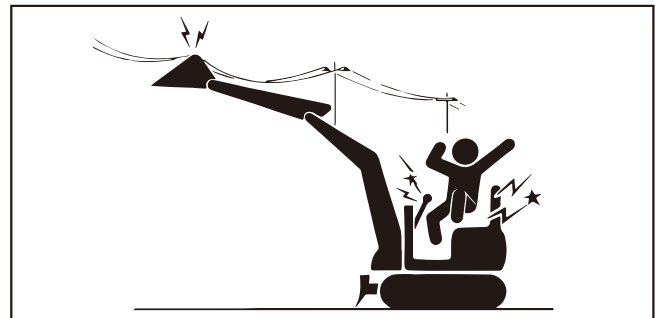

	Voltage of Cables	Safety Distance
Low voltage	100 V-200 V	Over 2 m (7 ft)
	6600 V	Over 2 m (7 ft)
Extra high voltage	22000 V	Over 3 m (10 ft)
	66000 V	Over 4 m (14 ft)
	154000 V	Over 5 m (17 ft)
	187000 V	Over 6 m (20 ft)
	275000 V	Over 7 m (23 ft)
	500000 V	Over 11 m (36 ft)

Ensure Good Visibility

Check for any persons or obstacles in the area around the machine and check the conditions of the job site to ensure that operations and travel can be carried out safely. Always do as follows.

- When working in dark places, turn on the working lamp and front lamps installed to the machine, and set up additional lighting in the work area if necessary.
- Stop operations if the visibility is poor, such as in mist, snow, rain, or dust.

Ventilation for Enclosed Area

If it is necessary to start the engine within an enclosed area, or when handling fuel, flushing oil, or paint, open the doors and windows to ensure that adequate ventilation is provided to prevent gas poisoning.

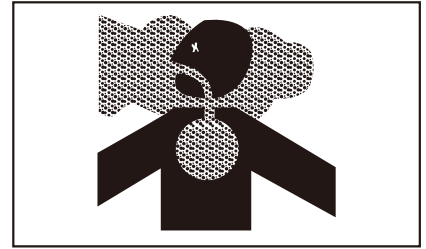

Signalman's Signal and Signs

- Set up signs to inform of road shoulders and soft ground. If the visibility is not good, position a signalman if necessary. Operators should pay careful attention to the signs and follow the instructions from the signalman.
- Only one signalman should give signals.
- Make sure that all workers understand the meaning of all signals and signs before starting work.

Asbestos Dust Hazard Prevention

Asbestos dust in the air can cause lung cancer if it is inhaled. There is danger of inhaling asbestos when working on job sites handling demolition work or work handling industrial waste. Always observe the following.

- Spray water to keep down the dust when cleaning. Do not use compressed air for cleaning.
- If there is danger that there may be asbestos dust in the air, always operate the machine from an upwind position. All workers should use an approved respirator.
- All personnel should use dust masks.
- Do not allow other persons to approach during the operation.
- Always observe the rules and regulations for the work site and environmental standards.
- This machine does not use asbestos, but there is a danger that imitation parts may contain asbestos, so always use genuine mechmaxx parts.

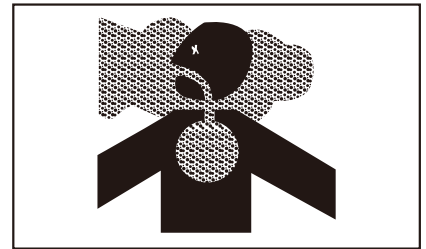

Safety Machine Operation

Starting Engine

If there is a warning tag hanging from the work equipment control lever, do not start the engine or touch the levers .

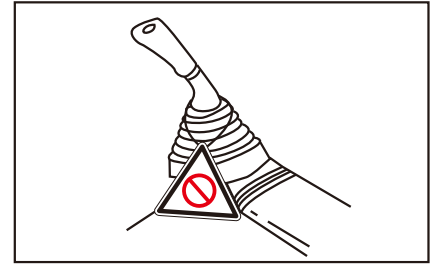

Checks before Starting Engine

Carry out the following checks before starting the engine at the beginning of the day's work.

- Remove all dirt from the surface of the window glass to ensure a good view.
- Remove all dirt from the surface of the lens of the working lamps, and check that they light up correctly.
- Check the coolant level, fuel level, and oil level in engine oil pan, check for clogging of the air cleaner, and check for damage to the electric wiring.
- Adjust the operator's seat to a position where it is easy to carry out operations, and check that there is no damage or wear to the seat belt or mounting clamps.
- Check the operation of the instruments and gauges, check the angle of the mirror, and check that the control levers are all at the Neutral position.
- Before starting the engine, check that lock lever is in LOCK position.
- Check that there are no persons or obstacles above, below, or in the area around the machine.

Safety rules for Starting Engine

- Start and operate the machine only while seated.
- Do not attempt to start the engine by short-circuiting the engine starting circuit. Such an act may cause a serious bodily injury or fire.
- When starting the engine, sound the speaking as a warning.
- Do not allow anyone apart from the operator to ride on the machine.

Starting Engine in Cold Weather

- Carry out the warming-up operation thoroughly. If the machine is not thoroughly warmed up before the control levers or control pedals are operated, the reaction of the machine will be slow or the machine may move in a way not expected by the operator.
- If the battery electrolyte is frozen, do not charge the battery or start the engine with a different power source. There is a hazard that this will ignite the battery and cause the battery to explode.
- Before charging or starting the engine with a different power source, melt the battery electrolyte and check that there is no leakage of electrolyte before starting.

Operation

Checks before Operation

When carrying out the checks, move the machine to a wide area where there are no obstructions, and operate slowly. Do not allow anyone near the machine.

- Always fasten your seat belt.
- Check that the movement of the machine matches the display on the control pattern card. If it does not match, replace it immediately with the correct control pattern card.
- Check the operation of the gauges and equipment, and check the operation of the bucket, arm, boom, travel system, swing system, and steering system.
- Check for any problem in the sound of the machine, vibration, heat, smell, or gauges; check that whether there is leakage of oil or fuel or not.
- If any problem is found, carry out repairs immediately.

Safety Rules for Changing Machine Directions

Before traveling, set the machine so that sprocket ① is behind the operator's seat. If sprocket ① is in front of the operator's seat, the machine is in the opposite direction from the operation of the lever (front and rear travel is reversed, left and right steering is reversed). Be extremely careful when operating the machine in this situation.

- Before traveling, check again that there is no one in the surrounding area, and that there are no obstacles.
- Before traveling, sound the speaker to warn people in the area.
- Always operate the machine only when seated.
- Do not allow anyone apart from the operator to ride on the machine.
- If there is an area to the rear of the machine which cannot be seen, position a signal person. Take special care so as not to hit other machines or people when turning or swinging the machine.
- Check that the travel alarm (optional) works properly.

Always be sure to carry out the above precautions even when the machine is equipped with mirrors.

Safety Rules for Traveling

- Do not operate the machine at excessive speed, or start, stop, or turn suddenly.
- On flat ground, keep the work equipment 1.57–1.97 in (40–50 mm) above the ground.
- On rough ground, travel slowly and avoid sudden steering. Sudden movements may cause the machine to tip over, strike the ground, or damage nearby structures.
- Avoid traveling over obstacles whenever possible. If crossing is unavoidable, keep the work

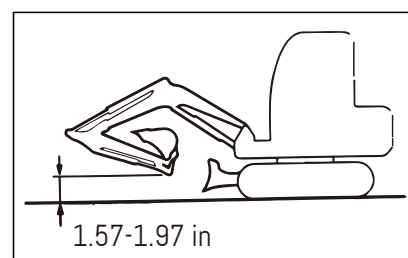
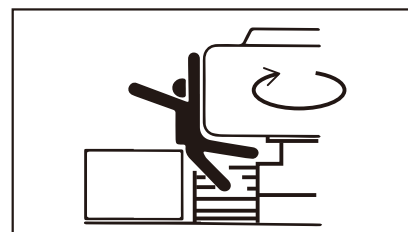
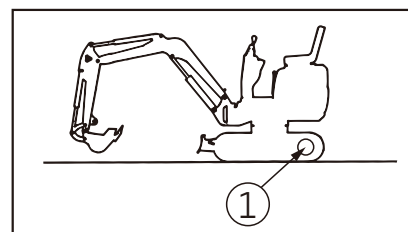

Operations on Slopes

- When working on slopes, there is a hazard that the machine may lose its balance and turn over when the swing or work equipment are operated. This may lead to serious injury or property damage, so always provide a stable place when carrying out these operations, and operate carefully.
- Do not swing the work equipment from the uphill side to the downhill side when the bucket is loaded. This operation is dangerous, and may cause the machine to tip over.
- If the machine has to be used on a slope, pile the soil to make a platform (A) that will keep the machine as horizontal as possible.

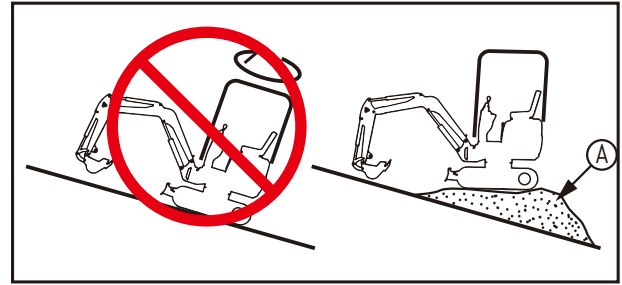

Prohibited Operations

- Never dig the work face under an overhang. There is a hazard that rocks may fall or that the overhang may collapse and fall on top of the machine.
- Do not excavate too deeply under the front of the machine. The ground under the machine may collapse and cause the machine to fall.
- To make it easier to escape if there is any problem, set the tracks at right angles to the road shoulder or cliff with the sprocket at the rear when carrying out operations.
- Do not carry out demolition work under the machine. There is a hazard that the machine may become unstable and tip over.
- When working on or from the top of buildings or other structures, check the strength and the structure before starting operations. There is a hazard of the building collapsing and causing serious injury or damage.
- When carrying out demolition work, do not carry out demolition above your head. There is a hazard of broken parts falling or of the building collapsing and causing serious injury or property damage.
- Do not use the impact force of the work equipment for breaking work. There is a hazard of damage to the work equipment, or a hazard of serious personal injury being caused by flying pieces of broken materials, or of the machine tipping over due to reaction from the impact.
- Generally speaking, the machine is more liable to overturn when the work equipment is at the side than when it is at the front or rear.
- When using a breaker or other heavy work equipment, there is a hazard of the machine losing its balance and tipping over. When operating on flat ground as well as on slopes.
- Do not suddenly lower, swing, or stop the work equipment.
- Do not suddenly extend or retract the boom cylinder. There is a hazard that impact will cause the machine to tip over.
- Do not pass the bucket over the head of other workers or over the operator's seat of dump trucks or other hauling equipment. The load may spill or the bucket may hit the dump truck and cause serious injury or property damage.

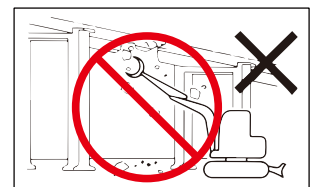
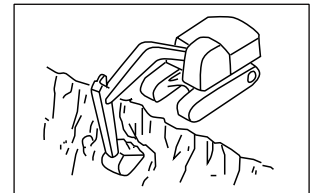

- When traveling or carrying out operations, always keep a safe distance from people, structures, or other machines to avoid coming into contact with them.
- When crossing bridges or structures, first confirm that they are strong enough to support the machine's weight.
- When traveling on public roads or highways, contact the relevant authorities in advance and follow their instructions.
- When operating in tunnels, under bridges, under electric wires, or other places where the height is limited, operate slowly and be extremely careful not to let the work equipment hit anything.
- Do not let the machine or working device touch anything.

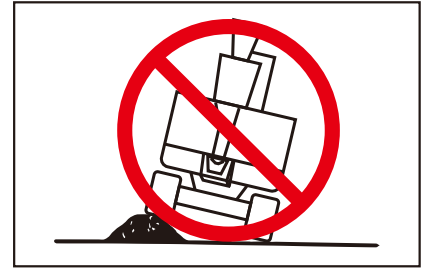

Traveling on Slopes

To prevent the machine from tipping over or slipping to the side, always do as follows.

- Keep the work equipment approx. 0.7 to 1.1 in above the ground. In case of emergency, lower the work equipment to the ground immediately to help stop the machine.
- When traveling up slopes, set the driver's shed facing uphill, when travel down slopes, set the driver's shed facing downhill. Always check the firmness of the ground under the front of the machine when traveling.
- When traveling up a steep slope, extend the work equipment to the front to improve the balance, keep the work equipment approximately 0.7 to 1.1 in above the ground, and travel at low speed.
- When traveling downhill, lower the engine speed, keep the travel lever close to the neutral position, and travel at low speed. When walking downhill on a slope with a slope of 15° or more, as shown in the right figure, place the driving wheel ① on the downhill side, reduce the engine speed and walk.
- Always travel straight up or down a slope. Traveling at an angle or across the slope is extremely dangerous.
- Do not turn on slopes or travel across slopes. Always go down to a flat place to change the position of the machine, then travel on to the slope again.
- Travel on grass, fallen leaves, or wet steel plates with low speed. Even with slight slopes there is a hazard that the machine may slip.
- If the engine stops when the machine is traveling on a slope, move the control levers immediately to the neutral position and start the engine again.

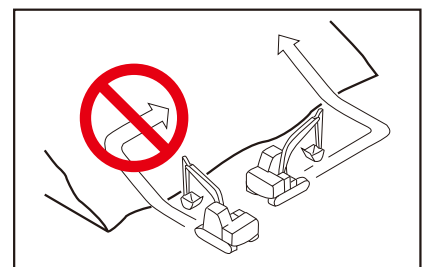
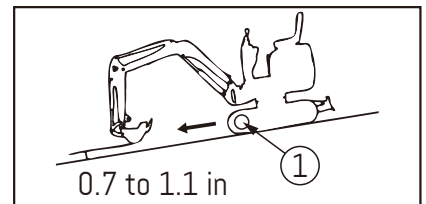
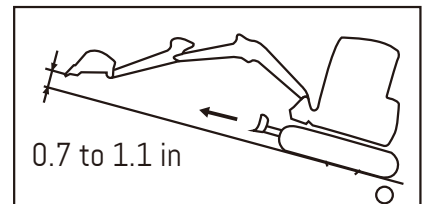
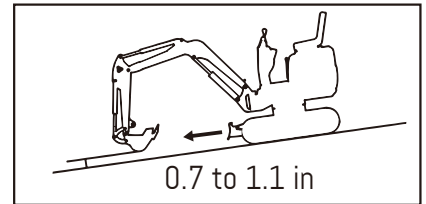
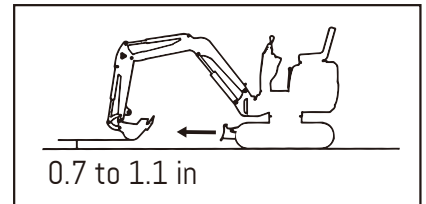

Operations on Snow

- Snow-covered or frozen surfaces are slippery, so be extremely careful when traveling or operating the machine, and do not operate the levers suddenly. Even a slight slope may cause the machine to slip, so be particularly careful when working on slopes.
- With frozen ground surfaces, the ground becomes soft when the temperature rises, and this may cause the machine to tip over.
- If the machine enters deep snow, there is a hazard that it may tip over or become buried in the snow. Be careful not to leave the road shoulder or to get trapped in a snow drift.
- When clearing snow, the road shoulder and objects placed beside the road are buried in the snow and cannot be seen. There is a hazard of the machine tipping over or hitting covered objects, so always carry out operations carefully.

Parking Machine

- Park the machine on firm, level ground.
 - Select a place where there is no hazard of falling rocks or landslides, or of flooding if the land is low.
 - Lower the work equipment completely to the ground.
-
- When leaving the machine, set lock lever to the LOCK position, then stop the engine.
 - Always close the operator's cab door, and use the key to lock all the equipment in order to prevent any unauthorized person from moving the machine. Always remove the key, take it with you, and leave it in the specified place.
-
- If it is necessary to park the machine on a slope, always do as follows.
 - Set the bucket on the downhill side, then dig it into the ground.
 - Put blocks under the tracks to prevent the machine from moving.

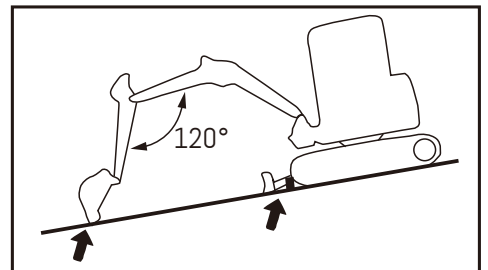
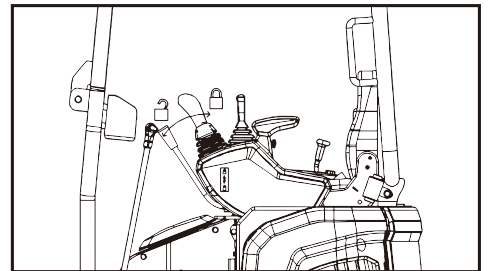
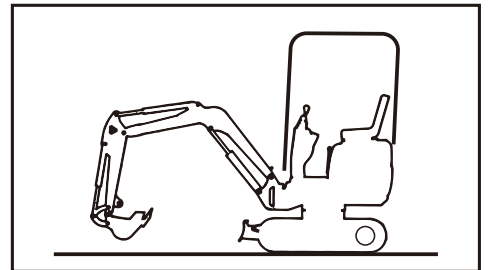

Transport

Loading and Unloading

When loading or unloading the machine, mistaken operation may bring the hazard of the machine tipping over or falling, so particular care is necessary. Always do as follows.

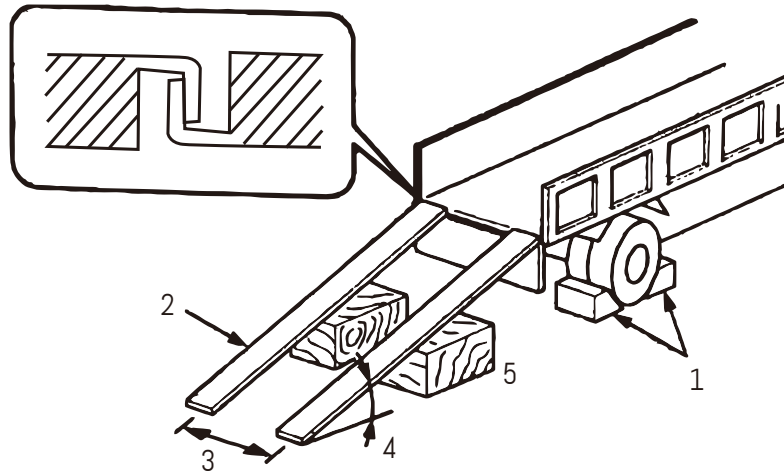

①Stoppers ②Ramp ③Spacing of ramp ④The ramp angle is under 15° ⑤Blocks

- Choose a solid and flat ground and keep a safe distance from the shoulders and edges of the road. Never use working devices to load and unload machines. Otherwise, there is a danger of the machine tipping or falling.
- Always use ramps of adequate strength. Be sure that the ramps are wide, long, and thick enough to provide a safe loading slope. Take suitable steps to prevent the ramps from moving out of position or coming off. Be sure the ramp surface is clean and free of grease, oil, ice and loose materials. Remove dirt from machine-tracks. On a rainy day, in particular, be extremely careful since the ramp surface is slippery.
- Run the engine at low speed and travel slowly.
- Never correct your steering on the ramps. If necessary, drive off the ramps, correct the direction, then enter the ramps again.
- When on the ramps, do not operate any lever except for the travel lever.
- The center of gravity of the machine will change suddenly at the joint between the ramps and the track or trailer, and there is danger of the machine losing its balance. Travel slowly over this point.
- When loading or unloading to an embankment or platform, make sure that it has suitable width, strength, and grade.
- When swinging the upper structure on the trailer, the trailer is unstable, so pull in the work equipment and swing slowly.
- Refer to "Transportation".

Shipping the Machine

When transporting the machine on a trailer, follow these instructions:

- The machine's weight, transport height, and overall length vary depending on the work equipment installed. Always confirm the actual dimensions before transport.
- When crossing bridges or structures on private property, first ensure that they are strong enough to support the machine's weight.
- When traveling on public roads, consult the relevant authorities in advance and follow their instructions.
- For detailed transport procedures, refer to the "Transportation" section.

Battery

Put the Battery cut-off Switch OFF (closed)

For the following occasions, puts starting switch OFF (closed) position, put the battery cut-off switch OFF (closed) position. Otherwise may cause electric shock and other major accidents.

- Long term storage machine (more than one month);
- When repairing the electrical system;
- When welding;
- When handling the battery;
- When replacing fuses and other parts.

Battery Safety Operation

Electricity

- When battery positive and negative electrodes on both ends of a column by metal conductor (such as: metal tools, metal wire, metal parts, etc.) accident nipple, namely external battery short circuit, can produce arc melting polar column, and cause the molten lead alloy splash, serious when the combustion caused a lot of heat.
- Prevention: battery assembly fault diagnosis using metal tools or use metal wire, avoid direct short circuit battery is negative column.
- Protection: wear protective glasses and gloves.
- Emergency treatment: when burning, use live wrench or other tools, external short-circuit metal conductor, immediately disconnect the battery don't contact with, and use the extinguishing fire materials.

Sulfuric Acid

- Filling battery or a battery charging, resulting in shell burst, from sulphuric acid may break out or spills.
- Prevention: careful handling. Vertical placement; According to the supplementary electrical program to supplement the electricity.
- Protection: wear protective glasses and acid proof clothes.
- Emergency treatment: when skin contact with sulfuric acid, immediately flush skin with plenty of clean flowing water surface, and remove contaminated clothes; When the eyes contact with sulfuric acid, rinse immediately with clean water for at least 10 minutes; When due to accidentally splashed acid in the mouth, can drink lots of water or milk. To find a doctor when necessary.

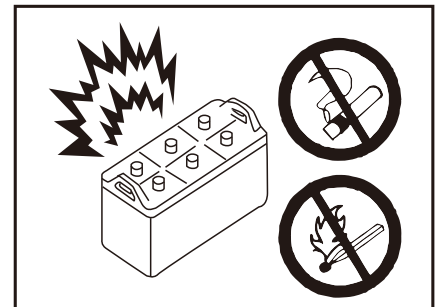

Emissions of Gases

- In rechargeable battery, test process, the mixture of hydrogen and oxygen from the induction in vent. If more than 4% hydrogen concentration in the environment, have open flame, sparks or high fever will be an explosion.
- Prevention: charging keep ventilation. Smoking is prohibited, to prevent sparks and open flame. Battery wire connection order: first the positive line connection, after connect the cathode lines; Disconnect the battery cable order: first to disconnect the battery negative electrode wire, and then disconnect the battery positive electrode line.
- Protection: wear protective glasses and acid proof clothes.
- Emergency treatment: battery burst, a large number of spills, sulfate operator should immediately flush sulfuric acid splash down; When necessary, will be ablation of sulfate personnel immediately to a hospital treatment.

Additional Electric Battery

Before cars started, the car with electric start time is too long and abnormal use, because of leakage and long car stops, the vehicle or the vehicle charging generator failure, the battery can't normal charging battery loss caused by electricity, battery electric eye blackened, even can't start the car. The battery need to supplement by electricity.

Check that the open circuit voltage of the battery terminal is lower than 12.45V, and the battery should be supplemented immediately.

When charging the battery we must know

- Wearing glasses.
- Maintain environmental ventilation when charging, charging under normal temperature.
- No smoking when charging, and to avoid the introduction of the flame.
- After charging connection, first connect the positive attachment; Take out stitches before charging, disconnect the cathode attachment first.

Battery supplement electricity at action part "Battery Discharges and Charges".

Starting Engine with Booster Cables

If any mistake is made in the method of connecting the booster cables, it may cause the battery to explode, so always do as follows.

- When starting with a booster cable, carry out the starting operation with two workers (one worker sitting in the operator's seat and the other working with the battery).
- When starting from another machine, do not allow the two machines to touch.
- When connecting the booster cables, turn the starting switch OFF for both the normal machine and problem machine. There is a hazard that the machine will move when the power is connected.
- Be sure to connect the positive (+) cable first when installing the booster cables. Disconnect the negative (-) cable (ground side) first when removing them.
- When connecting the auxiliary cable, set the start switch of the faulty machine, the battery disconnect switch and the start switch of the normal machine to the OFF (closed) position. For details, please refer to the item "Battery disconnect switch". When the power is connected, the machine may start and cause danger.
- When removing the booster cables, be careful not to let the booster cable clips touch each other or to let the clips touch the machine.
- Always wear safety goggles and rubber gloves when starting the engine with booster cables.
- When connecting a normal machine to a problem machine with booster cables, always use a normal machine with the same battery voltage as the problem machine.
- For details of the starting procedure when using booster cables, see "Starting Engine with Booster Cables" in the OPERATION section.

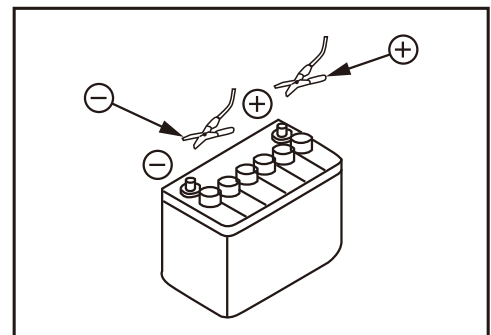
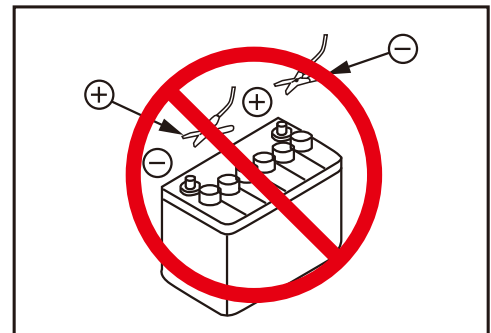

Towing and Being Towed

Safety Rules for Towing and Being Towed

Serious injury or death could result if a disabled machine is towed incorrectly or if there is a mistake in the selection or inspection of the wire rope. For towing, see "Towing the Machine" in the OPERATION section.

- Always wear leather gloves when handling wire rope.
- Fix the wire rope to the frame of the crawler frame (allow two holes at A for traction)
- During the towing operation, never stand between the towing machine and the machine being towed.
- Never tow a machine on a slope.
- Never use a wire rope which has cut strands (A), reduced diameter (B), or kinks (C). There is danger that the rope may break during the towing operation.

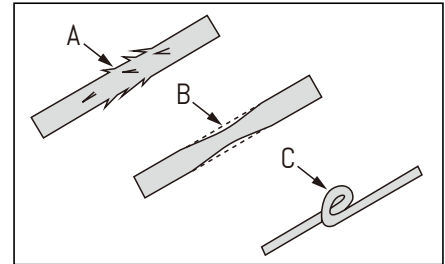
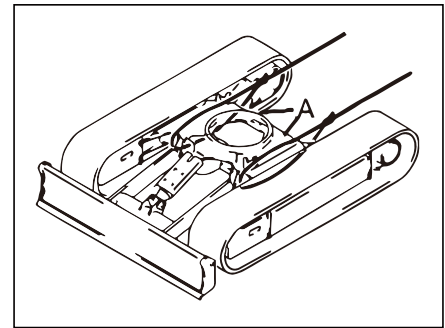

Lifting Work

Safety Rules for Lifting Objects

- Do not carry out lifting work on slopes, soft ground, or other places where the machine is not stable.
- Use wire rope that conforms to the specified standard.
- Do not exceed the specified lifting load.
- For details of the maximum lifting load permitted for this machine, see "Bucket with hook".
- It is dangerous if the load hits any worker or structure. Always check carefully that the surrounding area is safe before swinging or turning the machine.
- Do not start, swing, or stop the machine suddenly. There is a hazard that the lifted load will swing.
- Don't use two machines together to lift, it is very dangerous.
- Do not use the work equipment or swing to pull the load in any direction. There is danger that the hook may break and the load come off, causing the work equipment to move suddenly and cause personal injury.
- Do not leave the operator's seat when there is a raised load.
- Do not pull pile.

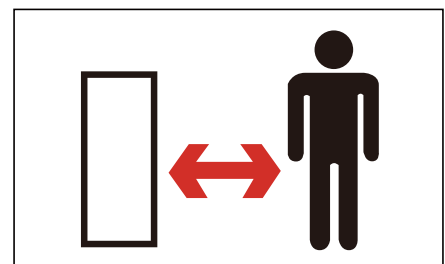

Safety Maintenance Information

Warning Tag

- Always attach the "DO NOT OPERATE" warning tag to the work equipment control lever. Attach additional warning tags around the machine if necessary.
- Keep this warning tag in the tool box while it is not used. If there is not the tool box, keep the tag in the operation manual pocket.
- If others start the engine, or touch or operate the work equipment control lever while you are performing service or maintenance, you could suffer serious injury or property damage.

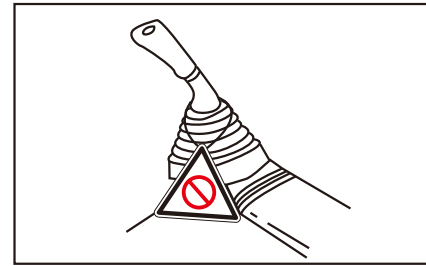

Keep Work Place Clean and Tidy

- Choose a flat and solid place.
- Choose a place where there is no danger of landslides, falling rocks or being flooded.
- Make the working device and the bulldozer fully contact the ground.

Appoint Leader When Working with Others

When repairing the machine or when removing and installing the work equipment, appoint a leader and follow his instructions during the operation.

When working with other people, if the meaning is conveyed incorrectly between the workers, it will cause accidents.

Turn off the Engine before Checking and Maintenance

- Park the machine on firm, level ground.
- Select a place where there is no hazard of falling rocks or landslides, or of flooding if the land is low.
- Lower the work equipment and Bulldozer completely to the ground.
- Check that the battery relay is off and main power is not conducted. (Wait for approx one minute after turning off the engine starting switch key and press the horn switch. If the horn does not sound, it is not activated.)
- Push up the work equipment control lever to middle position and push up lock lever to the LOCK position, then turn off the engine.
- Put blocks under the track to prevent the machine from moving.

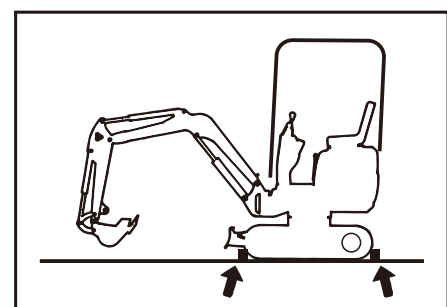
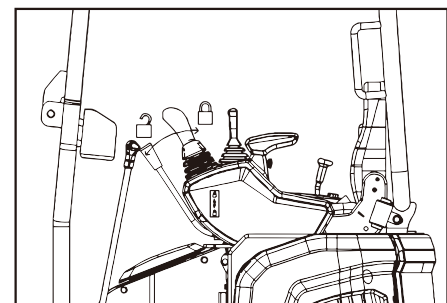

Two workers for maintenance when engine is running

To prevent injury, do not carry out maintenance with the engine running. If maintenance must be carried out with the engine running, carry out the operation with at least two workers and do as follows.

- One worker must always sit in the operator's seat and be ready to stop the engine at any time. All workers must maintain contact with the other workers.
- Set lock lever to the LOCK position (L).
- When carrying out operations near the fan, fan belt, or other rotating parts, there is a hazard of being caught in the parts, so be careful not to come close.
- Do not touch any control levers. If any control lever must be operated, give a signal to the other workers to warn them to move to a safe place.
- Never drop or insert tools or other objects into the fan or fan belt. Parts may break or be sent flying.

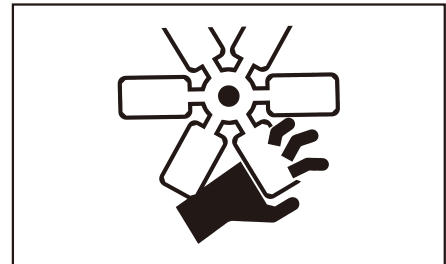
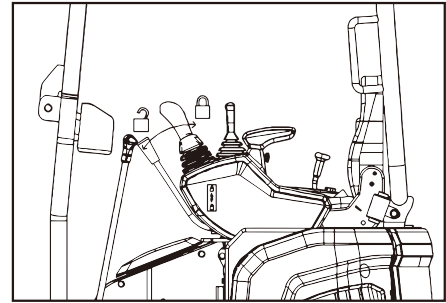

Proper tools

Use only tools suited to the task and be sure to use the tools correctly. Using damaged, low quality, faulty, makeshift tools or improper use of the tools could cause serious personal injury.



Personnel

Only authorized personnel can service and repair the machine. Do not allow unauthorized personnel into the area. If necessary, employ an observer.

Attachment

- Appoint a leader before starting removal or installation operations for attachments.
- Place attachments that have been removed from the machine in a stable condition so that they do not fall. And take steps to prevent unauthorized persons from entering the storage area.



Work under the machine

- If you must go under the work equipment or machine for service or maintenance, always support them securely with blocks and stands strong enough to bear their weight.
- Never rely on the work equipment alone for support. If the track shoes are off the ground and the machine is supported only by the work equipment, accidental movement of the control levers or hydraulic failure may cause it to drop suddenly.
- Never work under unsupported equipment or the machine—this is extremely dangerous and may result in serious injury or death.

Noise

When carrying out maintenance of the engine and you are exposed to noise for long periods of time, wear ear covers or ear plugs while working. If the noise from the machine is too loud, it may cause temporary or permanent hearing problems.

Hammer

When striking hard metal parts such as pins, bucket teeth, cutting edges, or bearings, metal fragments may scatter and cause serious injury.

- Always wear protective equipment such as goggles and gloves.
- Ensure no one is in the surrounding area before striking pins or bucket teeth to prevent injury from flying fragments.
- Do not strike pins with excessive force. Overstriking may cause the pin to fly out and injure people nearby.

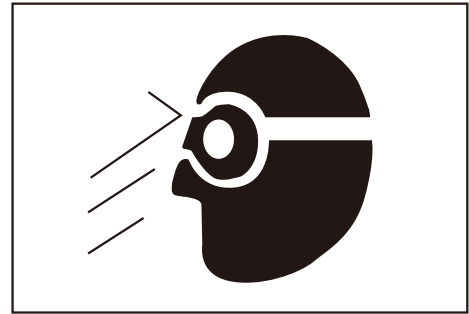

Welding works

Welding operations must always be carried out by a qualified welder and in a place equipped with proper equipment. There is a hazard of gas, fire, or electrocution when carrying out welding, so never allow any unqualified personnel to carry out welding.

Removing battery terminals

When repairing the electrical system or when carrying out electrical welding, remove the negative (-) terminal of the battery to prevent the flow of current.

Safety first when using high-pressure grease to adjust track tension

- Grease is pumped into the track tension adjustment system under high pressure. If the specified procedure for maintenance is not followed when making adjustment, grease drain plug (1) may fly out and cause serious injury or property damage.
- When loosening grease drain plug (1) to loosen the track tension, never loosen it more than one turn. Loosen the grease drain plug slowly.
- Do not place the face, hands, feet or other parts of the body close to the grease drain plug (1).

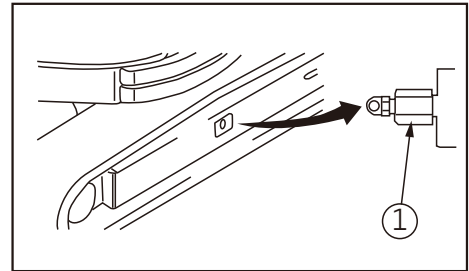

Do not disassemble recoil springs

Never attempt to disassemble the recoils spring assembly. It contains a spring under high pressure which serves as a shock absorber for the idler. If it is disassembled by mistake, the spring will fly out and cause serious injury. When it becomes necessary to disassemble it, ask your mechmaxx distributor to do the work.



High pressure oil

Hydraulic system is stressful. When inspecting or replacing the pipe or hose, be sure to check the pressure inside the hydraulic circuit has been released, otherwise, it will cause major accidents. So do as the following provisions:

- Release the pressure. When the hydraulic system has pressure, don't inspect and replace the operation.
- If there are any pipe or hose leaks, or its surrounding area is wet, check whether the pipe or hose burst, and whether the hose expansion. Wear protective equipment such as goggles and leather gloves, when check.
- High pressure oil from the hole leakage will penetrate into the skin, if it contact with eyes direction, you will be at the risk of blindness. If skin or eyes was hit by a high pressure oil, Rinse with clean water and contact the doctor immediately.



Operation of the pipeline and high pressure hose

If high pressure hose or pipeline leak, it will cause a fire or the operation failure, lead to major accidents. If you find the hose leaks or the installation of piping parts loose, stop working and tighten the installation site to specified torque again. If there is any damage on hose or piping or deformation, contact with the mechmaxx distributor.

The hose should be replaced, if existence as follows:

- Hose damage, pipe joint deformation, o-ring damage.
- Cladding torn or broken, or reinforcing steel wire exposed.
- Clad inflation in some places.
- Movable part of the hose distorted or signs of a crush.
- Cladding with foreign matter.

Waste materials

To prevent pollution, pay careful attention to the method of disposing of waste materials.

- Always put oil drained from your machine in containers. Never drain oil directly onto the ground or dump into the sewage system, rivers, the sea, or lakes.
- Obey appropriate laws and regulations when disposing of harmful objects such as oil, fuel, coolant, solvent, filters, and batteries.



Compressed air

- When carrying out cleaning with compressed air, there is a hazard of serious injury caused by flying particles.
- When using compressed air to clean elements or the radiator, always wear safety goggles, dust mask, gloves, and other protective equipment.

Periodic replacement of safety critical parts

- For using the machine safely for an extended period of time, replace safety-critical parts like hoses and seat belts periodically. Replacement of safety-critical parts: See "Safety Critical Parts".
- The material of these components naturally changes over time, and repeated use causes deterioration, wear, and fatigue. As a result, there is a hazard that these components may fail and cause serious injury or death. It is difficult to judge the remaining life of these components from external inspection or the feeling when operating, so always replace them at the specified interval.
- Replace or repair safety-critical parts if any defect is found, even when they have not reached the time specified interval.

OPERATION

WARNING



Before reading this chapter, please read and understand the security component.

General Drawing of Control Device

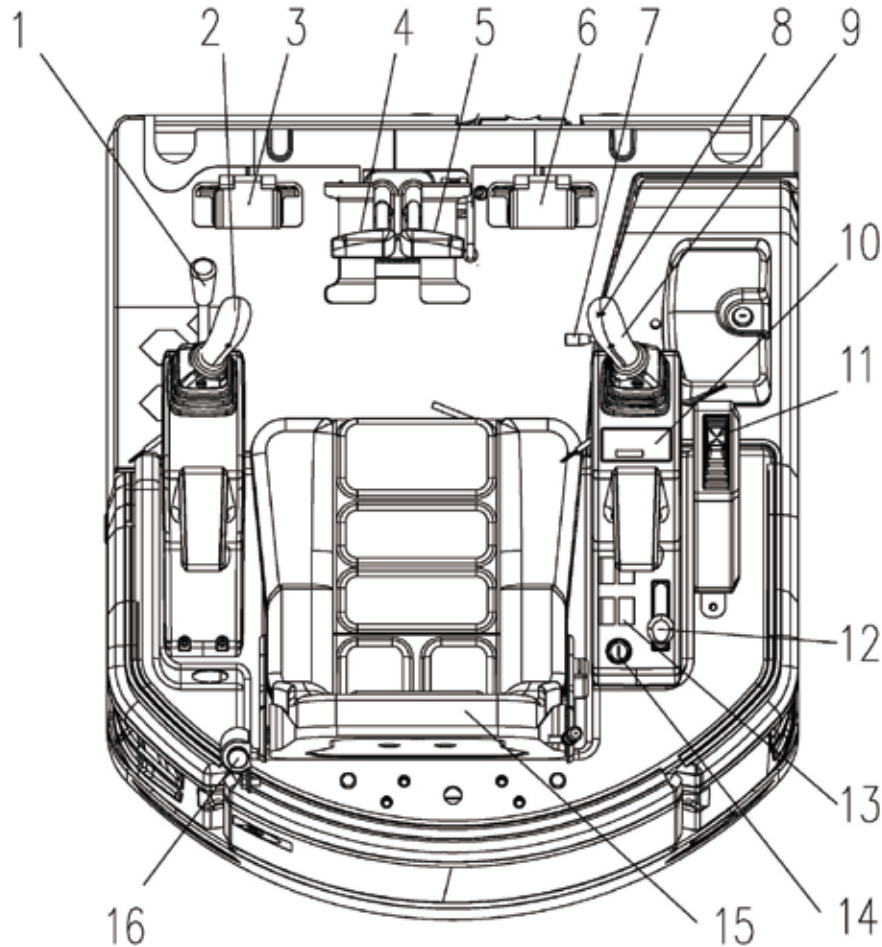

- | | |
|---|----------------------------------|
| 1. Security lock lever | 9. Right working device joystick |
| 2. Left working device joystick | 10. Monitor |
| 3. Auxiliary pipeline control | 11. Bulldozer control handle |
| 4. Left walking joystick | 12. Throttle joystick |
| 5. Right walking joystick | 13. Shift switch |
| 6. Boom side swing control | 14. Electric lock |
| 7. Bulldozing and under frame luffing switching operation | 15. Seat |
| 8. Speaker switch specified interval. | 16. Seat belt |

Description of Instrument and Control Device

The followings are the descriptions of how to operate the devices on the machine. In order to operate the devices correctly and safety, you shall understand the operation method and the meaning of the display.

Monitor



Home Screen

The main interface displays the working status, alarm signals, operation tips, etc. The display interface is a black background with different icons, and when special function alarm occurs, the icon will be highlighted.

Monitor Specification

- 1.Voltage: 24V DC (6~30V DC)
- 2.Operating Temperature: -30~+75 °C (-22~167 °F)
- 3.Storage Temperature: -40~+85 °C (-40~332.6 °F)
- 4.RH Humidity: 30%~90%
- 5.Atmospheric Pressure: 86~106 kpa
- 6.Protection level: IP65

Please strictly follow the above mentioned requirement to ensure the normally operation of the machine.

Power On:

When the instrument is powered on, it will show the following logo for 3 seconds, then enter into the user log-in interface or main interface:

User Log in Interface:

When the identity authentication is enabled, the instrument will automatically enter the user login interface (as shown in the figure below) for identity authentication. This function can be turned on or off in 'Main Menu-Operator Settings- Identity Authentication'. The login password can be modified in 'Main Menu- Operator Settings- Password Modification (default login password is 0000).

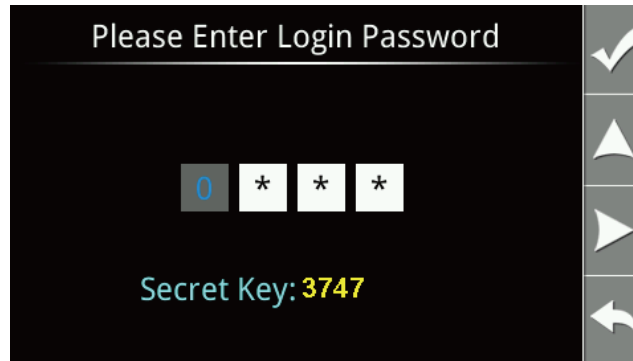

Main Interface:



System Voltage: Indicates the current system voltage value, range from 6~30V.

Beijing Time: Indicates the current date and Beijing time.

Pilot Switch Indication: Indicates the pilot switch status.

Water Temperature Pointer Dial: Indicates the current engine water temperature. When the temperature is higher than the alarm point, the icon on the main interface is always on, and the text will prompt 'The cooling water is too high, please check!' with buzzer sounds.

Warm Up Indication: Indicates the current preheating status.

Oil Level Pointer Dial: When the fuel level value is lower than the alarm point and lasts for 20 seconds, the icon on the main interface will be always on, and text prompts 'The fuel level is low, please check' with the buzzer sounds.

Engine Speed: Indicates the current engine speed, range from 0~3000rpm.

Tex Alarm: When the text alarm occurs, the specific text alarms will be displayed in this area, and if there are multiple text alarms, each text alarm will be displayed in turn.

Working Hour Meter: Indicates the current working hour. When the engine speed is ≥ 650 rpm or the charging signal line AMP34-21 is suspended or connected to a high level, the hour meter starts timing.

Menu Button: Pressure this button to enter the main menu interface.

Air Filter Alarm Indication: Reserved function to indicate when air filter is blocked.

High/Low Speed Button: Press this button to switch between 'High Speed Mode' and 'Low Speed Mode'.

Charging Indication: Indicates the current engine charging status.

Boom Light Button: Press this button to turn on or turn off the boom light.

Oil Pressure Indication: Indicates the current oil pressure.

Mute Button: When there is a buzzer, you can use this button to mute the sound. When the buzzer is in the mute status, you can cancel the mute by pressing this button.

Menu Interface :

Main Interface	Main Menu	Machine Information	Operating Parameters
			Machine Information
			Instrument Information
		Operator Setting (Password: 8888)	Identity Authentication
			Password Modification
		Preheating Setting	Preheating Function
			Preheating Time
		User Setting	Clock Setting
			Language Setting
			Brightness Setting
			Key Sound Setting
		System Setting (Password: 8888)	Alarm Parameter Setting
			Machine Information Setting
			Set Hour Meter Manually
		Instrument Setting (Password: 1234)	Factory Initialization (Not Currently Open to User)
			Recover Default Parameter (Password: 8888)

Main Menu Renderings :

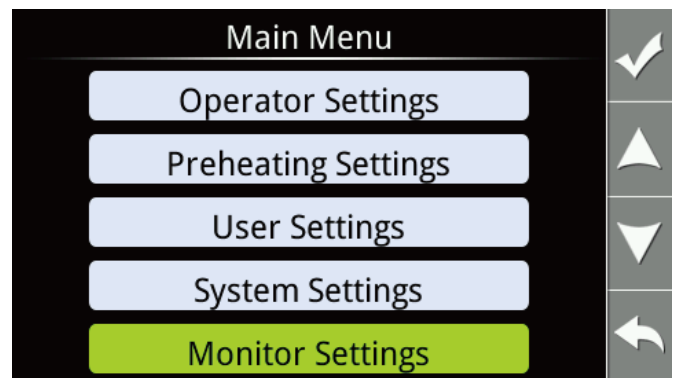
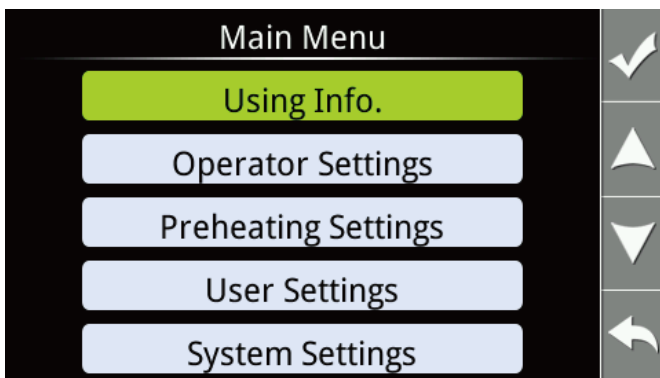

Running Parameters: Display the parameters or status of current system, viewing by pressing the button.

System Voltage	12.5V	Normal	✓	Pilot safe Sw	OFF	✓	
Engine Speed	0rpm	Normal		Power signal	ON		
Coolant Temp	≤ 40°C	Normal	▲	Start signal	OFF	▲	
Fuel Level	42%	Normal	▼	Start output	Disable	▼	
Charge alarm		Normal		Preheat output	Disable		
Engine Oil Pressure		Normal	←	BoomLight output	Disable	←	
1/3				2/3			
Travel output		Disable	✓				
Meter hour	0.7h		▲				
			▼				
			←				
3/3							

Machine Information: Indicates the machine serial number and the service number.

Machine Info.	
SN:	66SE01EJNN0000101
Tel:	400-000-1000
	←

Monitor Information: Indicates Monitor diagram number, Monitor serial number and the software version.

Monitor Info.	
Monitor Type:	YQ3.341.2420
SN:	RB1600001
Soft Version:	YQ0.280.1970V10.01
	←

Identity Authentication: You can set the authentication function on or off. When the function is enabled, it will enter the user login interface every time when the power is on. When the function is off.

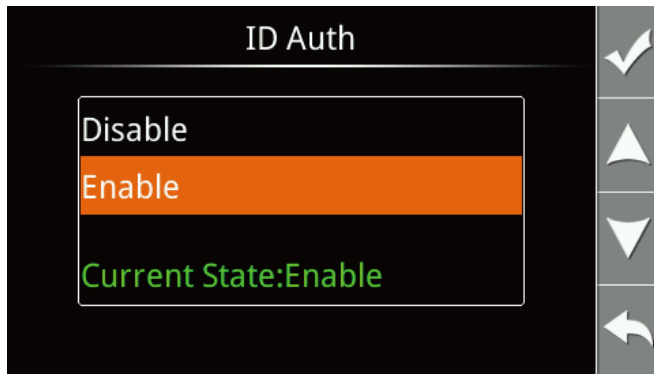

Login Password Set: Modify the user login password. (The default login password is 0000).

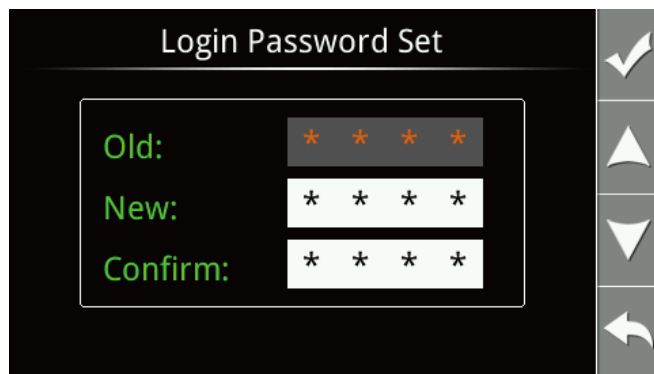

Preheat Function: You can set the preheat function to be on or off. When the preheat function is on, and the engine temperature is less than or equal to 40°C, the monitor will automatically preheat once when the power is on. When the preheat function is off, the automatic preheating will not be performed.

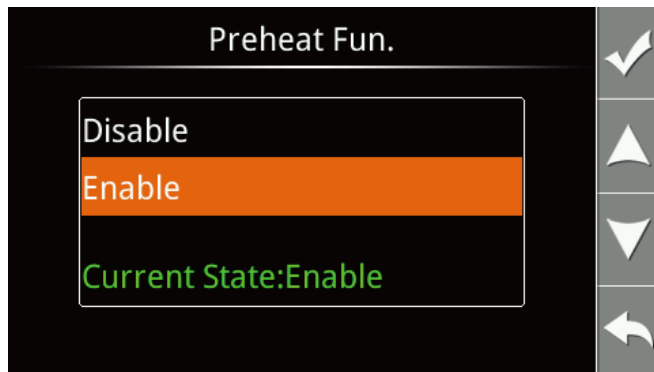

Preheat Time: You can set the automatically preheat time.

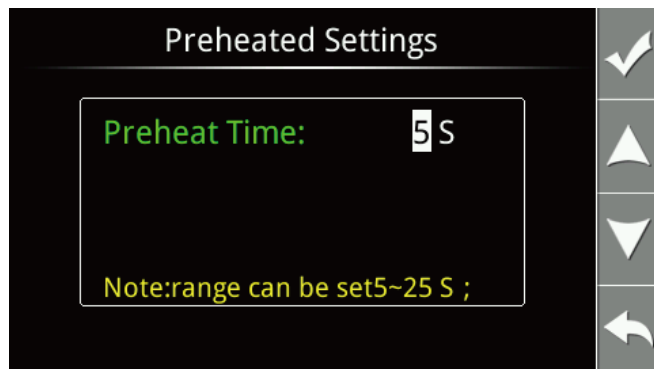

Adjust Clock: You can set the current date and the time.

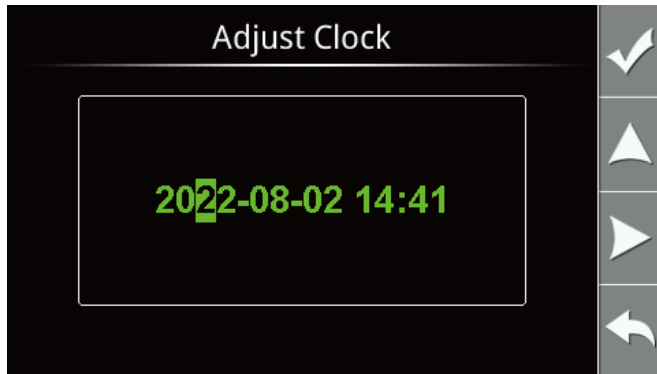

Brightness Setting: You can set the brightness of the screen.

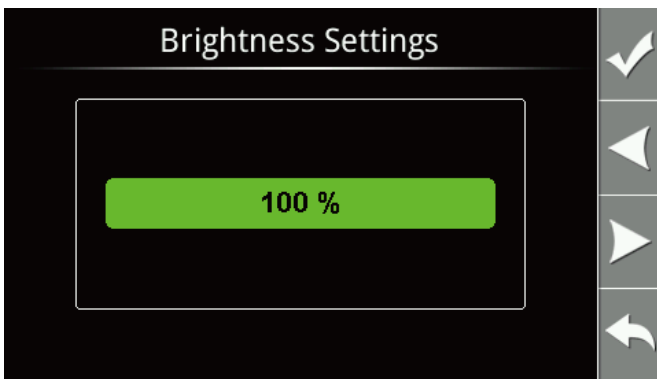

Key Sound Setting: You can set the key sound, the factory default is Enable.

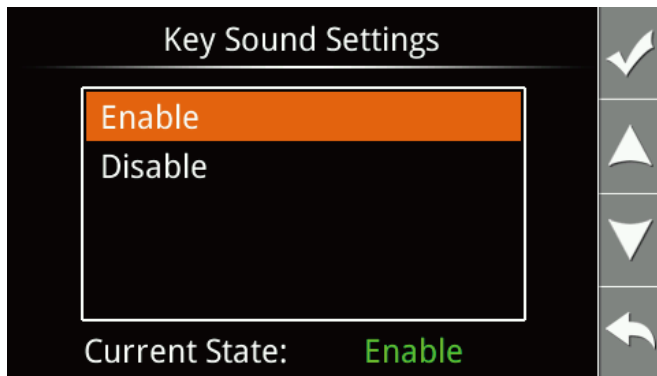

Alarm Date Setting: You can set the low oil level alarm point and the high water temperature alarm point. The factory default low oil level point is 10% and the high water temperature alarm point is 102 C.

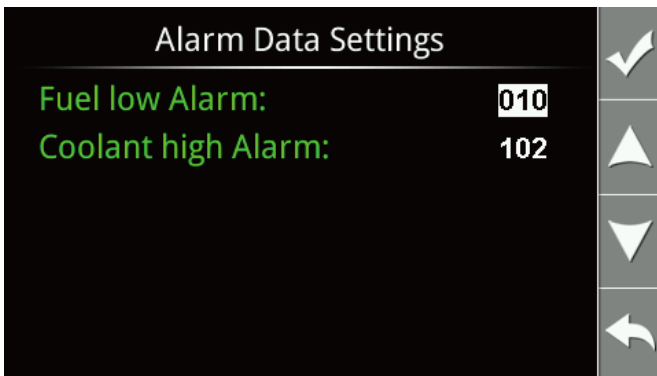

Machine Information Setting: You can set the serial number and service phone number

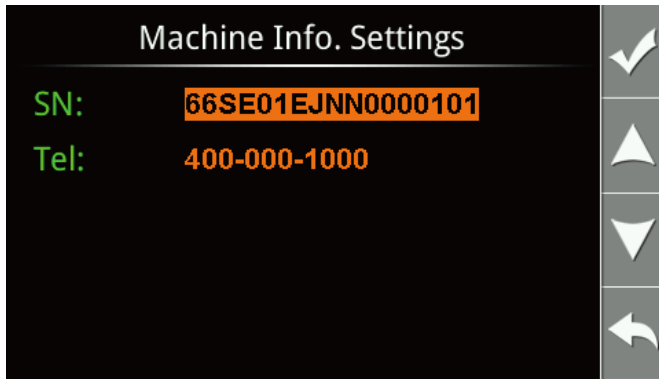

Factory Initialization: Not open to the user.

Reset Default Data: After performing 'Reset Default Data', the low oil level alarm point will be restored to 10%, and the high water temperature alarm point will be restored to 102 °C, and the user login password will be restored to 0000.ser.

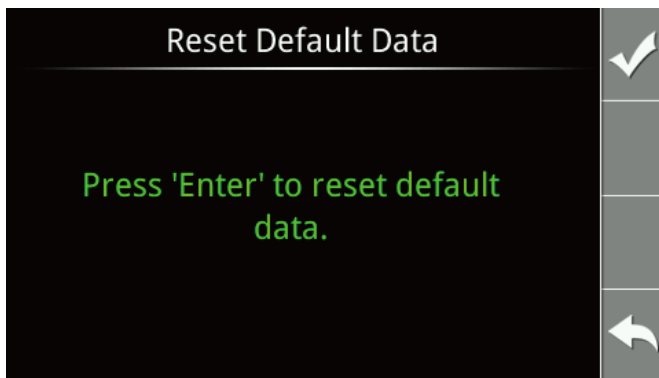

Alarm Fault Handling and Troubleshooting

While displaying the working status, the monitor can also monitor the working status of the engine's lubrication system, cooling system, intake system, and engine system.

1.High coolant temperature alarm: Indicates that coolant temperature is higher than the set value. In the event of a coolant temperature alarm, check in time whether the cooling system is short of coolant and whether there is coolant leakage, check whether the actual temperature of the water the coolant temperature sensor circuit is short.

2.Low oil pressure alarm: mainly from the following three aspects of troubleshooting

- Is the engine oil filter dirty?
- Is the engine oil pump working properly?
- Is there a lack of engine oil?

3.High hydraulic oil pressure alarm (only for models equipped with hydraulic oil pressure sensor): The pressure of the main pump of the hydraulic system is higher than the set pressure, and it is mainly checked from the following aspects:

- Check whether the main relief valve on the main valve is normal;
- Otherwise, please contact your nearest dealer for assistance.

WARNING



As soon as this alarm signal is displayed, it should be stopped immediately for inspection, otherwise the system will automatically reduce the engine speed to idle after the set time and record the failure time.

Low coolant level alarm: indicates that the liquid level of coolant in the cooling system is lower than the safe value, and should be checked at this time:

- Is the coolant in the auxiliary water tank below low?
- Whether the radiator is short of coolant, and whether there is a leakage in the radiator and the seals of each pipe.

Low fuel level alarm: indicates that the actual oil storage in the mailbox, at this time, check the fuel level in the fuel tank and fill up the fuel in time.

Air filter blockage alarm: indicates that the main filter element of the air filter is dirty, and the filter element of the air filter should be cleaned or replaced at this time.

Abnormal battery voltage: Low battery voltage: indicates that the battery voltage is below the set lower limit. At this point, try starting the engine once and determine the fault based on the actual situation:

- If the battery can start normally and the alarm disappears after ten minutes of machine operation, it belongs to a slight power loss and can be charged for a long time to solve the problem.
- If it can start normally and still alarm after ten minutes of machine operation, it is necessary to check whether the generator and charging circuit are normal and whether the battery is damaged.
- If the battery cannot start normally, it is considered to be severely depleted or damaged, and the battery should be repaired or replaced.

Battery voltage too high: indicates that the battery voltage is higher than the upper limit of the set value. At this time, the actual voltage of the battery should be measured (the working voltage should be 9V-16V when the engine is running normally). If the measured voltage is greater than 16V, the generator is faulty and should be repaired or replaced.

Other Control Devices

Speaker switch

When press the button on the top of the left control level, the speaker will sound.

Speaker function-check

1. Turn the key switch to the ON position.
2. Confirm that the speaker will sound when the speaker button on the right handle is pressed. If the speaker does not work, please contact mechmaxx dealer for repair.

Start switch

The switch is used to start or shut down the engine.

- OFF position

The key can be inserted or removed. All switches of the electrical system are closed and the engine is stopped.

- ON position

Current flows in the charging and lamp circuits. When the engine is running, keep the starter key in the ON position.

- START position

This is the engine start position. When starting the engine, keep the key in this position. After the engine starts, release the key immediately and it will automatically return to the ON position.

- HEAT (preheat) position

When starting the engine in winter, you must first turn the key to this position. The preheating time does not exceed 15s, and the preheating will be automatically disconnected if it exceeds 15s. After preheating, release the key immediately and it will automatically return to the OFF position.

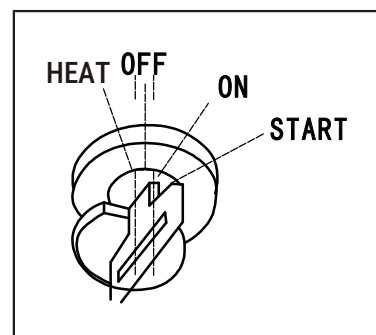
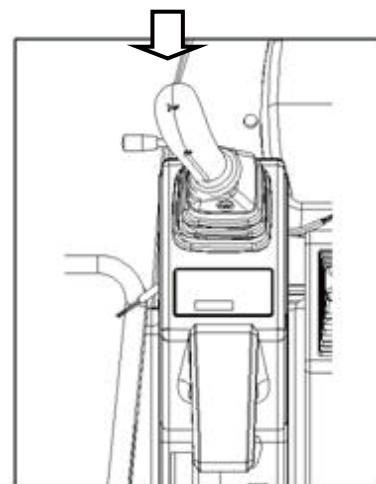



Work light switch

Control the switch of the boom work light

- Press ON  position: The light is ON.
- Press blank position: The light is OFF.

Two-speed switch

This switch is used to select low or high speed.

- Press to blank or  position: walking at low speed.
- Press to  position: walking at high speed.

Bulldoze (chassis telescopic) joystick

Notice

- When using a bulldozer to excavate continuously for more than 1 hour, pay attention to the rise in water temperature during this period. Used to control the lifting and falling of the bulldozer.
- Rear: The bulldozer is lifted, (after the function handle is switched) the chassis is retracted.
- Front: The bulldozer drops, (after the function handle is switched) the chassis extends.

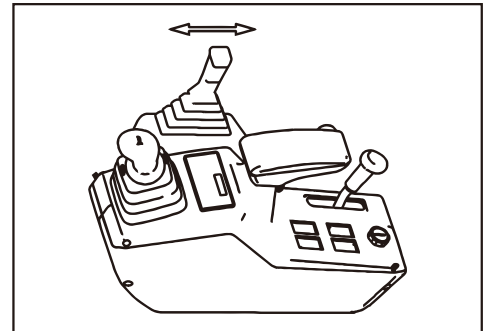

Lock lever

WARNING



- When leaving the operator's seat, set the lock lever securely to the LOCK position. If the lock lever is not at the lock position, and the control levers are touched by mistake, it may lead to serious personal injury.
- If the lock lever is not securely at the LOCK position, the lock lever may be moved, it may lead to serious accident or injury.
- When pulling the lock lever up, be careful not to touch the work equipment control lever.
- When pushing the lock lever down, be careful not to touch the work equipment control lever.

This lever is a device to lock the work equipment, swing, travel, and attachment (if equipped) control levers.

- LOCK position: The engine can be safely started or the operation can be stopped.
- FREE position: The excavator is allowed to operate normally.



Notice: This lock lever is of hydraulic lock type. Accordingly, when it is in the lock position, the control levers or control pedals move but the machine does not move.

Notice

- When the lock lever is at the LOCK position, allow to start the engine only, otherwise it can not work.
- The lock lever is at the FREE position, if the engine stops, set the lock lever to the LOCK position, then start the engine again.

Throttle knob

This knob is used to control engine speed and output power.

-  For the low speed position: push forward to reduce engine speed and power.
-  For the high speed position: Pull back to increase engine speed and power.

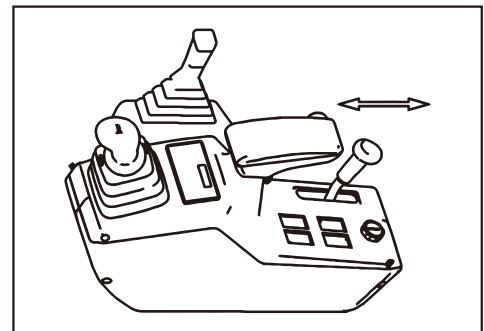

Working device control handle

WARNING



- Operation mode is set to standard mode(ISO mode)
- When you need to change the mode of operation, please contact the dealer.
- When changing the mode of operation, please replace operation signs to ensure consistent with the operation of the machine.
- The sticking position is locked on the right side of the seat.

Left work equipment control lever is used to turn and operate the arm.

- 1 Arm OUT
- 2 Arm IN
- 3 Swing to LEFT
- 4 Swing to RIGHT

Right work equipment control lever is used to operate the boom and bucket.

- 1 Boom LOWER
- 2 Boom RAISE
- 3 Bucket DUMP
- 4 Bucket CURL

Middle: The upper body and stick, boom and bucket remain in place.

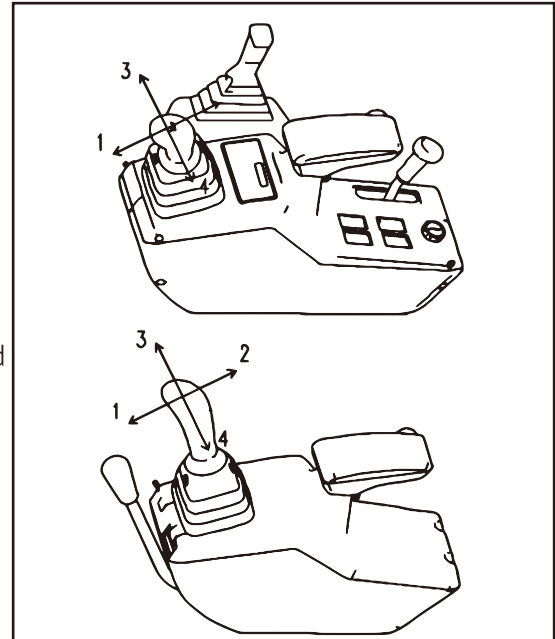
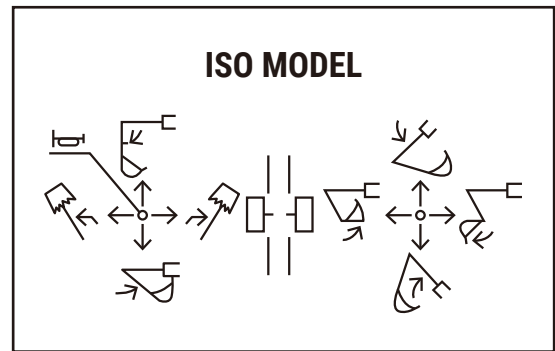

Travel levers

WARNING



- Do not rest your foot on the pedal during operations.
- When operating the walking handle/pedal (Optional), determine the walking direction of the crawler.
- The following description is for when the driving wheel is at the rear and the driving wheel is at the front, the walking operation sequence is reversed.

This lever is used to change the direction of travel between forward and reverse.

- Operating 1,3 simultaneously: retrogression.
- Operating 2,4 simultaneously: forward.
- Separate operation 4 or 1: turn right
- Separate operation 2 or 3: turn left
- Operating 1 or 4 simultaneously: turn right around
- Operating 2 or 3 simultaneously: turn left around

When the lever return to the middle position, the machine stops.

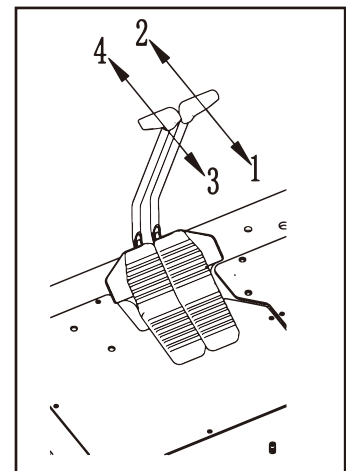

Equipment Lock

Both the fuel tank filler opening and the engine cover are equipped with locks. A key is required to open and lock these locks. For the location of the device lock, see the item "Locked".

Notice

Insert the key the end, then turn the key clockwise. If the key is turned before it is inserted all the way, it may break.

Fuel tank filling port and engine hood lock

There are three positions of the lock here. When the key is turned or released later, the key will automatically spring back to the middle position following the lock cylinder.

Ⓑ Opening the Lock

Insert the key into the key slot. Turn the key clockwise, then open the lock.

Ⓐ Locking the Lock

Insert the key into the key slot. Turn the key anticlockwise, then lock it.

Fuse

The machine is equipped with a central controller, which is installed under the seat. The internal fuse can prevent electrical equipment and wires from burning out. If the fuse box fuse is corroded or white powder can be seen, or the fuse is loose in the fuse holder, replace the fuse.

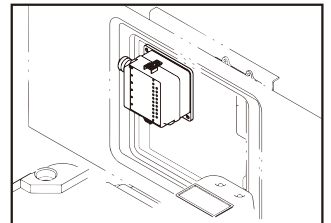
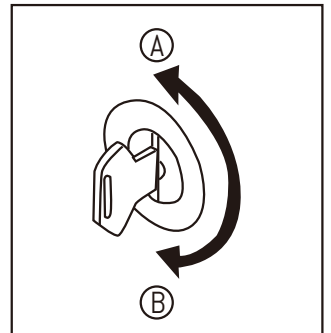
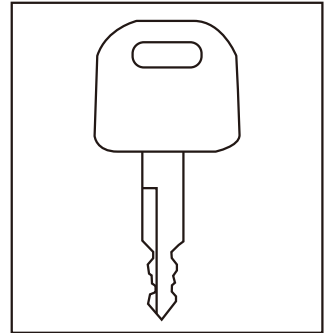

WARNING



- Before replacing a fuse, be sure to turn off the starting switch.
- Do not install the fuse that is specified on the label, otherwise there is a risk of damage to the circuit board or fire.
- Fuse burn off, must identify the cause of the fault, the party can be replaced.
- After the fuse is blown out, the fuse must be replaced with the same standard.
- When the fuse is corroded, the surface appears white powder or fuse is loose, should check and timely.
- The fused fuse can not be repaired, and should be replaced in a timely manner.

Fuse capacity and electrical name (from left to right, from top to bottom)

Number	MEC17	
	Fuse Capacity	Electrical name
1	20A	Start loop
2	20A	Charging loop
3	15A	Fuel pump
4	15A	Instrument
5	5A	Pilot circuit
6	10A	working lamp
7	5A	High and low speed
8	10A	trumpet
9	20A	spare
10	20A	spare

Battery Disconnect Switch

IMPORTANT

In addition to the following cases, this switch should be in the I (electrify) position,.

- Long term storage machine (more than one month)
- When repairing the electrical system
- When welding
- When handling the battery
- When replacing fuses and other parts

If you switch to the 0 (OFF) position, all electrical systems are switched off. This switch is used to cut off the current from the battery. Located in the machine right cover, you can see it when open the foot pad.

A: 0, (Off) position

B: I, (Electrify) position

Before operating the machine, always place the switch in position I.

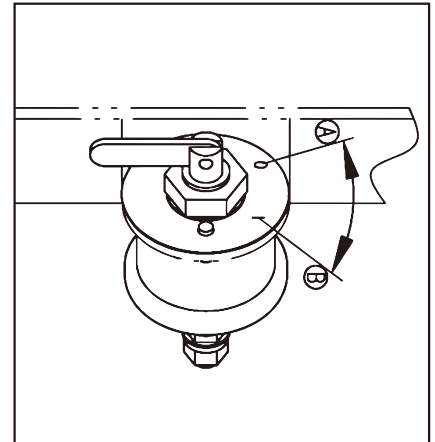

Machine Operations and Controls

Before Starting Engine

Walk-around checks

Before starting the engine, look around the machine and under the machine to check for loose nuts or bolts, or leakage of oil, fuel, or coolant, and check the condition of the work equipment and hydraulic system.

Check also for loose wiring, play, and accumulation of dust at places, which reach high temperatures.

WARNING



- Before inspection and maintenance, the rear engine cover, side door and right front cover must be opened and fixed.
- Clean the flammable materials around the battery, engine muffler or other high-temperature engine parts. Fuel or oil leakage can cause the machine to catch fire. Check carefully and repair any abnormalities or contact the dealer.

During the inspection, if the machine is tilted, make it level before proceeding with the inspection. Before starting the engine every day, check the following items in this section.

1. Check whether the working device, cylinder, connecting rod, hose are damaged, worn or have gaps

Check the working device, cylinder, connecting rod or hose for cracks, excessive wear or gaps. If any problem is found, repair it.

2. Remove dirt and debris from around the engine, battery, and radiator.

Check for dirt accumulated around the engine and radiator. Also check for flammable material (dry leaves, twigs, etc.) around the battery, engine muffler, turbocharger, or other high temperature engine parts. If any dirt or flammable materials are found, remove them.

3. Check for coolant and oil leakage around the engine.

Check for oil leakage from the engine and coolant leaks from the cooling system. If any problem is found, repair it.

4. Check for oil leakage from hydraulic equipment, hydraulic tank, hoses, and joints

Check for oil leakage.

If any problem is found, repair the area where oil is leaking.

5. Check whether the grease pipeline leaks grease.

If any problem is found, repair it.

6. Check whether the monitor is damaged and whether the bolts are loose.

The monitor should be undamaged. If an abnormality is found, replace the parts. Remove foreign objects on the surface.

7. Seat belt and mounting clamps

Check for damage or wear to the seat belt and mounting clamps. If there is any damage, replace with new parts.

8. Check bucket with hook (if equipped) for damage.

Check for damage to the hook, guide, and hook mount. If any problem is found, contact your mechmaxx distributor for repairs.

Checks before Starting

Always check the items in this section before starting the engine each day.

Coolant Level: Check or Add

WARNING



- Do not open the radiator cap unless necessary. Wait for the engine to cool down before checking the coolant in the sub-tank.
- Immediately after the engine is stopped, the coolant is at a high temperature and the radiator is under high internal pressure.
- If the cap is removed to check the coolant level in this condition, there is a hazard of burns. Wait for the temperature to go down, then turn the cap slowly to release the pressure before removing it.

Check and add the machine at the level of the place.

Check the coolant level before starting every day.

1. Open the rear hood (1), and ensure that the support rod (2) falls into the slot to lock, so as to avoid the side door collision.

2. Check the coolant level of sub-tank (3).

- If the coolant level is between the FULL and LOW marks means normal.
- If the coolant level is low, add coolant to the FULL level through the filler port of sub-tank (3).
- If the sub-tank (3) is empty, there is probably leakage of coolant. After inspecting, repair any problem immediately.

3. At the same time of press the radiator cap (4), unscrew the cove until it comes into contact with the brake and remove the cover. Check the coolant level of the radiator, if lacking of coolant, then add coolant and check whether there is any leakage on line.

4. Check the rubber hoses and pipe clamps for damage, cracks and looseness, and tighten them immediately if they are loose. If damaged, the hose or pipe clamp must be replaced immediately, otherwise the engine is not allowed to start.

Pipe clamp tightening torque of $5.9 \pm 0.49 \text{ N} \cdot \text{m}$ ($60 \pm 5 \text{ kg} \cdot \text{cm}$)

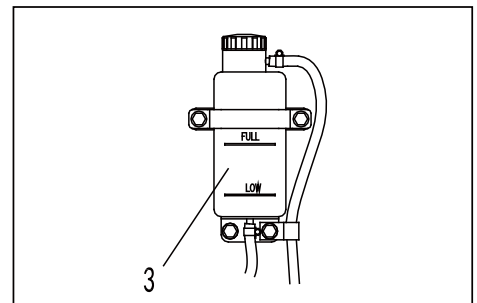
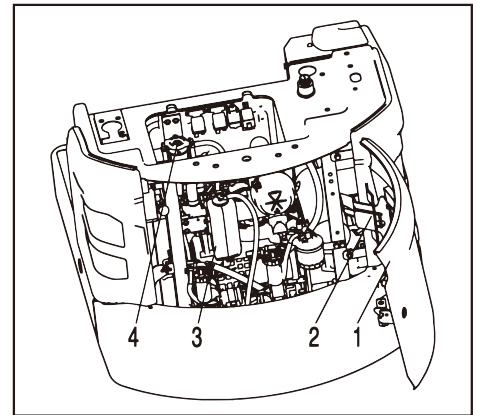

Oil Level in Engine: Check or Add

WARNING



Parts and oil are at high temperature immediately after the engine is stopped and may cause serious burns. Wait for the oil temperature to go down before performing this operation.

When performing inspection and maintenance inside the hood, the hood must be fully opened and locked with struts.

1. Open the hood and lock it with a strut.

2. Remove dipstick (3), and wipe the oil off with a clean cloth.

3. Fully insert dipstick (3) into filler pipe, then remove it.

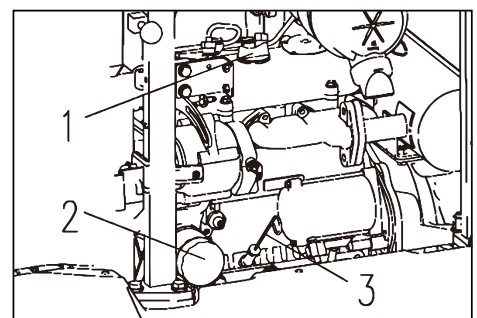

4. The oil level should be between the H and L marks on dipstick (3). If the oil level is below the L mark, add engine oil through oil filler (1).

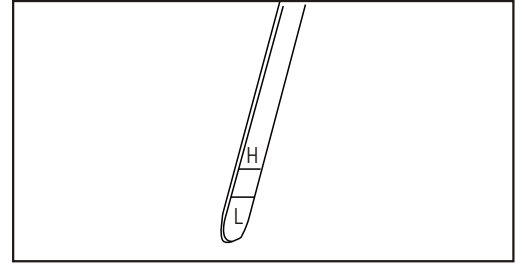

5. If the oil is above the H line, open drain valve (P) at the bottom of the engine oil pan, drain the excess engine oil, then check the oil level again.

6. If oil level is correct, securely tighten the oil filler cap and close the engine hood.

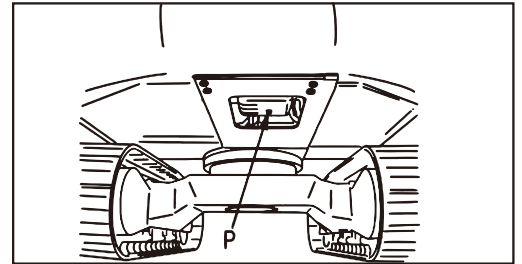

NOTICE

- When checking the oil level after the engine has been operated, wait for at least 15 minutes after stopping the engine before checking.
- If the machine is inclined, make it to a horizontal position before checking.
- The position of dipstick and discharge plug may be different for different models.

Fuel Level: Check or Add

WARNING



When adding fuel, never let the fuel overflow. This may cause a fire. If any fuel is spilled, wipe it up completely. Never bring flames near fuel because it is highly flammable and dangerous.

1. According to the fuel oil level on the monitor to check the amount of oil in tank.

2. If the fuel level is within the red scale of the oil level, add fuel through the injection port (F).

Fuel tank capacity: 19 liters

3. Tighten the cover and locked after refueling.

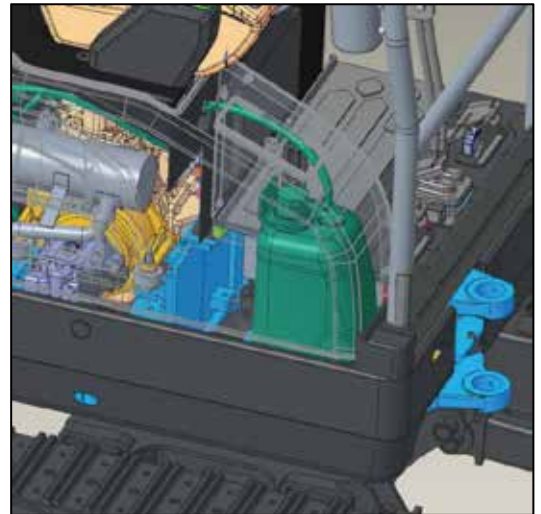

REMARK

- If breather hole ① in the cap is clogged, the pressure in the tank will drop and fuel will not flow.
- Clean the hole from time to time.

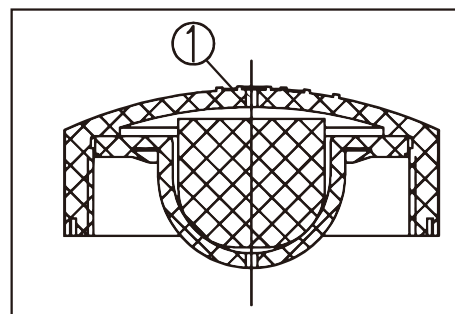

Oil Level of Hydraulic :Check or Add

WARNING



After stopping the engine, the parts and hydraulic oil are still at high temperature, which may cause burns. Therefore, wait until the temperature drops before starting work.

If the working device is not in the state shown in the figure on the right, start the engine and run the engine at a low idle speed. Fully retract the arm and bucket cylinder rod, then lower the boom, adjust the bucket teeth to the ground contact position, and turn off the engine.

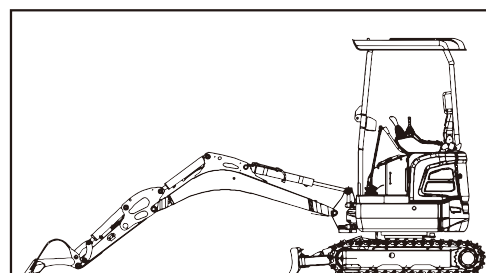

Within 15 seconds after turning off the engine, turn the safety lock switch to the ON position, and operate the joystick (working device, walking) in each direction to release the internal pressure.

Check the level gauge on the hydraulic oil tank. The oil level must be between the marks on the level gauge, otherwise hydraulic oil needs to be filled.

The refueling steps are as follows:

1. Use the key to open the fuel cap lock;
2. Unscrew the fuel filler bolt;
3. Add hydraulic oil and check the level gauge again;
4. Tighten the fuel filler bolt and lock the fuel filler lock.

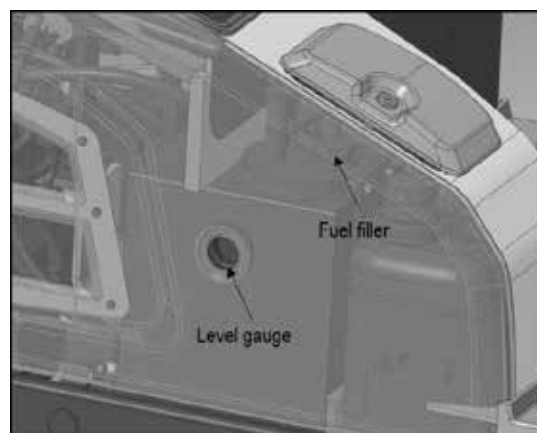

Air Cleaner Dust Indicator (optional): Check

IMPORTANCE

- Only when the pressure difference indicator (1) pops out and the red mark is visible. The air filter needs to be cleaned, otherwise there is no need to clean the air filter element.
- If the air filter element is cleaned frequently before the pressure difference indicator has not warned, The performance of the air filter will not be fully exerted, and its filtering effect will be deteriorated.
- In addition, the dirt attached to the filter element during cleaning will frequently fall to the inner filter element side and be sucked into the engine, causing engine wear.

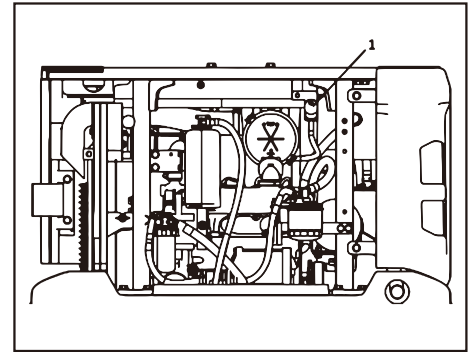

When the pressure difference indicator (1) pops up and shows red, clean or replace the filter element immediately. For details about cleaning the filter element, see "Air Filter-Inspection/Cleaning/Replacement" in Inspection and Maintenance.

Fuel pre-filter: check or drain or clean

The fuel pre-filter is inspected and drained, and cleaned if necessary:

1. Open the rear hood of the engine and lock it with a strut.
2. Observe the water cup. If there are impurities inside the water cup, close the valve, place a cloth outside the water cup, use the filter element wrench to turn left to remove the water cup, and clean the water cup with clean diesel.
3. After the water cup is cleaned, use the filter element wrench to turn clockwise to install the water cup back.
4. Open the valve, loosen the strut, and close the rear hood of the engine.

IMPORTANCE

- The collector cup need to emissions, should not until the pre-filter separator alarm after discharge set the water in the glass, once the fuel oil mixed with water, will cause harm to the engine.
- When the water cup has impurities, need to clean the collector cup immediately, or else impurities into the engine block, or engine early wear.
- The location of the fuel prefilter may be different for different models.

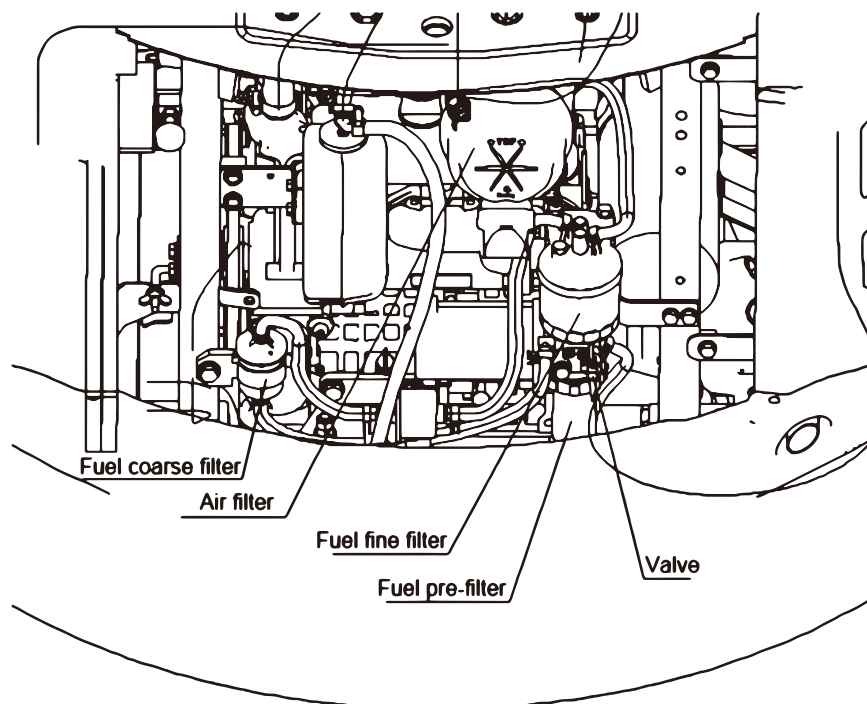

Electric Wiring: Check

WARNING



- If the fuses frequently blow or if there are traces of short circuits in the electrical wiring, locate the cause and immediately perform repairs, or contact your mechmaxx distributor for repairs.
- Be sure to check that there is no inflammable material accumulated around the battery. If present, remove it as soon as possible.
- Keep the top surface of the battery clean and check the breather hole in the battery cap. If it is clogged with dirt or dust, wash the battery cap to clean the breather hole.

Check whether the fuse is damaged and the capacity of the fuse used is appropriate. Check the circuit for signs of open circuit or short circuit, and check whether the terminals are loose. Tighten the loose terminal.

Pay particular attention to the electric wiring when checking the battery, engine starting motor and alternator.

Also check that there is no inflammable material accumulated around the engine. If present, remove it as soon as possible.

For inquiries about the causes and corrective suggestions, please contact your mechmaxx distributors.

Adjustment

WARNING



- Adjust the operator's seat, control box and rear view mirror before starting each operation or when the operators change shift.
- Adjust the operator's seat so control levers and switches can be operated freely and easily with the operator's back against the backrest.

Seat Adjustment

IMPORTANCE

In order to obtain the best possible comfort, it is important to adjust the seat in the correct way.

Statement: Assemble different types of seats and seat adjustment methods are different, please operate according to the actual situation.

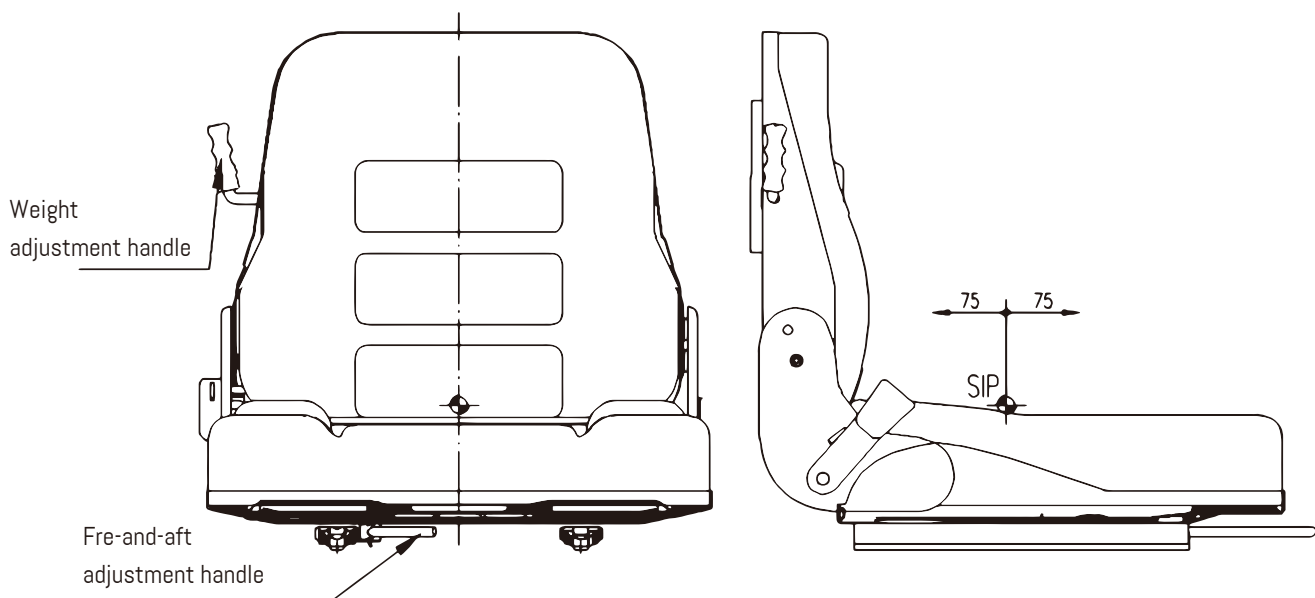

Weight adjustment

According to the operator's own weight, rotate the weight adjustment handle, adjust to the appropriate position. There are three levels of adjustment gears.

Fore-and-aft adjustment

Lift up the seat lever to adjust the entire seat forward or backward. The maximum seat adjustment is 75mm. (This adjustment is the adjustment of the seat rod itself, does not include the adjustment of the slide plate)

Backrest angle adjustment

The seat back can be adjusted forward or backward by a total of 15°.

Seat belt

WARNING



- Before fitting the seat belt, check that there is no problem in the belt mount bracket or mounting belt. If it is worn or damaged, replace the seat belt.
- Even if no problem can be seen in the belt, replace the seat belt every 2 years.
- To adjust seat before operation.
- Always wear the seat belt during operations.
- Fit the seat belt so that it is not twisted.

If the seat belt is worn or damaged or accidentally deformed, replace the seat belt.

If the seat belt needs cleaning, it must be:

- Use neutral soap liquid.
- Before the belt is rolled up, allow it to dry in the sufficiently stretched condition.

Fasten and unfasten the seat belt

1. Sitting in a seat on the seat, allow the operator back against the seat back of a chair, in order to work.
2. Hold grip and pull the belt out from wind-in device, check that the belt is not twisted, then insert tongue into buckle securely.
3. Remove the seat belt, should carry handle with front end, to remove your seat belt.

REMARK

Adjust the fixed card buckle the length of the side, make against the body and avoid kink belt.

Operations before Starting Engine

WARNING



- When starting the engine, check that the lock lever is securely at the LOCK position.
- If the lock lever is not locked securely and the control levers or control pedal are touched when the engine is started, the machine may move unexpectedly, and this may lead to serious personal injury.
- When standing up from the seat, be sure to set the lock lever at the LOCK position, regardless of whether the engine is running.

1. Confirm the battery cut-off switch in position I (electrify).

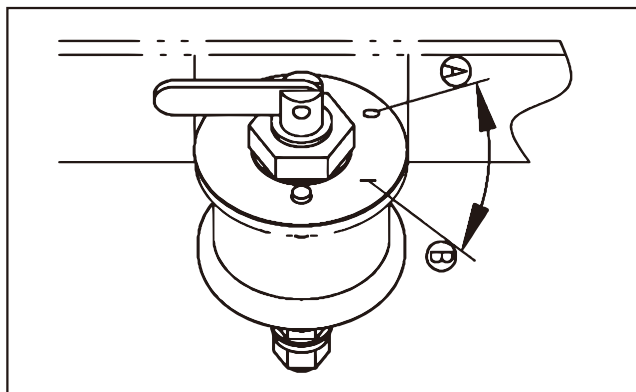

2. Check if the lock lever is at the LOCK position.

If lock lever is not at the LOCK position, do not starting engine..

3. Check the position of each lever.

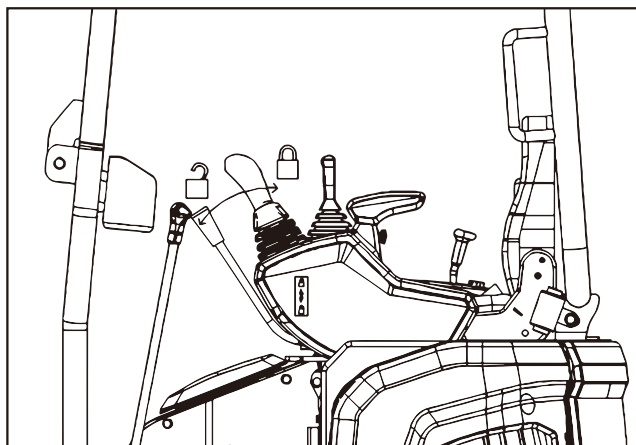

Starting Engine

Normal Starting

WARNING



- Start the engine only after sitting down in the operator's seat.
- Do not attempt to start the engine by short-circuiting the engine starting circuit. Such an act may cause a serious bodily injury or fire.
- Check that there are no persons or obstacles in the surrounding area, then sound the speaker and start the engine.
- Exhaust gas is toxic. When starting the engine in confined spaces, be particularly careful to ensure good ventilation.

IMPORTANCE

Do not crank the starting motor continuously for more than 20 seconds. If the engine does not start, wait for at least 2 minutes before trying again.

1. To ensure the safety lock handle in the locked position, if the safety lock lever is not in the locked position, don't start the engine.

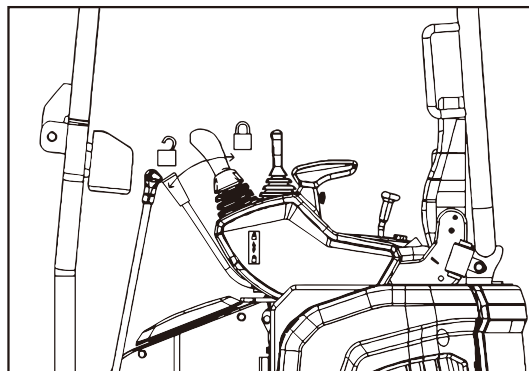

2. Turn the key in starting switch to the START position. The engine will start.

3. After the engine starts, release the key in starting switch. The key will automatically return to the ON position.

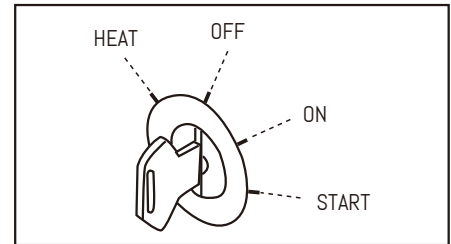

Starting Engine in Cold Weather

WARNING



- Start the engine only after sitting down in the operator's seat.
- Do not attempt to start the engine by short-circuiting the engine starting circuit. Such an act may cause a serious bodily injury or fire.
- Check that there are no persons or obstacles in the surrounding area, then sound the horn and start the engine.
- Never use starter aids to start the engine, as they can cause an explosion.
- Exhaust gas is toxic. When starting the engine in confined spaces, be particularly careful to ensure good ventilation.

IMPORTANCE

Do not crank the starting motor continuously for more than 20 seconds. If the engine does not start, wait for at least 2 minutes before trying again.

When starting in low temperatures, do as follows (Machine with warm-up function performs this operation).

1. To ensure the safety lock handle in the locked position if the safety lock lever is not in the locked position, don't start the engine.

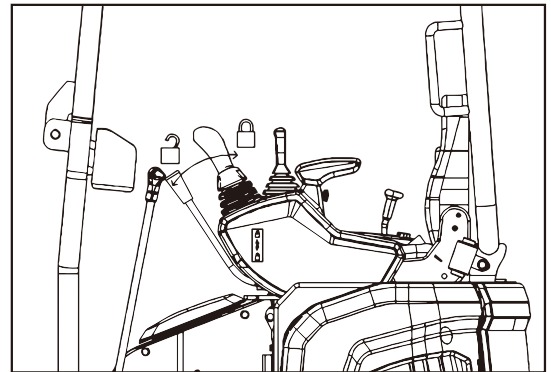

2. Keep the start switch key at the HEAT (preheat) position, the preheating time does not exceed 15s, and it will automatically cut off preheating if it exceeds 15s. After preheating, release the key immediately and it will automatically return to the OFF position.

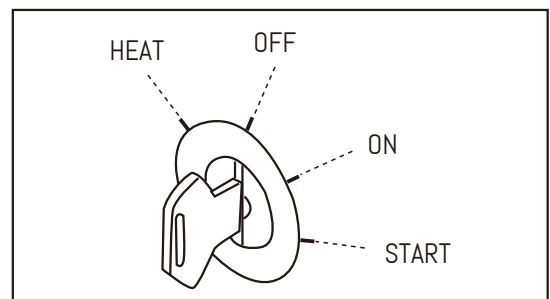

3. Turn the key in starting switch to the START position to start the engine.

4. After the engine starts, release the key in starting switch. The key will automatically return to the ON position.

After Starting Engine

WARNING



- Emergency stop If any trouble occurs, turn the starting switch to the OFF position.
- If the work equipment is operated without carrying out the warming-up operation properly, the reaction of the work equipment to the operation of the control lever will be slow and the work equipment may not move as the operator intends. To prevent such problems, always be sure to carry out the warming-up operation fully. In cold weather particularly, be extremely careful to carry out the warming-up operation fully.

Breaking in the New Machine

WARNING



The machine has been thoroughly adjusted and tested before shipment from the factory. However, operating the machine under full load before breaking the machine in can adversely affect the performance and shorten the machine life.

Be sure to break in the machine for the initial 100 hours (as indicated on the service meter).

During the running-in operation, observe the precautions required in this manual.

- Run the engine at idle for 5 minutes after starting it.
- Avoid operation with heavy loads or at high speeds.
- Avoid sudden starts, sudden acceleration, unnecessary sudden stops, and sudden changes in direction.

Warming up operation

IMPORTANCE

- No operation or sudden operation of the joystick is allowed under the condition of low temperature of hydraulic oil. Warm-up operation must be carried out first to prolong the service life of the machine.
- After starting the engine, don't make the engine accelerate suddenly until the warm-up operation is completed. Especially in cold weather, if the engine accelerates suddenly, it will emit white smoke, but this does not mean abnormal.
- Do not run the engine continuously at low or high idle speeds for more than 20 minutes.
- If it is necessary to run the engine continuously at idle speed, the engine should be loaded from time to time or run at medium speed.

Do not start operation immediately after starting the engine. First, perform the following operations and checks.

1. Turn fuel control dial to center position between the low idle and high idle positions and run the engine at a mid-range speed about 5 minutes.

REMARK

When the temperature is lower than 32°F, turn the throttle knob to the middle and low speed position for warm-up operation.

2. Place the safety lock lever in the unlock position and raise the bucket from the ground.
3. Slowly operate the left and right joysticks to move the bucket cylinder and stick cylinder to the end of the stroke

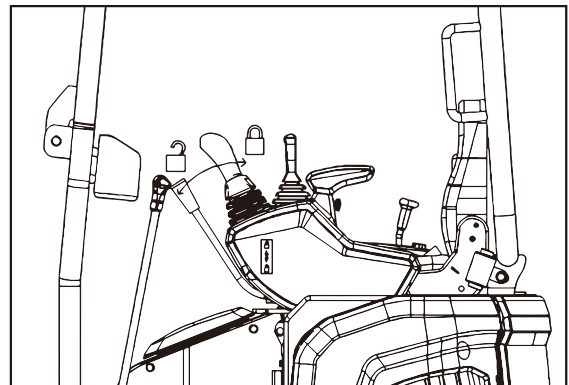

IMPORTANCE

When the work equipment is retracted, take care that it does not interfere with the machine body or ground.

4. Operate the bucket and the arm in turn fully for 5 minutes. (Left handle 1,2 and right handle 3,4).

5. After performing the warming-up operation, check and be sure all the gauges on machine monitor and the caution lamps are in the following conditions:

- Fuel level monitor in the green range;
- Coolant temperature monitor in the green range;
- No alarm icon is displayed in the central area of the interface.

6. Check for abnormal exhaust gas color, noise, or vibration. If any problem is found, contact your mechmaxx distributor.

7. Set lock lever slowly and securely to LOCK position, and make sure that the left and right control levels are not operated for turning and operating devices.

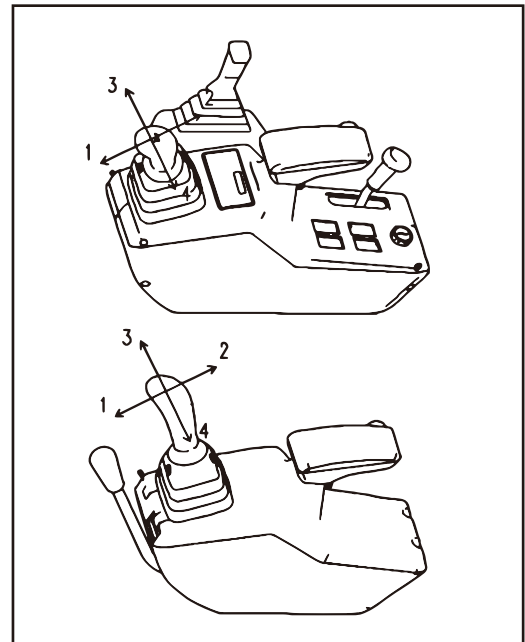

Stopping the Engine

IMPORTANCE

If the engine is stopped abruptly, service life of component parts of the engine may be considerably reduced. Do not stop the engine abruptly except in an emergency.

If the engine has overheated, do not try to stop it abruptly but run it at medium speed to allow it to cool down gradually, and then stop it.

1. Run the engine at low idle speed for about 5 minutes to cool down gradually.
2. Turn the key in starting switch to the OFF position and stop the engine.
3. Remove the key from starting switch.

Check after Shut off Engine

1. Walk around the machine and check the work equipment, machine exterior, and undercarriage, also check for any leakage of oil or coolant. If any problems are found, repair them.
2. Fill the fuel tank.
3. Check the engine compartment for paper and debris. Clean out any paper and debris to avoid a fire hazard.
4. Remove any mud affixed to the undercarriage.

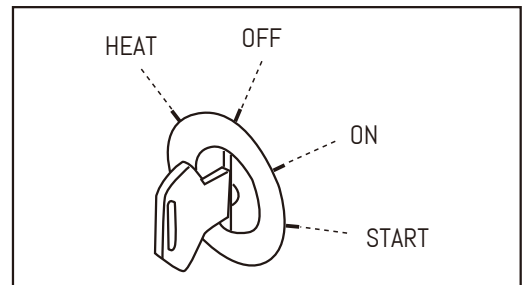

Machine Operation: Move and Stop

Matters Need Attention of Moving the Machine

WARNING



- Before operating the control lever, check the direction of the track frame. If the sprocket is at the front, the machine moves in the opposite direction from the operation of the travel lever.
- Before starting the machine, check that the area around the machine is safe and sound the speaker.
- Do not allow anyone to enter the area around the machine.
- Clear any obstacles from the travel path.
- Here is a blind spot at the rear of the machine, so be particularly careful when traveling in reverse.

Preparation before the machine moves

Pull the throttle lever back to increase the engine speed.

Moving Forward

1. Open the safety lock lever, put away the working device and lift it 1.57-1.97 in from the ground.
2. Pull the blade control lever backward to raise the blade.
3. Operate the walking joystick according to the following steps.

- When the driving wheel (A) is at the back of the machine, slowly push the left and right walking joysticks forward to move the machine.

- When the driving wheel (A) is at the front of the machine, slowly pull the left and right walking joysticks back to move the machine

4. Follow the steps below to switch the walking speed.

Press the walking speed switch to the high-end "rabbit gear" to switch from low-speed walking to high-speed walking.

Press the walking speed switch to low gear to switch from high speed to low speed.

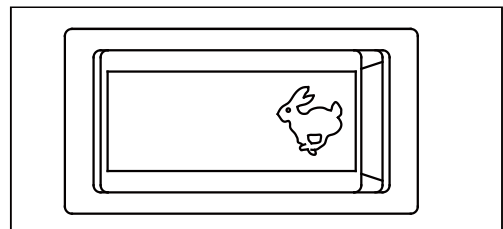
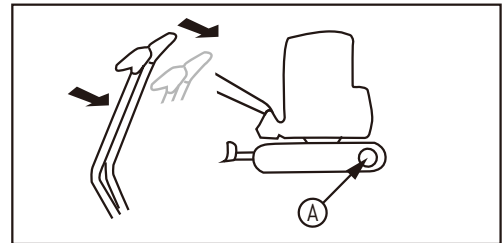
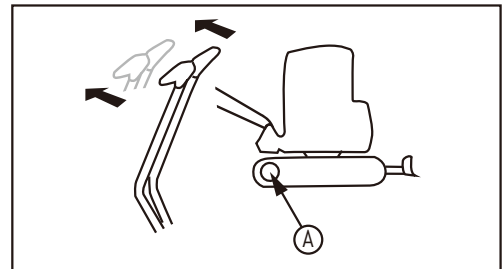
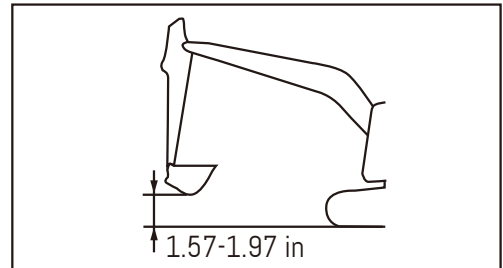
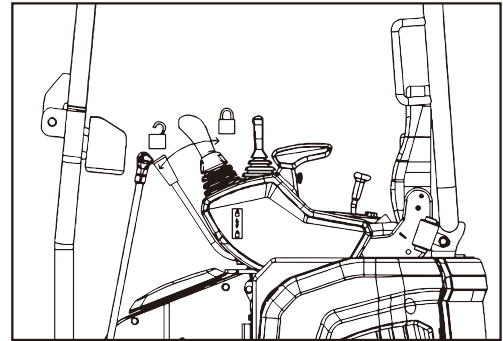

Moving Machine Backward

1. Raise the safety lock lever, put away the working device and lift it 40-50cm from the ground.
2. Pull the dozer lever backward to raise the dozer.

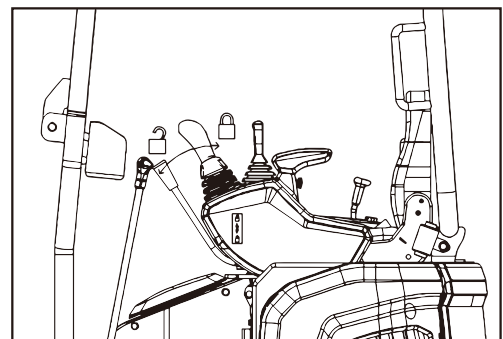

3. Operate the travel levers as follows:

- When sprocket (A) is at the rear of the machine:
Slowly pull the joystick back to move the machine.
- When sprocket (A) is at the front of the machine:
Slowly push the joystick forward to move the machine.

4. The walking speed switching mode is consistent with the "speed forward" method.

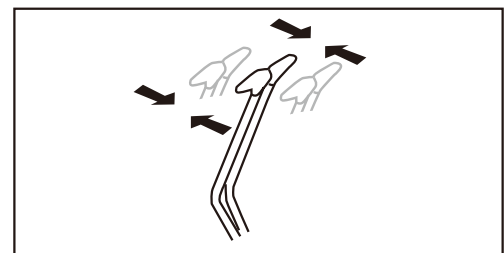
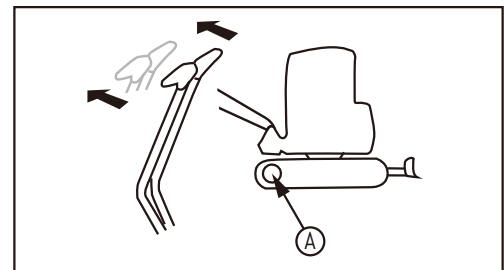
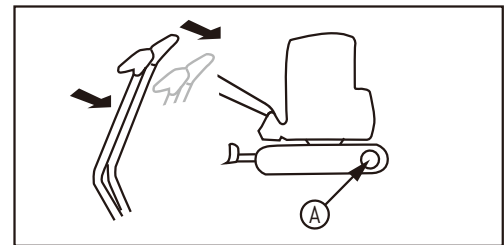
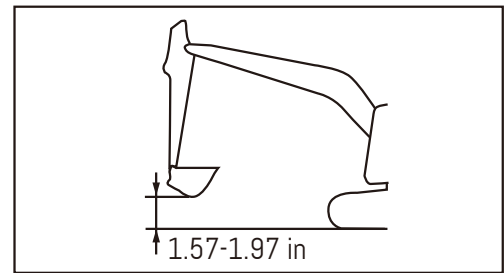

Stopping Machine

Avoid stopping suddenly. Give yourself ample room when stopping. Put the left and right travel levers in the neutral position, then stop the machine.

Steering the Machine

Steering

WARNING



Before operating the travel levers, check the direction of the track frame. If the sprocket is at the rear, the machine moves in the reverse direction to the operation of the travel levers.

Use the travel levers to change direction.

Avoid sudden changes of direction as much as possible. Especially when performing counter-rotation (spin turn), stop the machine before turning.

Operate two travel levers as follows.

Steering the machine when stopped

When turning to the left, Push the right travel lever forward to turn to the left when traveling forward; and pull it back to turn left when traveling in reverse.

(A): Forward left turn

(B): Reverse left turn

REMARK

When turning to the right, operate the left travel lever in the same way.

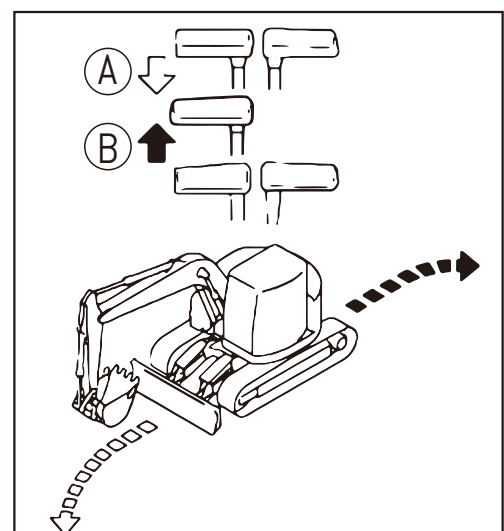

Changing direction of the machine when moving straight

When turning to the left:

If the left travel lever is returned to the neutral position, the machine will turn to the left.

(A): Forward left turn

(B): Reverse left turn

REMARK

When turning to the right, operate the right travel lever in the same way.

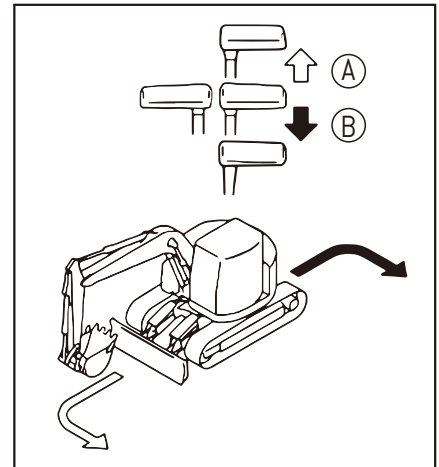

Counter-rotation turn (spin turn)

When rotating to the left, pull the left walking joystick back and push the right walking joystick forward.

REMARK

When using counter-rotation to turn right, pull the right travel lever back and push the left travel lever forward.

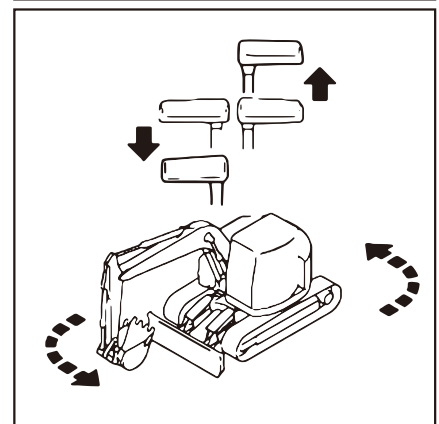

Swinging

WARNING



Before operating the swing, check that the area around the machine is safe.

REMARK

- When swinging on the ramp, you should operate the engine at a low speed and operate the swing control lever at a micro operation
- Especially in the bucket load state, should avoid sudden operation.
- When the bucket is on load, the brake of the parking brake can be released by operating the left work equipment control lever. There will be an instant return, but this is not unusual.

Work Equipment Controls and Operations

WARNING



This operation is only for the standard operation mode (ISO mode). For other operation modes, please contact your dealer.

Use the control levers to operate the work equipment

When the levers are released, they return to the middle position and the work equipment is held in that position.

•Arm operation

Operate the left control lever forward (1) or backward (2) to control the arm.

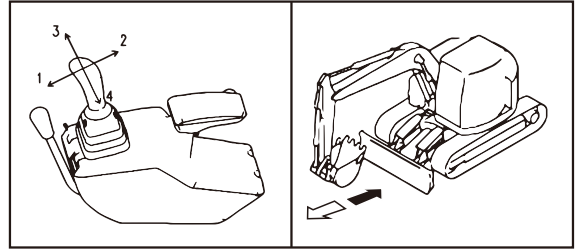

•Swing operation

Operate the left control lever to the left (3) or right (4) to swing the upper structure.

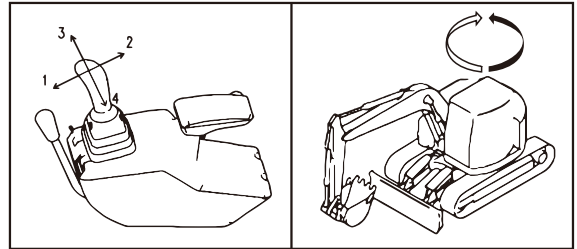

•Boom operation

Operate the right control lever forward (1) or backward (2) to operate the boom.

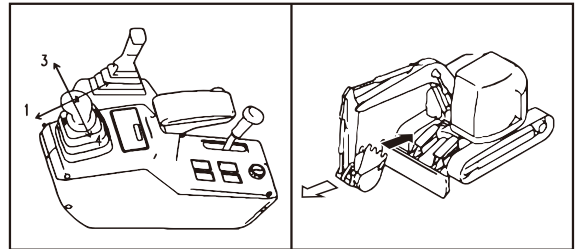

•Bucket operation

Operate the right control lever to the right (3) or left (4) to operate the bucket.

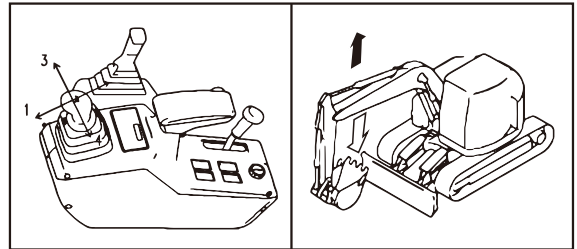

•Blade operation

Move the blade lever forward or backward to operate the blade.

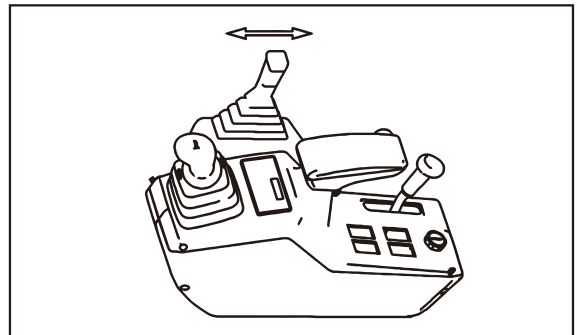

REMARK

When the engine stops, if necessary, lower the working device to the ground or release the residual pressure in the hydraulic circuit and do this as follows.

1. Turn the key to the ON position, lift the safety lock lever to position.
2. Operate the required action, at this time the working device will operate in accordance with the control handle slowly. Move the handle back and forth a few times to release the internal pressure fully.
3. Turn the key to the OFF position, put down the safety lock lever.

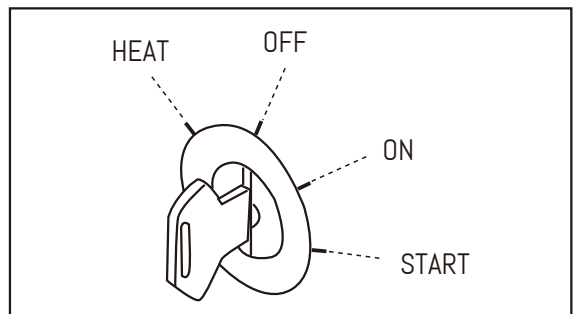

REMARK

- The control action requires the ability to descend under the action of its own gravity.
- Generally the action can be able to control including a bucket arm eversion, boom down, dozer down.

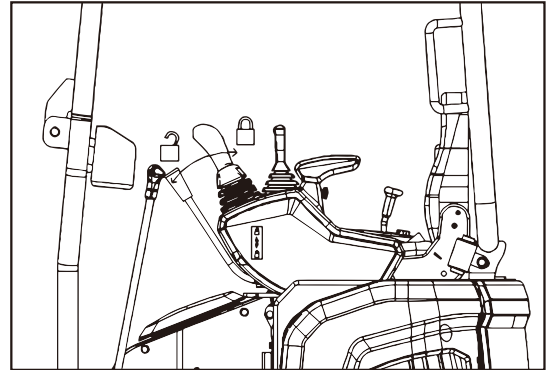

WARNING



When carrying out hydraulic system maintenance (joint hose disassembly and replacement, etc.) must release pressure, otherwise it will cause serious injury.

Operation with Hook Bucket

Precautions for Lifting

- Do not exceed the specified lifting load.
- Use wire rope that conforms to the specified standard.
- Do not carry out lifting work on slopes, soft ground, or other places where the machine is not stable.
- It is dangerous if the raised load is too heavy and shakes. Slow down the engine speed and operate the operating handle slowly.
- Do not start, swing, or stop the machine suddenly. There is a hazard that the lifted load will swing.
- Do not use the work equipment or swing to pull the load in any direction. There is danger that the hook may break and the load come off, causing the work equipment to move suddenly and cause personal injury.
- Do not use two machines together to enhance operations, it is very dangerous.
- Do not leave the operator's seat when there is a raised load.
- Prohibited for pulling pile operation.
- It is dangerous if the raised load hits any person or structure. When swinging or operating the work equipment, check carefully that the surrounding area is safe.
- Do not run the machine while lifting.
- Depending on the work posture, the wire rope and rings may fall off the hook. In order to prevent this, should pay special attention to the angle of the hook.

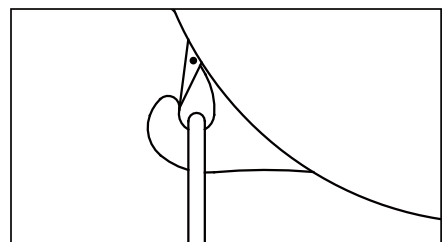
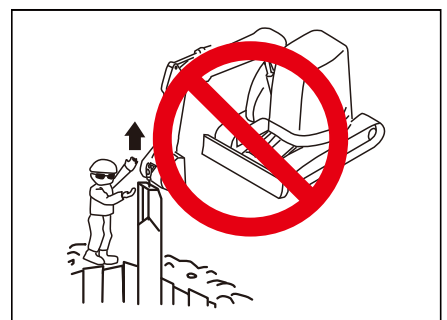

NOTICE

Please do not enter the area under the lifting weight and its surrounding.

- When turning the bucket with a hook, be careful to avoid interference with the boom and the body during bucket unloading.

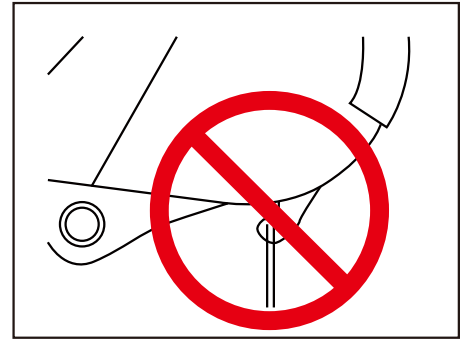

WARNING



This machine bucket with hooks for auxiliary construction use, non-special lifting hooks, Professional lifting hooks must be equipped with anti-off hooks.

Any problems caused by using the machine with its own non-special hook for lifting operation have nothing to do with our company!

If you need special hoisting hook, please contact mechmaxx Distributor.

Prohibited Operations

WARNING



- If it is necessary to operate the working device while the machine is walking, be especially careful when operating.
- If you operate any joystick when the deceleration is in effect, the engine speed will suddenly increase, so be careful when operating.

Operations Using Swing Force

Do not use rotational force to compact the ground or broken objects. And during the turning process, do not dig the bucket teeth into the ground. Doing so will damage the working device.



Operations Using Travel Force

Do not dig the bucket into the ground and use the travel force to carry out excavation. This will damage the machine or work equipment.



Operations Using Stroke Ends of Hydraulic Cylinders

If the work equipment is used with the cylinder rod operated to its stroke end, and given impact by some external force, the hydraulic cylinders will be damaged, causing personal injury. Avoid operations with the hydraulic cylinder fully retracted or fully extended.

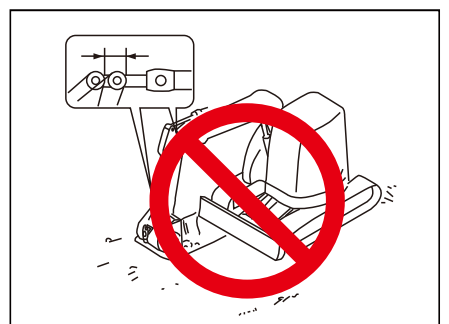

Digging Hard Rocky Ground

It is better to excavate it after breaking up by some other means. This will not only save the machine from damage but will make for better economy.



Operations Using Bucket Dropping Force

Use the descending force of the working device to excavate, use the descending force of the bucket as a pick, or use the bucket for impact excavation or pile driving. Doing so will generate excessive force. In addition to causing damage to the machine, it is also very dangerous, so do not Do this

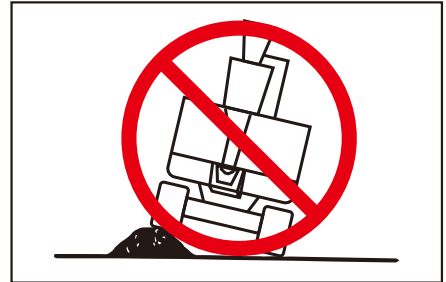

Operations Using Machine Dropping Force

Do not use the descending force of the machine for digging. The hard rocky ground is best broken by other methods first, and then excavated. This will not cause damage to the machine and is more economical. Do not use the descending force of the machine for digging.

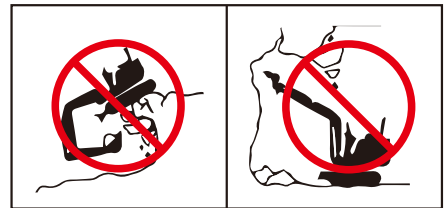

Prohibit Lifting Operations

It is prohibit to use this machine for lifting operations, but it is not restricted when a special lifting hook is installed. Refer to "Operation with Hook Bucket".

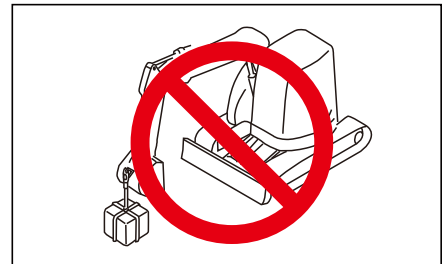

Sustain Blade on Both Sides

Do not sustain the machine with one end of the blade when using blade.

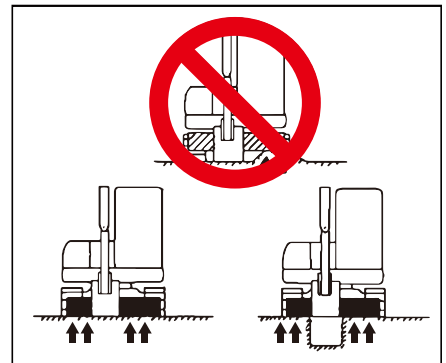

General Operation Information

Traveling

When walking on obstacles (such as gravel, tree stumps), the machine (especially the lower walking device) will withstand a great impact, resulting in damage to the machine. Therefore, such obstacles should be removed as much as possible and avoid walking on obstacles. As a last resort, reduce the walking speed, keep the working device close to the ground, and make the center of the crawler cross over obstacles.

Avoid Blade Impacted

Do not given impact by some stones or road shoulder, this will premature damage the blade or hydraulic cylinders.

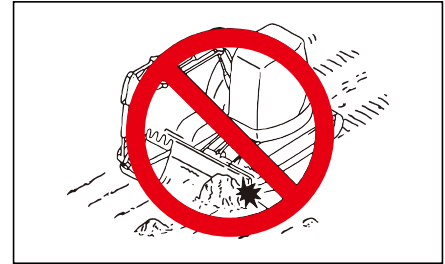

Fold the Work Equipment

Be careful not to allow the bucket to impact the blade when the work equipment is folded in traveling or transport attitude.

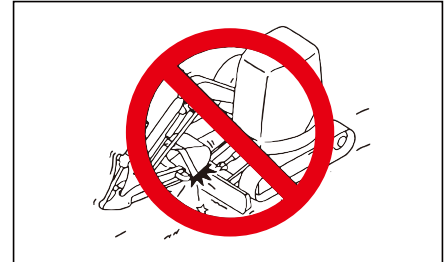

Blade in Backhoe Operation

When the excavator is in deep excavation while the blade is at the front, be careful not to impact the blade with the boom cylinder. In addition to the blade must be in the front, insure put the blade placed in the rear.

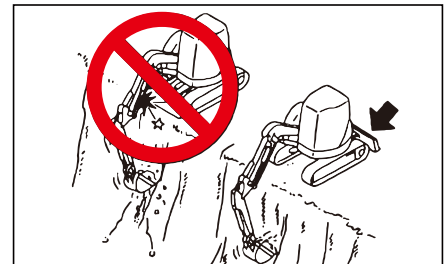

Permissible Depth of Water

WARNING



When driving the machine out of water, if the angle of the machine exceeds 15°, the rear of the upper structure will go under water, and water will be thrown up by the radiator fan. This may cause the fan to break. Be extremely careful when driving the machine out of water.

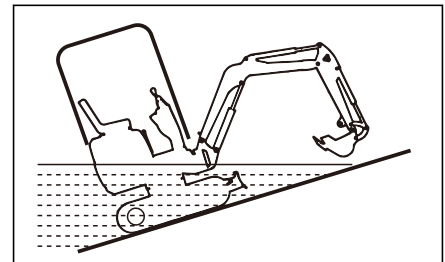

Do not drive the machine in water deeper than the center of carrier roller. Supply grease to the parts which have been under water for a long time until the used grease is projected out of the bearings (around the bucket pin, in particular).

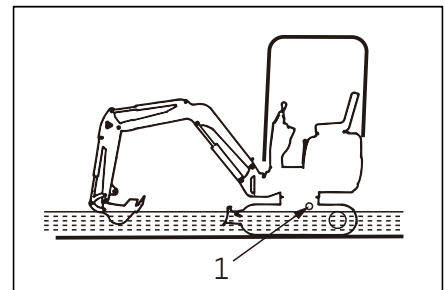

Traveling on Slopes

WARNING



- Turning or operating the work equipment when working on slopes may cause the machine to lose its balance and turn over, so avoid such operations. It is particularly dangerous to swing downhill when the bucket is loaded. If such operations have to be performed, pile soil to make a platform (A) on the slope so the machine is kept horizontal during operation.
- Do not travel up or down steep slopes. There is a danger that the machine may turn over.
- When traveling, raise the bucket approx. 20 to 30 cm from the ground. Do not travel downhill in reverse.
- Never turn on slopes or travel across slopes. Always go down to a flat place to perform these operations. It may be longer, but it will ensure safety.
- Always operate or travel in such a way that it is possible to stop safely at any time if the machine slips or becomes unstable.
- When traveling uphill, if the shoes slip or it is impossible to travel uphill using only the force of the tracks, do not use the pulling force of the arm to help the machine travel uphill. There is danger that the machine may turn over.

1. When traveling down steep hills, use the travel lever and fuel control dial to keep the travel speed low. When traveling down a steep hill of more than 15°, set the work equipment to the posture shown in the diagram on the right and lower the engine speed.

REMARK

When traveling downhill, the sprocket side ① in the downhill side.

If the machine goes downhill, the side of the drive wheel ① is on the uphill side, the crawler tends to

It will relax and cause tooth skipping.

2. When traveling up a steep hill of more than 15°, set the work equipment to the posture shown in the diagram on the right.

Traveling Downhill

Put the travel lever in the middle position. This will cause the brake to be automatically applied.

Engine Stopped on Slope

If the engine stops when traveling uphill, move the travel levers to the middle position, lower the bucket to the ground, stop the machine, then start the engine again.

Notes on Slopes

- Even if the engine is turned off on a slope, if the left working device joystick is used for turning operations, the upper turning platform will turn due to its own weight. Therefore, turning operations must not be performed.

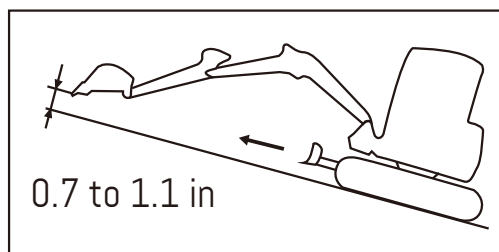
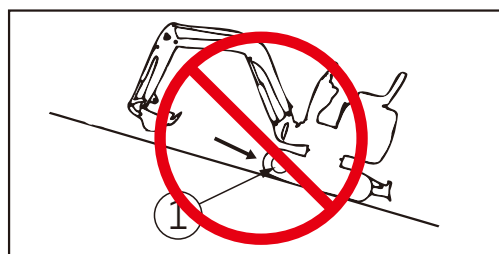
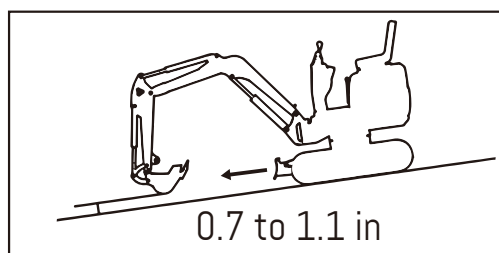
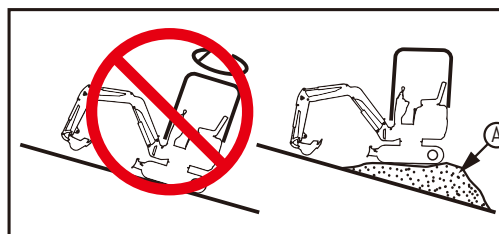
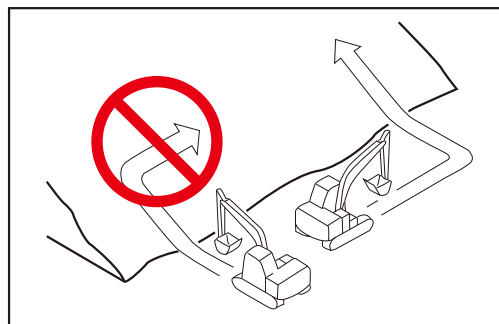

Cold Weather Operation

Cold Weather Operation Information

If the temperature becomes low, it becomes difficult to start the engine, and the coolant may freeze, so do as follows:

Fuel and Lubricants

Change to fuel and oil with low viscosity for all components. For details of the specified viscosity, see "Please use the Recommended Fuel, Oil and Coolant and Water for Dilution".

Cooling System Coolant

WARNING



- Antifreeze is toxic. Be careful not to get it into your eyes or on your skin. If it should get into your eyes or on your skin, wash it off with large amounts of fresh water and see a doctor at once.
- Antifreeze is flammable. Do not bring any flame close. Do not smoke when handling antifreeze.

For details of the antifreeze mixture when changing the coolant, see "Clean inside of Cooling System – Clean/Replace".

Battery

WARNING



- The battery generates flammable gas. Do not bring fire or sparks near the battery.
- Battery electrolyte is dangerous. If it gets in your eyes or on your skin, wash it off with a large amount of water and consult a doctor.
- Battery electrolyte dissolves paint. If it gets on the bodywork, wash it off immediately with water.
- If the battery electrolyte is frozen, do not charge the battery or start the engine with a different power source. There is danger that the battery may explode.
- Battery electrolyte is toxic. Do not let it flow into drainage ditches or spray it on to the ground surface.

When the ambient temperature drops, the capacity of the battery will also drop. If the battery charge ratio is low, the battery electrolyte may freeze. Maintain the battery charge as close as possible to 100%. Insulate it against cold temperature to ensure the machine can be started easily the next morning.

- As the battery capacity drastically drops in low temperatures, cover or remove the battery from the machine, store the battery in a warm place, and install it again the next morning.

After Daily Work Completion

WARNING



- Performing idle-running of the tracks is dangerous, stay well away from the tracks.
- After work completion, fill the fuel tank to capacity. This minimizes moisture condensation in the tank when the temperature drops.

To prevent mud, water, or the undercarriage from freezing and making it impossible for the machine to move on the following morning, observe the following precautions.

- Remove all the mud and water from the machine body. In particular, wipe the hydraulic cylinder rods clean to prevent damage to the seal caused by mud, dirt, or drops of water on the rod from getting inside the seal.
- Park the machine on hard, dry ground.
- If this is impossible, park the machine on boards.
- The boards prevent the tracks from freezing to the ground, and allow the machine to be moved the next morning.
- Open the drain valve and drain any water collected in the fuel system to prevent it from freezing.
- After operation in water or mud, remove water from undercarriage as described below to extend undercarriage service life.

1. Swing 90° with engine at low idle and bring the work equipment to the side of the track.

2. Jack up the machine until the track is raised slightly from the ground. Rotate the track under no load. Repeat this procedure on both the left and right sides.

After Cold Weather Season

When the season changes and the weather becomes warmer, do as follows.

- Replace the fuel and oil for all parts with oil of the viscosity specified.

For details, see "Please use the Recommended Fuel, Oil and Coolant and Water for Dilution".

If for some reason it is not possible to use permanent type coolant, replace it with glycol-based coolant, or if there is no coolant, must clean the cooling system completely, and add fresh soft water.

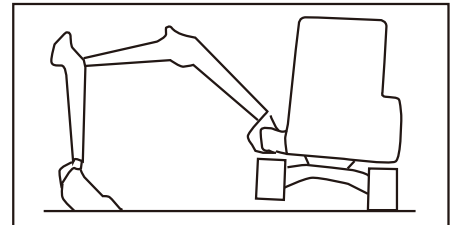

Long Term Storage

Before Storage

NOTICE

When storing the machine (1 month or more), set the machine in the posture shown in the diagram on the right to protect the cylinder rod. (To prevent rusting of the cylinder rod).

When putting the machine in storage for a long time (more than one month), do as follows.

- Clean and wash all parts, then store the machine indoors. If the machine has to be stored outdoors, select level ground and cover the machine with canvas.
- Completely fill the fuel tank. This prevents moisture from collecting.
- Lubricate and change the oil before storage.
- Coat the exposed portion of the hydraulic cylinder piston rod with grease.
- Set the attachment control pedal to the lock position on machines ready for attachments.
- Set the stop valve to the LOCK position on machines ready for attachments. Install the blind plugs to the elbows.

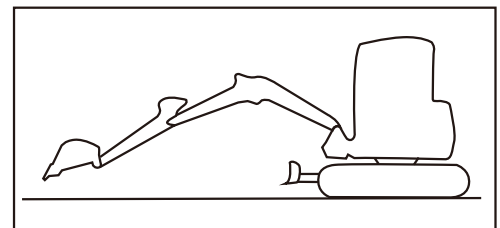

During Storage

WARNING



If it is necessary to perform the rust-prevention operation while the machine is indoors, open the doors and windows to improve ventilation and prevent gas poisoning.

- During storage, operate and move the machine for a short distance once a month so that a new film of oil will coat moving parts. At the same time, also charge the battery.
- When operating the work equipment, wipe off all the grease from the hydraulic cylinder rods.
- If the machine is equipped with an air conditioner, operate the air conditioner for 3 to 5 minutes once a month to lubricate all parts of the air conditioner compressor. Always run the engine at low idle when doing this. In addition, check the refrigerant level twice a year.

After Storage

NOTICE

If the machine has been stored without carrying out the monthly rust-prevention operation, consult your mechmaxx construction machinery distributor before using it.

When using the machine after long-term storage, do as follows before using it.

- Wipe off the grease from the hydraulic cylinder rods.
- Add oil and grease at all lubrication points.
- When the machine is stored for a long period, moisture in the air will mix with the oil. Check the oil before and after starting the engine. If there is water in the oil, change all the oil.
- Turn on the battery circuit breaker. The operation method refers to "battery circuit breaker".

Troubles and Actions

Running out of Fuel

When starting the engine again after running out of fuel, fill with fuel, then bleed the air from the fuel system before starting the engine.

For details, see "Air Bleeding of Fuel System"

Phenomena that are not Failures

Note that the following phenomena are not failures:

- When the arm control lever is operated to the IN position and the work equipment is lowered under no load from a high position, the arm speed will drop momentarily when the arm is more or less at the vertical position.
- When the bucket control lever is operated to the CURL position and the work equipment is lowered under no load from a high position, the bucket speed will drop momentarily when the bucket teeth are more or less at the horizontal position. The bucket or arm will fluctuate by itself during heavy-duty digging operations.

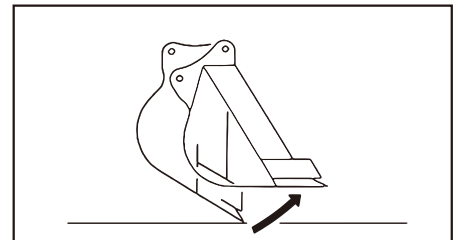
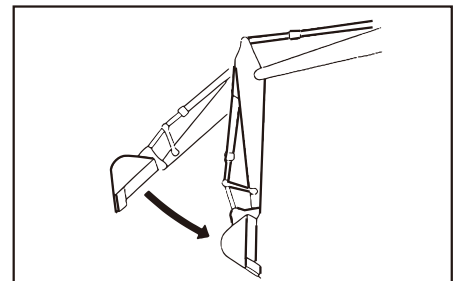

- When starting or stopping the swing, noise will be emitted from the brake valve.
- When going down a steep slope at low speed, a noise will be emitted from the travel motor brake valve.

Towing the Machine

WARNING



- Always check that the wire rope used for towing has ample strength for the weight of the machine being towed.
- Operate the machine slowly and be careful not to apply any sudden load to the wire rope.

If the machine sinks in mud and cannot get out under its own power, or if the drawbar pull of the excavator is being used to tow a heavy object, use a wire rope as shown in the diagram on the right.

Place pieces of wood between wire ropes and body to prevent damage to ropes and body.

Hold the wire rope level and direct it straight to the track frame.

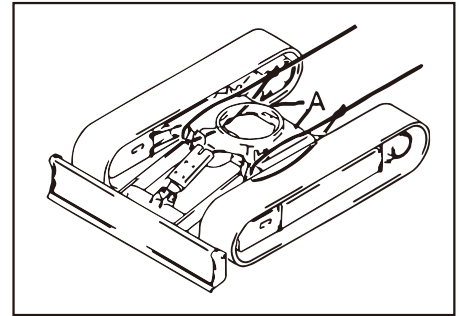

Lightweight Towing Hole

WARNING



- When use A hook rings, the traction load must be light, otherwise it is easy to damage the crawler frame.
- Hold the wire rope level and direct it straight to the track frame.
- Move the machine slowly and be careful not to apply any sudden load to the wire rope.

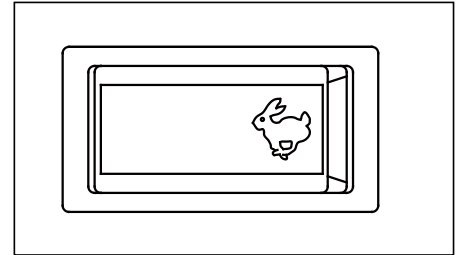

There is one hole in the track frame to fit the shackle when towing light objects.

Severe Job Condition

- When carrying out digging operations in water, if the work equipment mounting pin goes into the water, carry out greasing at the position A、B、C、D and every time the operation is carried out.
- For heavy-duty operations and deep digging, carry out greasing of the work equipment mounting pins A、B、C、D and E every time before operation.

After greasing, operate the boom, arm and bucket several times, then grease again.

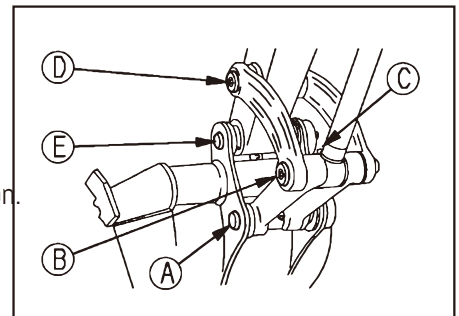

Battery Discharges and Charges

WARNING



- It is dangerous to charge a battery when mounted on a machine. Make sure that it is dismantled before charging.
- When checking or handling the battery, stop the engine and turn the starting switch key to the OFF position.
- The battery generates hydrogen gas, so there is a hazard of explosion. Do not bring lighted cigarettes near the battery, or do anything that will cause sparks.
- When handling batteries, always wear safety glasses and rubber gloves.
- Battery electrolyte is dilute sulfuric acid, and it will attack your clothes and skin. If it gets on your clothes or on your skin, immediately wash it off with a large amount of water. If it gets in your eyes, wash it out with fresh water and consult a doctor.

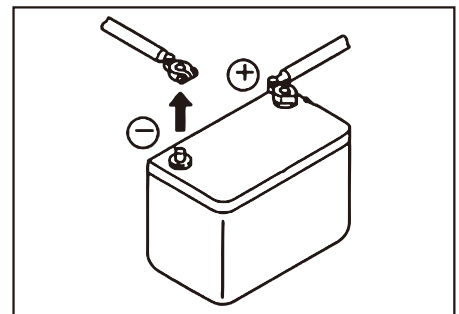
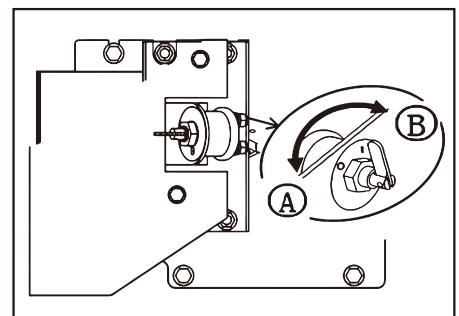

WARNING

- When removing the battery, first disconnect the cable from the ground (normally the negative (-) terminal). When installing, install the positive (+) terminal first. If a tool touches the positive terminal and the chassis, there is danger that it will cause a spark, so be extremely careful.
- If the terminals are loose, there is danger that the defective contact may generate sparks that will cause an explosion.
- When removing or installing the terminals, check which is the positive(+) terminal and which is the negative (-) terminal.

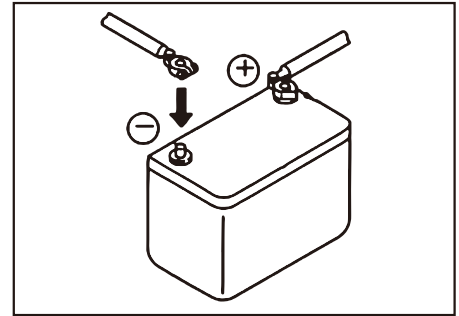
**Battery Removal and Installation****NOTICE**

After installing the battery in place, check whether the battery is moving. If moving and re-tighten it.

- Open the left hood.
- When removing the battery, first disconnect the cable from the ground (normally the negative (-) terminal).
- If a tool touches the positive terminal and the chassis, there is danger that it will cause a spark, so be extremely careful.
- Then remove six bolts and three screws, you can remove the battery.
- When installing the battery, connect the ground cable last.
- When replacing the battery, secure it with battery hold-down.

Additional Electric Battery

Before cars started, the car with electric start time is too long and abnormal use, because of leakage and long car stops, the vehicle or the vehicle charging generator failure, the battery can't normal charging battery loss caused by electricity, battery electric eye blackened, even can't start the car. The battery need to supplement by electricity.

Check the battery status indicator (wink), power display:

Green: the battery power is enough, can normal boot excavator.

Black: deficiency of battery, the battery should be added.

White: battery needs replacement.

1. Once inspection before charging

- Do not charge the battery if the shell burst or it leaks acid, replace the battery after finding out the reason.
- Do not charge the battery if its end column burst, replace the battery after finding out the reason.
- Do not charge the battery if the electric eye is white and replace the battery

Do not charge the inflation bulging battery caused by over-discharge or overcharge and replace the battery

- Clean the end column and remove the surface scale before charge the battery.

2. When charging the battery we must know

- Wearing glasses.
- Maintain environmental ventilation when charging, charging under normal temperature.
- No smoking when charging, and avoid the introduction of the flame.
- After charging connection, first connect the positive attachment; Take out stitches before charging, disconnect the cathode attachment first.

3. Battery charging

- Connect the positive (+) charger clip of the charger to the positive (+) terminal of the battery, then connect the negative (-) charger clip of the charger to the negative (-) terminal of the battery.
- Make sure the battery is clean and the charging circuit is well connected.
- Recommended use constant voltage 16.0 volts (maximum can not exceed 16.2 volts, the charging current does not exceed 25A) charger to charge battery until the electric eye turns green. The battery is fully charged when the eye turns green.
- IF there is not a constant voltage way to charge, according to the following specifications constant current charging:
- Charging current(A)=C20/10.(C20 --- 20 hours rate capacity)

Note: If more than one battery is charged in parallel, the current values are summed.

Charging time and battery voltage corresponding relationship (reference)

Battery voltage	12.55~ 12.45V	12.45~ 12.35V	12.35~ 12.20V	12.20~ 12.05V	12.05~ 11.95V	11.95~ 11.80V	11.80~ 11.65V	11.65~ 11.50V	11.50~ 11.30V	11.30~ 11.00V	bellow 11.00V
Charging time	2 hours	3 hours	4 hours	5 hours	6 hours	7 hours	8 hours	9 hours	10 hours	12 hours	14 hours

- After charging, check the color of the accumulator's eye. The electro-optic display is green, indicating that the battery is fully charged. If the eye is black, check whether the charging connection is secured, whether the connection point is clean, and continue to replenish the electricity until the eye appears green. For batteries whose battery voltage is less than 11.0V, the phenomenon of battery charging out may occur in the initial stage of replenishment. Because of the serious shortage of batteries, the proportion of sulfuric acid in the batteries has approached pure water, and the internal resistance of the batteries is very large. With the charging of the batteries, the proportion of sulfuric acid in the batteries increases, and the charging current of the batteries can gradually return to normal.
- During charging process, if the battery exhaust hole vent acid, should stop charging immediately.
- During charging process, check the battery eye color every hour. The battery is fully charged when the eye turns green, then stop charging.

Starting Engine with Booster Cables

When starting the engine with a booster cable, do as follows:

Connecting and Disconnecting Booster Cables

WARNING



- When connecting the cables, never contact the positive (+) and negative (-) terminals.
- When starting the engine with a booster cable, always wear safety glasses.
- Be careful not to let the normal machine and problem machine contact each other. This prevents sparks from generating near the battery which could ignite the hydrogen gas given off by the battery. If hydrogen gas explodes, it could cause serious injury.
- Be careful not to make a mistake when connecting a booster cable. In the last connection (to the upper structure frame), a spark will be caused, connect the cable to a spot as far away from the battery as possible. (Avoid the work equipment, however, because it is not a good conductor)
- When removing the booster cable, exercise good care so that the booster cable clips may not contact each other, or they contact the chassis.

NOTICE

- The starting system for this machine uses 12V. For the normal machine, also use a 12V battery.
- The size of the booster cable and clip should be suitable for the battery size.
- The battery of the normal machine must be the same capacity as that of the engine to be started.
- Check the cables and clips for damage or corrosion.
- Make sure that the cables and clips are firmly connected.
- Check that the lock levers and parking brake levers of both machines are in the LOCK position.
- Check that each lever is in the NEUTRAL position.

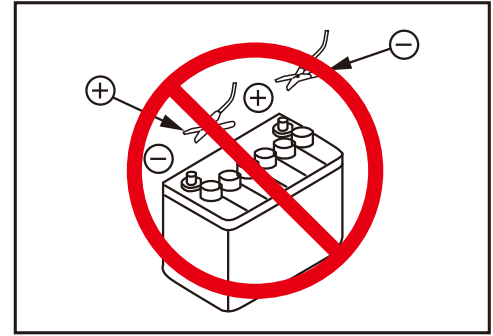

Booster Cable Connection

Keep the starting switch of the normal machine and problem machine in the OFF position.

1. Connect the booster cable as follows, in the order of the numbers marked in the diagram.
2. Connect the clip of booster cable (A) to the positive (+) terminal of battery on the problem machine.
3. Connect the clip at the other end of booster cable (A) to the positive (+) terminal of battery on the normal machine.
4. Connect the clip of booster cable (B) to the negative (-) terminal of battery on the normal machine. Connect the other clip of booster cable (B) to the revolving frame of the problem machine.

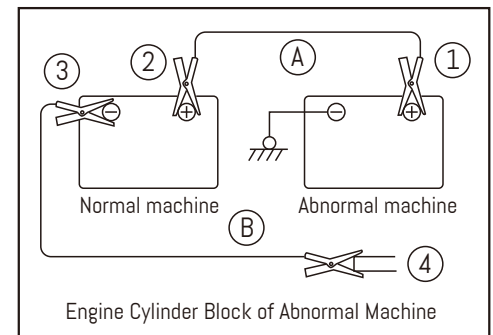

Starting the Engine

WARNING



Always check that the lock lever is set to the LOCK position, regardless of whether the machine is working normally or has failed. Check also that all the control levers are in the HOLD or neutral position.

1. Make sure the clips are firmly connected to the battery terminals.
2. Start engine of the normal machine and run it at high idle speed.
3. Turn the starting switch of the problem machine to the START position and start the engine. If the engine doesn't start at first, try again after 2 minutes or so.

Booster Cable Disconnection

After the engine has started, disconnect booster cables in the reverse order in which they were connected.

1. Remove one clip of booster cable (B) from the revolving frame of the problem machine.
 2. Remove the clip of booster cable (B) from the negative (-) terminal of battery on the normal machine.
 3. Remove the clip of booster cable (A) from the positive (+) terminal of battery on the normal machine.
- Remove the clip of booster cable (A) from the positive (+) terminal of battery on the problem machine.

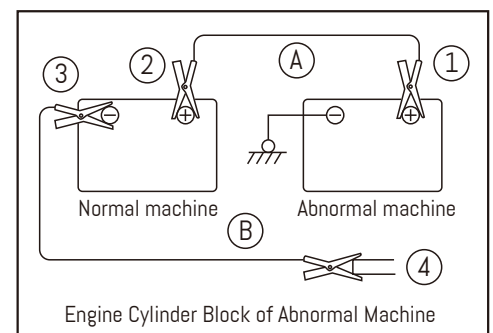

Others Malfunction

Chassis

- In case of problems or causes which are not listed below, contact your mechmaxx distributor.

Problem	Main causes	Remedy
Speed of travel, swing, boom, arm, bucket is low	Lack of hydraulic oil	Add oil to specified level, see Maintenance
Pump generates abnormal noise	Clogged element in hydraulic	Clean, see Maintenance
Excessive rise in hydraulic oil temperature	Loosen fan belt Dirty oil cooler Lack of hydraulic oil	Check and adjust fan belt tension, see Maintenance Clean, see Maintenance Add oil to specified level, see Maintenance
Track comes off	Track too loose	Adjust track tension, see Maintenance
Abnormal wear of sprocket		
Boom rises slowly, does not rise	Lack of hydraulic oil	Add oil to specified level, see Maintenance

Electrical System

- When dealing with these projects, please contact the mechmaxx dealer.
- If there are not listed in the table below the fault or reason, please contact the dealer for repair.

Hitch	Main cause	Resolvent
Even if the engine is running at high speed, the lighting is not bright.	Lead failure Belt tension adjustment error	(Check and repair the loose terminals.)
When the engine is running, the lights flicker		Adjust fan belt tension, see every 1000 hours of maintenance
Even when the engine is running, the charge monitor does not go out.	AC generator fault Lead failure	(replace) (Check and repair)
AC generator generates abnormal noise	AC generator fault	(replace)
When the starting switch is switched to ON, the starting motor does not work.	Lead failure Starting motor fault Battery charging problem Safety relay fault	(Check and repair) (replace) Charge (replace)
Starting motor pinion to keep running	Battery charging problem Starting motor fault	Charge (replace)
Start motor slowly rotating engine	Battery charging problem Starting motor fault	Charge (replace)
Before starting the engine, motor starting off	Lead failure Battery charging problem	Check and repair Charge

Engine

- Always contact your mechmaxx distributor when dealing with these items.
- In cases of problems or causes which are not listed below, contact your mechmaxx distributor for repairs.

Problem	Main causes	Remedy
Engine oil pressure monitor lights up	<ul style="list-style-type: none"> • Engine oil pan oil level is low (sucking in air) • Clogged oil filter cartridge • Defective tightening of oil pipe, pipe joint, oil leakage from damaged point • Defective engine oil pressure sensor • Defective monitor 	<ul style="list-style-type: none"> • Add oil to specified level, see CHECK BEFORE STARTING • Replace cartridge, see EVERY 500 HOURS SERVICE • (Check, repair) • (Replace)
Steam spurts out from top of radiator (pressure valve)	<ul style="list-style-type: none"> • Coolant level low, leakage of water • Dirt or scale accumulated in cooling system • Clogged radiator fins or damaged fins • Defective thermostat 	<ul style="list-style-type: none"> • Check, add coolant, repair • Change coolant, flush inside of cooling system, • (Replace thermostat)
Radiator coolant level monitor lights up	<ul style="list-style-type: none"> • Loose radiator filler cap (high-altitude operations) • Defective water level sensor 	<ul style="list-style-type: none"> • Tighten cap or replace packing • (Replace sensor)
Even after long hours of operation, radiator coolant level monitor lights up	<ul style="list-style-type: none"> • Defective thermostat 	<ul style="list-style-type: none"> • (Replace thermostat)
Engine does not start when starting motor is turned	<ul style="list-style-type: none"> • Lack of fuel • Air in fuel system • Defective fuel injection pump or defective nozzle • Starting motor cranks engine sluggishly • Engine pre-heating monitor does not light up • Defective compression 	<ul style="list-style-type: none"> • Add fuel, see CHECK BEFORE STARTING • Repair place where air is sucked in • (Replace pump or nozzle) • See ELECTRICAL SYSTEM • See ELECTRICAL SYSTEM • (Adjust valve clearance)
Exhaust gas is white or blue	<ul style="list-style-type: none"> • Too much oil in oil pan • Improper fuel • Start the engine suddenly accelerated in the cold days 	<ul style="list-style-type: none"> • Set oil to specified level, see CHECK BEFORE STARTING • Change to specified fuel • Avoid suddenly acceleration before the warm-up operation is completed
Exhaust gas occasionally turns black	<ul style="list-style-type: none"> • Clogged air cleaner element • Defective nozzle • Defective compression 	<ul style="list-style-type: none"> • Clean or replace • (Replace nozzle) • (See defective compression above)
Combustion noise occasionally make breathing sound	<ul style="list-style-type: none"> • Defective nozzle 	<ul style="list-style-type: none"> • (Replace nozzle)

Problem	Main causes	Remedy
Abnormal noise generated (combustion or mechanical)	<ul style="list-style-type: none">• Low-grade fuel being used• Overheating• Damage inside muffler• Excessive valve clearance	<ul style="list-style-type: none">• Change to specified fuel• Refer to "Radiator coolant level monitor lights up" as above• Replace muffler• (Adjust valve clearance)
The engine stops when operating	<ul style="list-style-type: none">• Clogged fuel cleaner element• Defective engine or defective fuel line	<ul style="list-style-type: none">• Replace• (Check, repair)

MAINTENANCE

WARNING

Please read and make sure that you understand the **SAFETY** section before reading this section.

Maintenance Information

Do not perform any inspection and maintenance operation that is not found in this manual.

Service Meter Reading

Check the service meter reading every day to see if the time has come for any necessary maintenance to be performed.

Fresh and Clean Lubricants

Use clean oil and grease. Also, keep the containers of the oil and grease clean. Keep foreign materials away from oil and grease.

Check Drained Oil and Used Filter

After oil is changed or filters are replaced, check the old oil and filters for metal particles and foreign materials. If large quantity of metal particles or foreign materials are found, always report to the person in charge, and carry out suitable action.

Fuel Strainer

If your machine is equipped with a fuel strainer, do not remove it while fueling.

Welding Instructions

- Cut off power. Wait for approx. one minute after turning off the engine starting switch key, and then disconnect the negative (-) terminal of the battery.
- Do not apply more than 200 V continuously.
- Connect grounding cable within 1 m (3.3 ft) of the area to be welded. If grounding cable is connected near instruments, connectors, etc., the instruments may malfunction.
- If a seal or bearing happens to come between the part being welded and grounding point, change the grounding point to avoid such parts.

NOTE

Do not use the area around the work equipment pins or the hydraulic cylinders as the grounding point.

Do not Drop Things Inside Machine

- When opening inspection windows or the oil filler port of the tank to carry out inspection, be careful not to drop nuts, bolts or tools inside the machine.
- If such things are dropped inside the machine, it may cause damage and/or malfunction of the machine, and will lead to failure. If you drop anything inside the machine, always remove it immediately.
- Do not put unnecessary things in your pockets. Carry only things which are necessary for inspection.

Dusty Jobsite

When working at dusty worksites, do as follows:

- Clean the radiator fins and other parts of the heat exchange equipment more frequently, and take care not to let the fins become clogged.
- Replace the fuel filter more frequently.
- Clean electrical components, especially the starting motor and alternator, to avoid accumulation of dust.

- When checking and replacing the oil or filters, move the machine to a place where there is no dust and take care
- To prevent dust from entering the system.

Avoid Mixing Lubricants

If a different brand or grade of oil has to be added, drain the old oil and replace all the oil with the new brand or grade of oil. Never mix different brand or grade of oil.

Locking the Inspection Covers

Lock inspection cover securely into position with the lock bar. If inspection or maintenance is performed with inspection cover not locked in position, there is a danger that it may be suddenly blow shut by the wind and cause injury to the worker.

Hydraulic System - Air Bleeding

When hydraulic equipment has been repaired or replaced, or the hydraulic piping has been removed and installed again, the air must be bled from the circuit.

Hydraulic Hose Installation

- When removing parts at locations where there are O-rings or gasket seals, clean the mounting surface, and replace with new parts. When doing this, be careful not to forget to assemble the O-rings and gaskets.
- When installing the hoses, do not twist them or bend them sharply. If they are installed so, their service life will be shortened extremely and they may be damaged.

Checks After Inspection and Maintenance Works

If you forget to perform the checks after inspection and maintenance, unexpected problems may occur, and this may lead to serious injury or property damage. Always do the following:

Checks after operation (with engine stopped)

- Have any inspection and maintenance points been forgotten?
- Have all inspection and maintenance items been performed correctly?
- Have any tools or parts been dropped inside the machine? It is particularly dangerous if parts are dropped inside the machine and get caught in the lever linkage mechanism.
- Are there any leakages of coolant or oil? Have all nuts and bolts been tightened?

Checks when operating engine

- For details of the checks when operating the engine, see "Maintenance of the Engine" and pay careful attention to safety.
- Are the inspection and maintenance items working properly? Is there any leakage of fuel or oil when the engine speed is raised?

Lubricants, Fuels and Coolants

Lubricants

- Oil is used in the engine and hydraulic equipment under extremely severe conditions (high temperature, high pressure), and deteriorates with use.
- Always use oil that matches the grade and maximum and minimum ambient temperatures recommended in the Operator's Manual. Even if the oil is not dirty, always change the oil at the specified interval.
- Oil corresponds to blood in the human body, always be careful when handling it to prevent any impurities (water, metal particles, dirt, etc.) from getting in. When storing or adding oil, take special care not to let any impurities in.
- Never mix oils of different grades or brands.
- Always add the specified amount of oil. Having too much oil or too little oil are both causes of problems.
- If the oil in the work equipment is not clear, there is probably water or air getting into the circuit. In such cases, please contact your mechmaxx distributor.

- When changing the oil, always replace the related filters at the same time.
- We recommend you have an analysis made of the oil periodically to check the condition of the machine.
- When using commercially available oil, it may be necessary to reduce the oil change interval.

Fuel

- The fuel pump is a precision instrument, and if fuel containing water or dirt is used, it cannot work properly.
- Be extremely careful not to let impurities get in when storing or adding fuel.
- Always use the fuel specified for the temperature in the Operator's Manual.
- If the fuel is used at temperatures lower than the specified temperature (particularly at temperatures below -15°C (5°F), the fuel will solidify.
- To prevent moisture in the air from condensing into water in the fuel tank, fill the fuel tank at the end of each day's work.
- Before starting the engine, or when 10 minutes have passed after adding fuel, drain the sediment and water from the fuel tank.
- If the engine runs out of fuel, or if the filters have been replaced, it is necessary to bleed the air from the circuit.

Storing Oil and Fuel

- Keep indoors to prevent any water, dirt, or other impurities from getting in.
- When keeping drum cans for a long period, put the drum on its side so that the filler port of the drums is at the side to prevent moisture from being sucked in.
- If drums have to be stored outside, cover them with a waterproof sheet or take other measures to protect them.
- To prevent any change in quality during long-term storage, be sure to use in the order of first in - first out (use the oldest oil or fuel first).

Grease

- Grease is used to prevent seizure and noises at the joints.
- This construction equipment is used under heavy-duty conditions. Always use the recommended grease and follow the change intervals and recommended ambient temperatures given in this Operator's Manual.
- The nipples not included in the maintenance section are nipples for overhaul, so they do not need grease. If any part becomes stiff after being used for long time, add grease.
- If any part becomes stiff after being used for long time, add grease.
- Always wipe off all of the old grease that is pushed out when greasing.
- Always wipe off all of the old grease that is pushed out when greasing.
- Be particularly careful to wipe off the old grease in places where sand or dirt sticking in the grease would cause wear of the rotating parts.

Coolant of the cooling system

- When diluting the antifreeze coolant, use distilled water or tap water (soft water). Natural water, such as a river water or well water (hard water), contains large amounts of minerals (calcium, magnesium, etc.), and this makes it easier for scale to form inside the engine or radiator. Once scale is deposited inside the engine or radiator, it is extremely difficult to remove. It also causes overheating due to poor heat exchange.
- When using antifreeze, always observe the precautions given in the Operation and Maintenance Manual.
- Antifreeze coolant is flammable, so be sure to keep it away from flame.
- The ratio of coolant to water differs according to the ambient temperature.
- If the engine overheats, wait for the engine to cool before adding coolant.
- If the coolant level is low, it will cause overheating, and will also cause problems with corrosion due to air entering the coolant.

Filters

- Filters are extremely important safety parts. They prevent impurities in the fuel and air circuits from entering important equipment and causing problems.

Replace all filters periodically. For details, refer to the operation and maintenance manual.

- However, when working in severe conditions, replace the filters at shorter intervals according to the oil and fuel (sulfur content) being used.
- Never try to clean the filters (cartridge type) and use them again. Always replace with new filters.
- When replacing oil filters, check if any metal particles are attached to the old filter. If any metal particles are found, contact your mechmaxx distributor.
- Do not open packs of spare filters until just before they are to be used.

Electric System Maintenance

- It is extremely dangerous if the electrical equipment becomes wet or the covering of the wiring is damaged. This will cause an electrical short circuit and may lead to malfunction of the machine. Do not wash the inside of the operator's cab with water. When washing the machine, be careful not to let water get into the electrical components.
- Service relating to the electric system is checking fan belt tension, checking damage or wear to the fan belt and checking battery fluid level.
- External electron-magnetic interference may cause malfunction of the control system controller, before installing a radio receiver or other wireless equipment, contact your mechmaxx distributor.
- When working at the seashore, carefully clean the electric system to prevent corrosion.
- When installing electrical equipment, connect it to the special power source connector.
- Do not connect the optional power source to the fuse, starting switch, or battery relay.

Maintenance of Hydraulic System

- The hydraulic device is in high temperature during and after operation. In addition, due to the high pressure in the process of operation, the following matters should be noted during the inspection and maintenance of the hydraulic device:
- Leave the machine in a flat place so that the bucket is completely lowered to the ground, and check and maintain it without pressure applied to the oil path of the cylinder.
- Be sure to stop the engine
- After the operation, the hydraulic oil and lubricating oil are still in the state of high temperature and high pressure, and the maintenance can only be carried out after the oil temperature of each part drops.
- Sometimes even though the temperature has dropped, the internal pressure is still there. The internal pressure should be released before maintenance. At the same time, slowly loosen the screw plug, screw and screw loose pipe joint, avoid the front of the body, and remove it while releasing internal pressure.
- During the inspection and maintenance of the hydraulic oil circuit, please be sure to discharge the air in the hydraulic tank and release the internal pressure.
- Inspection and maintenance includes inspection of hydraulic oil level, filter and replacement of hydraulic oil. When removing the high pressure hose, be careful not to damage the o-ring. If there is any damage, please replace it.
- When replacing and cleaning the filter element and screen of the hydraulic oil filter, when repairing, replacing and removing the hydraulic piping of the hydraulic device, air shall be discharged from the oil path.

Wear Parts

- Replace wear parts such as the filter element or air cleaner element at the time of periodic maintenance or before they reach the wear limit.
- The wear parts should be replaced correctly in order to ensure more economic use of the machine.
- When ordering parts, check the part number in the parts catalog.

Wear Parts List

(The parts in parentheses are to be replaced at the same time)

Item	Part No.	Part Name	Q'ty	Replacement frequency	
Oil filter	60017-03-00016	Oil filte	1	First 50 hours Every 250 hours	MEC17
Hydraulic oil filter	60017-78-00035	Hydraulic return filter	1	Every 1000 hours	MEC17
Fuel filter	60017-03-00012 60017-03-00022	Fuel pre-filter element Fuel oil fine filter	1	Every 500 hours	MEC17
Guide cartridge	60017-84-00024	Guide cartridge	1	First 500 hours Every 1000 hours	MEC17
Air cleaner	60017-07-00005 60017-07-00004	Main element Safety element	1 1	After six times every 1000 hours	
Bucket	60017-63-00014	Tooth (pin)	3	-	
	60017-63-00012 60017-63-00013	Side of the blade gasket gasket (pin)	1 1	-	
Plow	60017-53-00011	Knife plate (welding)	1	-	

Notice: Actual replacement frequency accord to Maintenance schedule.

Use the Recommended Fuel, Coolant and Lubricants

- Failure to use the recommended product can result in shortened life and excessive wear of engines, drivetrains, cooling systems and other components.
- Select and use the oils and grades recommended in the table below according to ambient temperature.
- Under 32°F when you start the engine, even if the temperature has risen to more than 32°F temperature, also be sure to use more than the recommended grade engine oil.
- When refueling, the filter should be removed from the refueling port first, and then be cleaned with clean diesel oil and put back to the refueling port before refueling.
- The addition of oil and grease should meet the requirements, not too much or too little.
- The appliance that refuels, water must be clean, store in the box that covers tightly after using or cabinet.
- When the discharge of oil will make the oil temperature preheating to 86 ~ 140 °F advisable

Correct Selection

Location	Species	Ambient temperature								
		-22 -30	-4 -20	14 -10	32 0	50 10	68 20	86 30	104 40	122°F 50°C
Engine lubrication	Engine oil	SAE 10W								
		SAE 10W-30								
		SAE 15W-40								
						SAE 30				
						SAE 40				
Hydraulic tank	Mineral oil	ISO VG46								
						ISO VG68				
Swing drive	Gear oil	SAE 85W-140 or API GL-5								
Travel drive	Gear oil	SAE 80W-90 or API GL-5								
Fuel tank	Diesel fuel	-35#								
						10#				
						0# or 5#				
Grease fitting	Grease	Molybdenum disulfide NLG12								
Cooling system	Antifreeze	-45#								
						-35#				

•Please buy genuine oil from distributor, in order to ensure the quality of oil.

Notice:

SAE: Society of Automotive Engineers

ISO: International Organization for Standardization

API: American Petroleum Institute

Tightening Torque Specifications

WARNING



- If nuts, bolts, or other parts are not tightened to the specified torque, it will cause looseness or damage to the tightened parts, and this will cause failure of the machine or problems with operation.
- Always pay careful attention when tightening parts.

Unless otherwise specified, tighten the metric nuts and bolts to the torque shown in the table below.
If it is necessary to replace any nut or bolt, always use a mechmaxx genuine part of the same size as the part that was replaced.

Tightening Torque List

Thread diameter	Across flats S/mm	Tightening torque: [N·m (Kgf·m)]	
		Extent	Target
M6	10	11.8 ~ 14.7	13.2
M8	13	27 ~ 34	31.4
M10	16	59 ~ 74	65.7
M12	18	98 ~ 123	112.7
M14	21	157 ~ 196	176
M16	24	245 ~ 309	279
M18	27	343 ~ 427	382
M20	30	490 ~ 608	549
M22	34	662 ~ 829	745
M24	36	824 ~ 1030	927
M27	41	1180 ~ 1470	1323

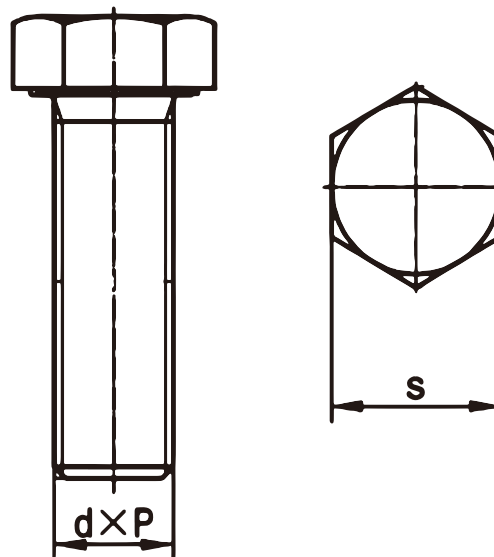

Apply the following table for Hydraulic Hose :

Nominal number	Thread Diameter M	Width across Flats S	Target value	Extent
L ^a	M12X1.5	14	16	15-17
	M14X1.5	17	16	15-17
	M16X1.5	19	26	25-28
	M18X1.5	22	37	35-39
	M22X1.5	27	47	45-50
	M26X1.5	32	89	85-94
S ^a	M22X1.2	27	79	75-83
	M24X1.5	30	84	80-88

Notice:

L^a: Light series connector , S^a: Heavy series connector , see ISO8434-1 for the distinction of weight series.

Regular Replacement of Safety Critical Parts

- To ensure safety, the user must perform regular maintenance on the machine when operating or driving the machine. In addition, in order to further improve safety, users should also periodically replace parts in the safety critical parts list. These parts have a particularly close relationship to safety and fire protection, so please contact your mechmaxx for replacement.
- For these parts, the material changes over time and they are prone to wear or deterioration. However, it is difficult to completely judge the condition of the parts through regular maintenance. Therefore, the specified time is up, regardless of the situation, it must be replaced. This is necessary to ensure that these parts always maintain their function completely.
- If these parts have not returned to the replacement cycle, they must be repaired or replaced immediately.
- If the hose clamp deteriorates, such as deformation or cracks, replace the hose clamp while replacing the hose.
- The following checks should be performed on hydraulic hoses that are not listed as regular replacement parts. If abnormalities are found, tighten or replace them.
- When replacing the hose, replace the O-ring, gasket and other similar parts at the same time.

Safety critical parts

Number	Part Name	Q'ty	Replacement frequency
1	Fuel hose (fuel tank - fuel pre-filter)	1	Every 2 years or 3000 hours, whichever comes first
2	Fuel hose (fuel pre-filter - fuel fine filter)	1	
3	Fuel hose (fuel fine filter - engine)	1	
4	Fuel return pipe (engine - fuel tank)	1	
5	Hydraulic hose (pump drain)	1	
6	Hydraulic hose (pump return)	1	
7	Hydraulic hose (boom cylinder - control valve)	4	
8	Hydraulic hose (arm cylinder - control valve)	2	
9	Hydraulic hose (bucket cylinder - control valve)	4	
10	Hydraulic hose (swing motor - control valve)	2	
11	seat belt	1	Every 2 years

Maintenance schedule

If the machine is equipped with hydraulic hammer, the maintenance schedule of some parts is different. For details, see "Maintenance Cycle when Using hydraulic hammer" to determine the correct maintenance schedule when performing maintenance.

Maintenance schedule

Maintenance schedule and procedures refer to the maintenance Table, which is pasted on the vehicle.

Check before operation

For details of the following items, see "Pre-job inspection" in the operations section.

- Cooling system coolant level - check/fill
- Engine oil level - check/fill
- Fuel oil level - check/fill
- Air filter dust indicator - check
- Hydraulic oil level - check/fill
- Electrical wiring - Inspection
- Horn function - check

Irregular maintenance

- Air filter element - inspection/cleaning
- Internal cleaning of cooling system - cleaning/replacement
- Water and sediment in the fuel prefilter - discharge
- Water and sediment in fuel tank - discharge
- Track tension - check/adjust (machine with metal track board, road liner)
- Bucket teeth - replacement

First 50 hours of maintenance (first 50 hours only)

- Engine oil and oil filter element - replacement

The first 500 hours of maintenance (only in the first 500 hours, and also every 250 hours of maintenance)

- Engine oil and oil filter element - replacement
- Fuel fine filter element - replacement
- Gear oil for walking reducer - replacement
- Air filter main element and safety element - inspection/cleaning

The first 1000 hours of maintenance (only in the first 1000 hours, at the same time every 500 hours of maintenance)

- Hydraulic oil return filter element - replacement
- Air filter main filter element and safety filter element - replacement

Every 8 hours maintenance

For details on the following items, see the Operation/Maintenance section.

- Working device is filled with grease
- Check coolant level in cooling system, add coolant
- Check engine oil level, add oil
- Check fuel level, add fuel
- Check hydraulic oil level, add oil
- Fuel pre-filter - check/drain
- Check electric wiring
- Check and adjust Alternator belt tension

Every 100 hours of maintenance

- Engine oil and oil filter -- check/fill

Maintenance every 250 hours

- Engine oil and oil filter element - replacement
- Grease for slewing bearings and pinion gear - filling
- Radiator and condenser fins - check/clean
- Gear oil level of walking reducer - check
- Fan belt - check/adjust
- Lock core - maintenance/lubrication
- Hinge - maintenance/lubrication

Maintenance every 500 hours

- Fuel fine filter element - replacement
- The guide cartridge - replacement
- Gear oil for walking gear reducer - replacement
- Fuel pre-filter element - replacement
- Maintenance every 250 hours shall be performed simultaneously

Maintenance per 1000 hours

- Hydraulic oil return filter element - replacement
- Gear oil for walking reducer - replacement
- The guide cartridge - replacement
- Air filter main filter element and safety filter element - replacement
- Grease for slewing support gear - inspection
- Maintenance should be performed at the same time every 250 and 500 hours

Every 2000 hours of maintenance

- Change hydraulic oil
- Change hydraulic oil
- Maintenance should be performed at the same time every 250, 500 and 1000 hours

Maintenance every 3,000 hours

- Grease in oil pool of rotary device - replacement
- Coolant - replacement (recommended)
- Maintenance should be performed at the same time every 250, 500 and 1000 hours

Notice: Special tools are required for inspection and maintenance. Please contact mechmaxx dealer.

Maintenance Interval for Hydraulic Breaker

For machine equipped with a hydraulic breaker, the hydraulic oil deteriorates faster than for normal bucket digging operations, so set the maintenance intervals as follows.

- Replace hydraulic filter element

On a new machine, replace the element after the first 100 to 150 hours, then carry out further replacement of the element according to the table on the right.

- Change oil in hydraulic tank

Change the oil according to the table on the right.

X: Breaker operating ratio (%)

Y: Replacement interval (H)

(A): Hydraulic oil return filter, hydraulic tank breathing valve filter, pilot filter filter replacement cycle

(B): Hydraulic oil replacement cycle

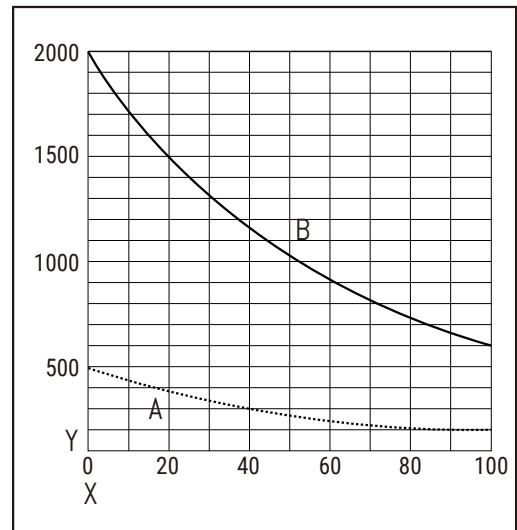

REMARK:

- Breaker operating ratio 100% means that only the breaker is used
- Breaker operating ratio 0% means that the breaker is not used
- The hydraulic mailbox breathing valve filter element needs to be cleaned irregularly in the replacement cycle.

Maintenance procedures

Engine maintenance and maintenance

Engine oil and oil filter element - replacement

WARNING



If the engine is operated without sufficient heating, the working device will become slow in response to the joystick and cannot move as intended by the operator. Therefore, after the engine is started, idle for 5 minutes to warm up the engine. Especially in cold areas, be sure to carry out adequate heating operation.

Sudden engine shutdown will greatly shorten the service life of the engine components. So do not suddenly shut down the engine except in emergencies. The engine should be run at a low idle speed for about 5 minutes to cool the engine gradually.

After the engine stops, parts and oil are still in a high temperature state, which can easily lead to burns. We can't start working until the temperature cools down.

Waste oil and liquid should be disposed of in an environmentally friendly manner

When using CI-4, change the oil every 250 hours or 3 months (50 hours for the first time), whichever comes first. The conditions applicable to the 250-hour interval are:

The oil filter meets the engine specification, as do the original components.

Sulphur content of engine fuel shall not exceed 0.1% by weight.

The oil used meets the requirements

The oil used conforms to "recommended lubricants and accessories".

Select the correct oil viscosity relative to the ambient temperature, see "Correct selection".

Change the oil and oil filter every 100 hours if any of these conditions are not present, or if the machine is operating in an acidic, particularly dusty environment, or using fuel with sulphur content greater than 0.5%.

NOTE

- Pay attention to
- Pan replacement oil volume: 3.7L
- Prepare a strainer wrench.
- During inspection, if the machine is tilted, it should be in a level state before inspection.
- Need to check the oil level every day, too much or too little oil will cause trouble.

1. Place an oil container directly under the plug (P) at the bottom of the machine. Loosen the plug with 0.86 in extension sleeve (P).
2. In order not to let the oil splash on the body, do not remove the plug first, let the oil slowly discharge from the plug (P). At the end of discharge, remove the plug completely to drain all oil from the sump.
3. Check the oil discharge. If you find a lot of metal shavings and foreign matter, please contact the dealer.
4. Install plug (P).

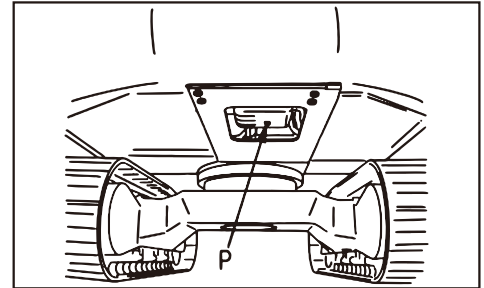
**Fan belt - check/adjust**

The engine must be stopped while checking the fan belt tension, as rotating parts can cause personal injury.

NOTE

Check the fan belt every 250 hours.

CHECK

With about 98N (10kgF) force, press the middle part of the crankshaft pulley and fan pulley, if the deflection is 0.27 ~ 0.35 in, it is qualified.

ADJUST

- lever
 - Prepare wooden blocks.
1. Open the rear hood of the engine and lock it with the brace.
 2. Loosen the adjusting bolts and mounting bolts of the ALTERNATOR.
 3. Adjust the alternator, press the middle part of the crankshaft pulley and fan pulley with a force of about 98N, so that the deflection is 0.27~ 0.35 in.
 4. Tighten the adjusting bolts and mounting bolts of the ALTERNATOR.
 5. Check whether the pulley is damaged, whether the V-groove is worn and whether the V-belt is worn. In particular, check whether the v-belt is in contact with the bottom of the V-groove.
 6. If the belt has been stretched without adjustment margin or there is a cut or crack on the belt, please contact the local dealer for replacement in time.
 7. After adjusting the rear cover, put on the rear engine cover and lock it.
- The surrounding of the hydraulic tank breathing valve needs to be cleaned irregularly during

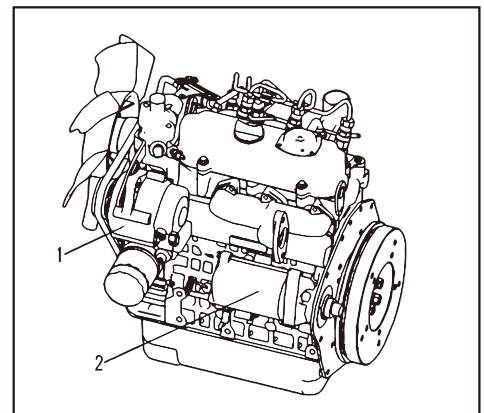

Fuel system maintenance and maintenance

Water and sediment in fuel tank - discharge

NOTE

- Only diesel oil should be used when flushing the inside of the tank.
- For routine maintenance, water and sediment in the fuel tank can be discharged from the bottom of the fuel tank plug.

Fuel pre-filter element - replacement/maintenance

(1) Fuel pre-filter - drainage and cleaning

- After engine shutdown, all parts are still in a high temperature state, so do not replace the filter immediately. The replacement can only be carried out after the temperature of each part comes down.
 - When the engine is running, there is high pressure in the fuel hose. After the engine is stopped, wait for 30 seconds to release the pressure before operation.
 - Do not go near an open flame.
 - Prepare a strainer wrench.
 - Prepare a container for discharging fuel.
1. Open the engine cover, ensure that the brace is locked, and place the valve in the closed position.
 2. Remove the water collecting cup of fuel pre-filter and drain the water clean. If the water collecting cup contains impurities, clean the water collecting cup with clean diesel oil.
 3. After cleaning the water collecting cup, install the water collecting cup by rotating the filter wrench counterclockwise.
 4. Open the valve, loosen the brace and close the engine cover.

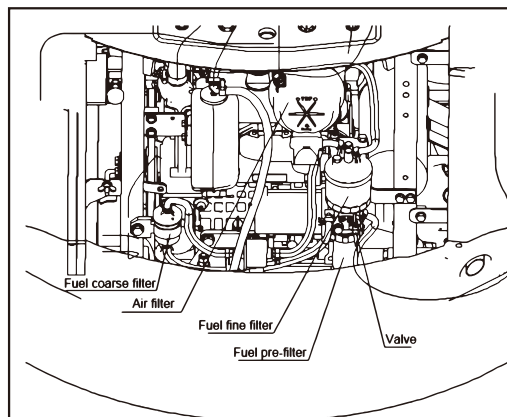

NOTE

- The water in the water cup needs to be drained frequently, and if it is mixed with the fuel, it will cause damage to the engine.
- When impurities accumulate in the cup, clean the cup immediately, otherwise impurities may enter the engine and cause engine clogging or early wear.

(2) Fuel oil fine filter element - replacement

1. Open the rear hood of the engine and lock the rear hood with a brace.
2. Turn the fuel fine filter element to the left with the filter element wrench, and remove the filter element.
3. Clean the filter seat, coat the sealing ring of the new filter element with oil, turn the filter element to the right by hand, until the sealing gasket of the filter element contacts the sealing surface of the mounting seat.
4. Tighten the filter 3/4 to the right with the filter wrench.
5. After the replacement of the fine filter element, open the valve for exhaust. See "Fuel system exhaust" for exhaust method.

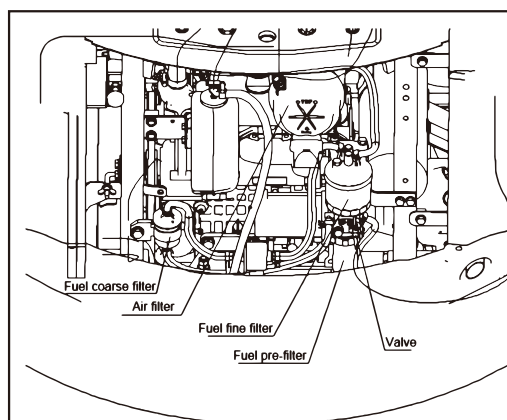

Pay attention to

- It is not allowed to fill the fuel directly into the filter element of the fine filter, otherwise the fuel that does not pass the fine filter will cause nozzle blockage or system failure.
- The filter element must use pure parts of mountain reconstruction machine, otherwise it will lead to foreign body entry or oil injection system failure.

Fuel system - exhaust**WARNING**

- When working with fuel injection equipment, ensure that high-pressure fuel does not come into contact with unprotected parts of your body.
- If the tank runs out of oil or air enters the fuel system for some reason, air must be expelled from the fuel system.

In any case, ensure that the fuel system is completely sealed before starting the engine, otherwise the fuel injection pump can be seriously damaged as a result.

1. Switch the start key to the ON position to power up the electronic fuel pump and start working.
2. Keep the power on for at least 10 minutes to ensure that the oil circuit is full of fuel oil.
3. Start engine and run engine at low idle for approximately 10 minutes with safety locking lever in lock position.
4. Check to confirm no leakage after startup.

NOTE

- The exhaust method is the same when the fuel is exhausted.

Maintenance of cooling system**Radiator and condenser fins - clean****WARNING**

- Compressed air, steam or water may cause personal injury. Wear protective equipment such as protective eye mask. Radiator fins are easy to fall down.
- When using compressed air, keep a proper distance from the radiator fins to prevent damage.
- Blow on the radiator core vertically. If the radiator is damaged, it will cause leakage or overheating.
- Daily inspections are carried out on dusty work sites without limitation of maintenance intervals.

1. Open the rear hood, lock it with a brace, and then open the left door;
2. Use compressed air to remove all sludge, dust and leaves attached to the fins of the water radiator and hydraulic oil radiator, and clean the air filter at the same time.
3. Close the left door and rear hood and lock it.

NOTE

- All fins must be cleaned every 250 hours.
- The air filter on the side door should be cleaned as long as there is debris or too much dust.

Internal cooling system - cleaning/replacement

NOTE

- The coolant is antifreeze and antirust. Check the antifreeze performance of the coolant every 500 hours.
- It is recommended to replace the coolant every 2 years or 3000 hours, in advance according to the use of coolant.
- If the coolant is not replaced in time, the cooling system may be blocked and the engine may be stuck to the cylinder.
- The cooling system needs to be cleaned each time the coolant is changed.
- Do not inject cold coolant into an engine that is running or has just finished but the body temperature is still very high. This may cause cracks in the cylinder block and head.
- Cooling system capacity is approximately 5.05 litres when filling.
- When the plant starts, the cooling system has been filled with a mixture of coolant, water and concentrated antifreeze, which can lower the freezing point of the coolant and increase its boiling point.
- The concentrated coolant contains an effective anti-rust additive to protect the engine and radiator internal waterways, but the additive is of limited duration.
- Do not mix the special coolant for mountain reconstructors with any antifreeze or additives made by other manufacturers. The mixture may have negative effects.
- The content of antifreeze should not be less than 40% in the coolant. The proportion of antifreeze to 40% of the coolant can reduce the freezing point to -13°F. Antifreeze is 50% of the coolant, which can lower the freezing point to -34.6°F.
- When determining the coolant (antifreeze) to water mixing ratio, check the past minimum temperature. In practice, when determining the mixing ratio, set it at a temperature 50°F below the minimum temperature. The replacement cycle.

Air filter maintenance and maintenance

Overview of air filters

The air filter prevents dust and other impurities from entering the engine. The air first passes through the main filter element of the outer filter, and then through the safety filter element. Engine wear depends largely on the cleanliness of the intake air. Therefore, it is very important to check the air filter regularly and maintain it.

Air filter adopts radial seal and double filter form. Air filter structure is as follows:

- A. Differential pressure indicator (optional)
- B. joint
- C. Air filter housing
- D. Safety filter element
- E. the primary filter
- F. Air filter end cover
- G. dust exhausting valve
- H. Check The Times label
- I. lock

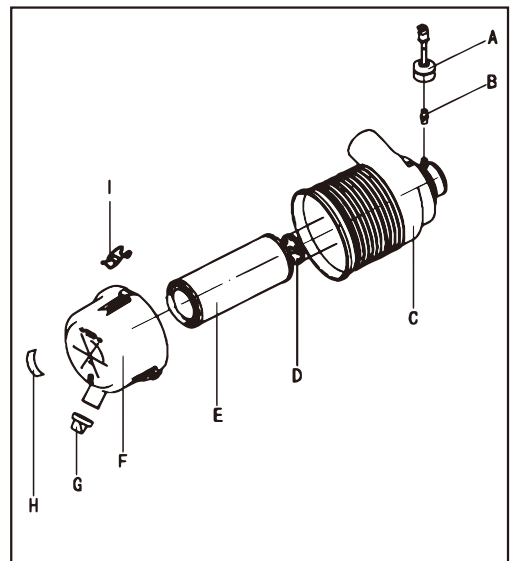

NOTICE

- Under no circumstances should you run an engine without an air filter or if the air filter is damaged.
- Check the pipeline from the air filter to the engine intake manifold periodically for leaks and damage.
- Prepare a spare air filter and store it in a dry and dust-proof place.
- If the engine is inspected, cleaned or replaced while it is running, dust will enter the engine and cause engine damage. Before performing these operations, shut off the engine.
- There is a danger of dirt flying out and causing injury when compressed air is used. Wear protective glasses, dust mask or other protective devices.

Air filter. - Check

Open the engine rear hood to check whether the air filter alarm displays alarm

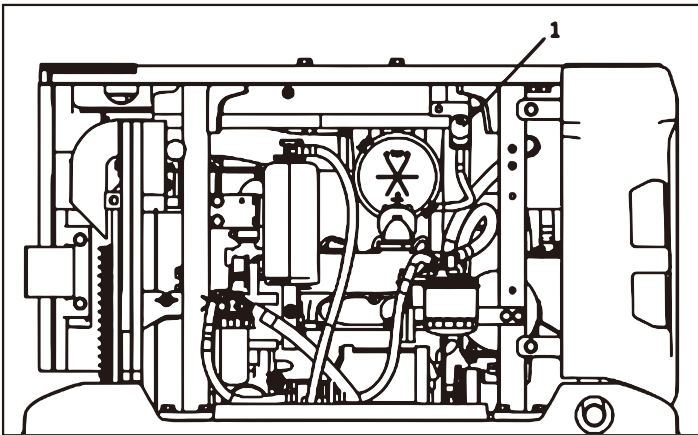
**IMPORTANT**

- If the air filter element is frequently cleaned before the alarm, the performance of the air filter can not be fully played, making its filtering effect worse.
- In addition, dirt attached to the filter element during cleaning will frequently fall to the inner filter side, suction engine, resulting in engine wear

Air cleaner - Clean up

1. Open the engine cover and ensure that the brace is locked.
2. Open the three locks on the end cover of the air filter (I).
3. Remove the end cover of the air filter (F).
4. Empty and clean the end cover and dust exhaust valve (G), and clean the inside of the end cover shell with a clean cloth.
5. Remove the main filter element (E).

NOTICE

- If the dust valve (G) is cracked, damaged or lost, the dust valve needs to be replaced. If the dust valve is intact, the dust valve needs to be cleaned.
- Main filter element (E) adopts radial seal, there will be a certain resistance when taking off, should be pulled out while rotating the main filter element, remember not to beat the shell and the main filter element.
- Do not remove the safety filter element (D), otherwise, dirt is easy to enter and cause engine failure. Unless the safety filter element is damaged and spare parts are ready for replacement.

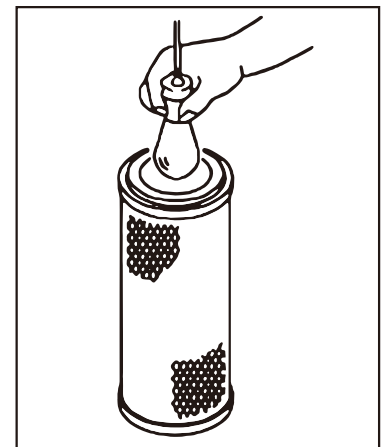

6. Check and clean the main filter element (E) and shell (C).

- Mechanical cleaning: the main filter element on a soft, clean object surface carefully beat the end of the filter element, do not rely on a hard object violently hit or hit the filter element.
- Compressed air cleaning: dry compressed air (less than 0.69mpa {7kg/cm²}) from the inside of the filter along the fold to blow outward, and then from the outside of the filter along the fold to blow inward, and again from the inside to blow outward, nozzle and filter surface distance is not less than 0.1 ~ 0.2 in.
- The outer filter element needs to be replaced after 6 times of cleaning or after 1000h. The safety filter element should be replaced when the external filter element is replaced.
- Even if the cleaning times of the outer filter element did not reach 6 times, the alarm still alarms when the filter element is blocked after cleaning, and the inner filter element and the safety filter element need to be replaced.

7. After cleaning the filter element, use light to illuminate the inside of the filter element or reverse sunlight to check. If there are holes or thin parts on the filter element, replace them.

NOTICE

- Must not be knocked to clean the main filter element;
- The life of the filter element can not be judged only by eye observation, the pressure differential indicator is the most reliable;
- Air filter end cover (F) can not be opened for too long, if there is no suitable filter element to replace immediately, should immediately cover the end cover;
- Pure air filter element for mountain reconstruction machine must be used.

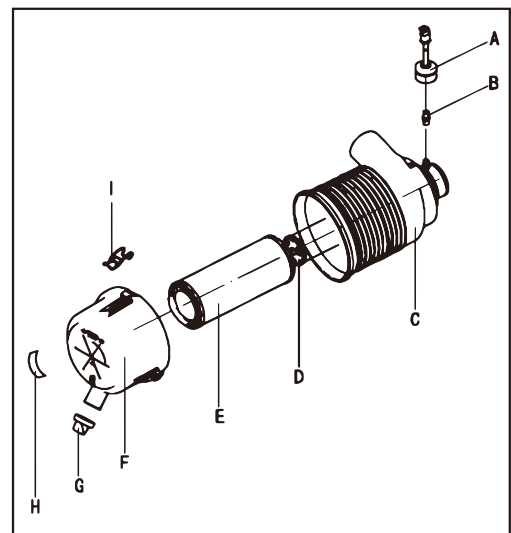

8. Push the edge of the main filter element (E) by hand, carefully install the main filter element, and confirm that the main filter element is fully loaded into the shell.

9. Make the TOP arrow of the end cover (F) face up and install it on the shell of the air filter, and fix it with the lock (I).

Pay attention to

- Can not use the force of the end cover to push the main filter element, which will damage the housing and the lock.
- If the end cover cannot be installed in place because of the main filter element, remove the end cover and continue to push the main filter element until the main filter element is installed in place.
- The dust valve on the end cover should be kept facing down for dust removal.
- For each cleaning of the main filter, one label on the check times label (H) at the end cover of the empty filter should be torn off. The label can be cleaned up to 6 times, and then it must be replaced.

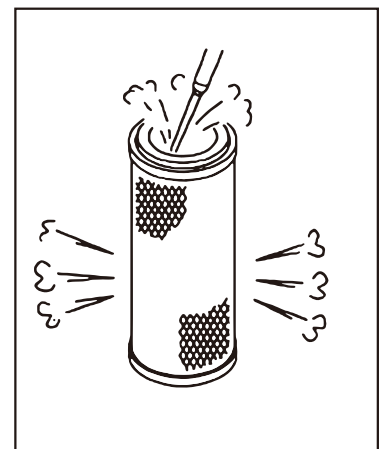

Air filter element - replacement

1. Open the engine cover and ensure that the brace is locked.
2. Open the lock on the end cover of the air filter (I).
3. Remove the end cover of the air filter (F).
4. Empty and clean the end cover and dust exhaust valve (G), and clean the inside of the end cover shell (F) with a clean cloth.
5. Remove the main filter element (E).

Pay attention to

- Do not remove the safety filter element at this time
 - If the dust valve (G) is cracked, damaged or lost, the dust valve needs to be replaced. If the dust valve is intact, the dust valve needs to be cleaned.
 - Main filter element (E) adopts radial seal, there will be a certain resistance when taking off, should be pulled out while rotating the main filter element, remember not to beat the shell and the main filter element.
6. Clean the inside of the air filter shell (C) with a clean cloth.
 7. Prepare the new main filter element and safety filter element, and check whether the new filter element is damaged, if there is damage, replace it immediately.
 8. Remove the safety filter element (D) and quickly install the new safety filter element.
 9. Push the edge of the main filter element (E) by hand, carefully install the main filter element, and confirm that the main filter element is fully loaded into the shell.
 10. Make the TOP arrow of the end cover (F) face up and install it on the shell of the air filter, and fix it with the lock (I).

NOTE

Safety filter efficiency is generally much lower than the main filter, the filter area is much smaller, maintenance work, can prevent impurities into the engine.

When the main filter is damaged, the safety filter will protect the engine.

If the main filter element has been cleaned or replaced, but the differential pressure indicator alarm, it indicates that the safety filter element is blocked.

NOTICE

Safety filter element can only be replaced, not cleaned.

Safety filter element is generally replaced at the same time when the main filter element is replaced.

Do not remove the safety filter element unless it needs to be replaced.

Remove the safety filter element should be very careful, and the removal action should be accurate in place, so that impurities are not easy to enter the engine.

After replacing the safety filter element, carefully check to ensure that the new safety filter element is installed correctly.

Operation instructions for electric welding

- The battery switch must be turned off before welding the machine or any device installed on the machine.
- Disconnect the battery cable and unplug the cable plug from the electronic controls before any welding is performed on the machine.
- Turn off the battery switch when disconnecting and reconnecting.
- The grounding wire of welding equipment should be as close to the welding point as possible.
- Remove all paint within a radius of at least 10 cm (4 inches) around the weld before welding. Because heated paint gives off harmful gases.
- All paints break down when heated and form large amounts of compounds that can cause pain, irritation and health hazards if exposed to them for long periods of time.
- In addition to health hazards, welding quality and strength will be damaged, and even lead to future weld fracture. Therefore, do not directly on the paint surface welding.

Maintenance of Hydraulic System

Hydraulic Oil Return Oil Filter Element - Replacement

WARNING



- After the engine is stopped, the parts are still in the high temperature state, so do not immediately replace the oil filter element. The parts cannot be replaced until the temperature drops.

Notice

- If the machine is equipped with a hydraulic crushing hammer, the hydraulic oil will deteriorate faster than normal bucket work. See the item "maintenance cycle when using hydraulic crushing hammer" for the replacement cycle.
- The filter element of the return oil filter should be replaced every 1000 hours after the first use and every 1,000 hours after that.

1. Remove the upper flange (1) connecting pipe.
2. Remove the upper flange (1) mounting bolt (piece 2 is the filling port plug cap)
3. Take out the upper flange (1) and return filter (3).
4. Unscrew the old oil return filter element (3), and then replace the new oil return filter element (3).
5. except the filter element (3) clean the removed parts with clean oil.
6. Restore the pipe connected to the flange.

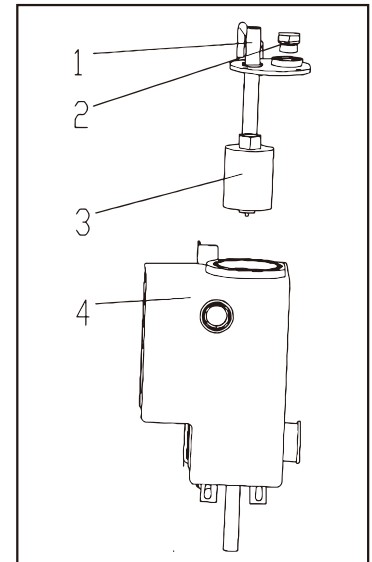

Hydraulic tank oil filter element - check/clean/replace

WARNING



- After the engine is stopped, all parts are still in the high temperature state, so do not immediately clean the oil absorption filter. The parts cannot be replaced until the temperature drops.
- Oil may spout when the cap of the suction port is removed. Press the top button of the breather valve to release pressure inside the tank before removing the cap.

Notice

Check and clean the oil filter element of the hydraulic oil tank after the first use of 50 hours and 500 hours, and then check and clean it every 500 hours. Replace every 2000 hours. This maintenance time is halved when using the crushing hammer. ◦

1. connect the upper method component(1) and remove the connecting bolt.
2. Remove the upper method component (1)
3. Unscrew the oil absorption filter element from the tank(2)

4. Check whether there are metal particles and other impurities on the oil absorption filter element. If there are, please immediately contact mechmaxx dealer for diagnosis and maintenance. If not, clean the removed filter element and other parts with clean diesel oil

5. Clean the oil absorption filter element or the new oil absorption filter element into the oil tank (2) inner filter seat

Install upper flange(1) seat

6. Install upper flange (1) components and pipes.

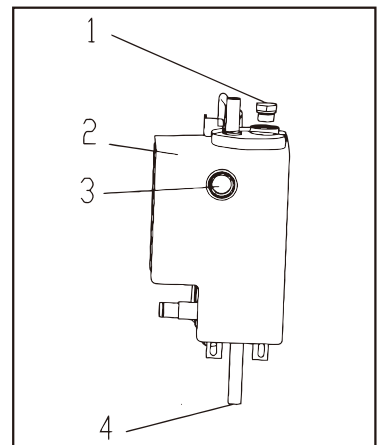
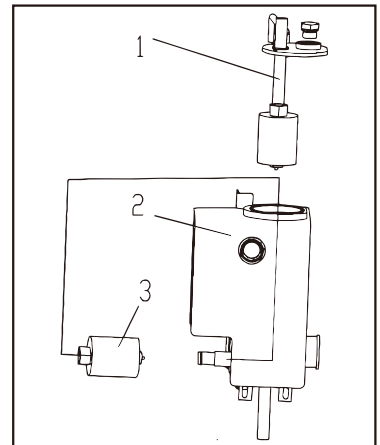
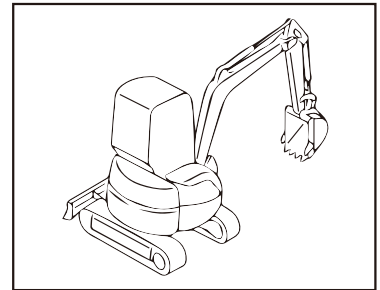

Hydraulic Oil Replace

WARNING



- After the engine is stopped, all parts and hydraulic oil are still at high temperature, so do not immediately replace the hydraulic oil and filter element, or it will cause burns. To wait for the parts and hydraulic oil temperature down after the start of maintenance. ◦
- Oil may spout when the cap of the suction port is removed. Press the top button of the breather valve to release pressure inside the tank before removing the cap.
- Oil receptacles shall have a capacity of at least 110L.
- Fuel capacity: about 110L.
- Prepare sleeve with extension rod, 13mm square or 24mm. ◦

1. Rotary machine makes the oil discharge screw plug under the hydraulic oil tank located in the middle of the left and right tracks.
2. Retrieve the oil cylinder of the bucket rod and bucket, lower the moving arm and dig the bucket tooth into the ground. And lower the bulldozer to the ground.
3. After flame out, turn the electric lock to the ON position and put the safety lock lever in the position. Shake the control handle left and right to release the pressure inside the system. After completion, turn the electric lock to the OFF position and put the safety lock lever in the locked position.
4. Place the oil receiving container under the drain screw plug(4) under the oil tank. remove the lower drain screw(4) to drain oil .and loosen the upper fill screw plug(1).
5. Remove the upper flange cover after bucket. charging the oil .clean the top flange cover and the bottom of the tank remaining impurities and other contaminants
6. Install the upper production cap and drain screw plug (4) and screw it .check the D shape diagram installed on the cap and screw plug. if damaged, please replace the O shape diagram.
7. At this time ,it is necessary to carry out maintenance at the same time to clean or replace the oil absorption filter element and oil return filter element. the replacement method is described in the previous three pages
8. After the replacement ,add hydraulic oil to the specified amount of replacement oil through the filling screw plug to check whether the oil level is in the middle of the middle of oil level gauge .
9. Install the filling screw plug(1) and tighten it.
10. After the replacement of hydraulic oil, put each connecting rod in the middle position make the engine idle for 2-3 minutes, exhaust each action, replenish the hydraulic oil to the middle position of the oil level meter and then start the operation.

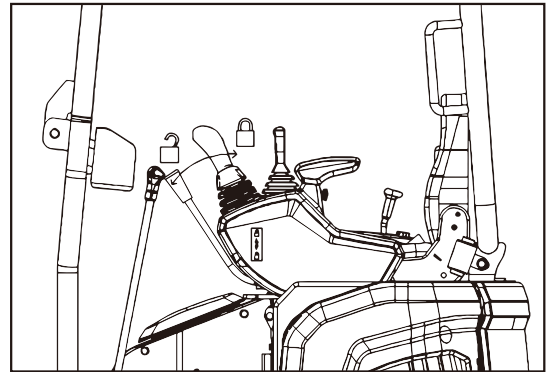
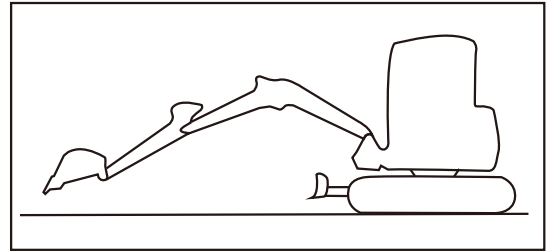

Gear Oil in Running Motors and Reducers - Inspection/Refueling

WARNING



- When the engine stops, the parts and gear oil are still in a high temperature state, which is easy to cause burns. Wait for the temperature to cool before starting the operation. .
- If pressure remains in the gearbox, oil or studs may fly out. Slowly loosen the plug to release internal pressure.
- Prepare socket wrench.
- Replace the gear oil in the walking reducer after 500 hours of first use, and replace the gear oil in the walking reducer after 250 hours of first use. During normal operation, check and add gear oil every 250 hours, and replace gear oil in the walking reducer every 1000 hours.

1. Position the motor in the shown position
2. Use an inner hexagon wrench to remove the stud plug of the oil opening and check whether the internal gear oil is under the gear oil opening and check whether the internal gear oil surface of the oil opening through the stud plug hole
3. If the oil level is too low, it is necessary to fill the same specification of gear oil from the oil filling port.
4. When filling the gear oil flows out of the oil filling hole, tighten the screw plug and clean the oil pollution at the reducer shell with a clean cloth

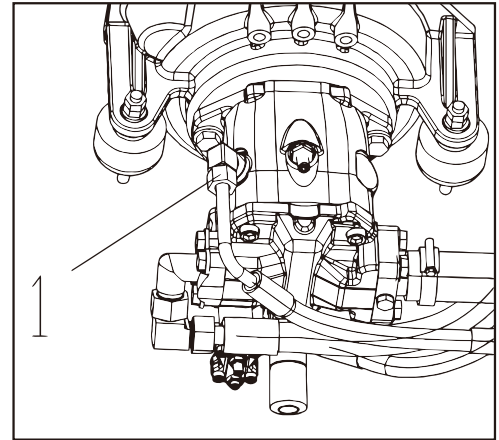

Hydraulic System - Exhaust

Notice

If the pump housing is not filled with hydraulic oil when the pump operation, will cause abnormal high temperature pump, pump may be prematurely damaged. Therefore, exhaust must be carried out.

1. Discharge air from the main pump

- 1) Open the rear cover and remove the hose and connector at (1) of the main pump.
- 2) Slowly fill the oil port with clean hydraulic oil. When it is seen that the liquid level of the oil port is almost full and there are large bubbles, the filling is suspended.
- 3) After the liquid level at the oil port stops bubbling, the liquid level will decline. At this time, slow refueling is conducted again until the liquid level is almost full and stable and no longer drops.
- 4) Check whether the seal ring of the joint hose is damaged, and replace the seal ring if it is damaged. Tighten the adapter hose. Clean up any spilled oil.

2. Refer to "starting engine" in the operation section, starting engine. Start the engine at a low idle speed for 10 minutes before proceeding to the next operation.

3. Drain the air in the oil cylinder

Notice

If the engine is initially run at high speed and the cylinder is operated to the end of the stroke, damage to the plunger seal will result from air entering the cylinder.

- 1) Run the engine at low idle speed, and extend and withdraw each cylinder for 4 to 5 times. Be careful not to operate the cylinder to the end of the stroke (stop at 4 in from the end of the stroke).
- 2) Then, operate each cylinder to the end of its stroke for 3-4 times.
- 3) Finally, operate each cylinder to the end of its stroke 4-5 times to completely exhaust air.
- 4) Exhaust air from accessories (when equipped with accessories)

If a crusher or other accessory is installed, run the engine at a low idle speed and repeatedly operate the accessory pedal (about 10 times) until air is expelled from the accessory oil path.

Notice

- If the manufacturer has specified the method of exhaust from the annex, exhaust in accordance with the specified method.
- After the exhaust operation is completed, shut down the engine and wait 5 minutes before starting again to eliminate the oil bubbles in the hydraulic cylinder.
- Check for leaks and wipe up any spilled oil.

5. After the above exhaust is completed, check the oil level of the oil gauge of the hydraulic oil tank. If it is insufficient, add the hydraulic oil to the specified oil level.

Crawler tension- inspect/adjustment Machine with metal treads

Wear of the pins and bushings of the lower body varies with operating conditions and soil types. Therefore, in order to maintain the standard tension, to each 250 Check the tension of the track for hours.

For inspection and maintenance, park the machine in a firm, flat place.

CHECK

1. Run the engine at low idle speed and slowly move the machine forward for a distance equivalent to the length of contact between the track and the ground, then stop the machine.
2. Check whether the track board is broken or damaged.

Track Tension-Adjustment

WARNING



Be sure to loosen the plug. 1 More than one lap. If the screw plug 1 Loosened more than a circle, under the high pressure of grease, there is a risk of flying out. At this point, do not loosen the screw removal plug 1 Do not face the plug for any part other than the plug 1 The installation direction of the. If the method provided here does not loosen the track tension, contact the dealer and commission the repair.

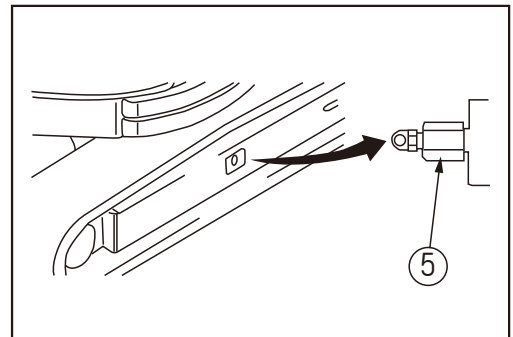

Replace Bucket Teeth

Replace the teeth before the wear reaches the adapter.

WARNING



• It is dangerous if the work equipment is mistakenly moved when replacing the teeth. Set the work equipment in a stable condition, stop the engine, then set lock lever securely to the LOCK position.

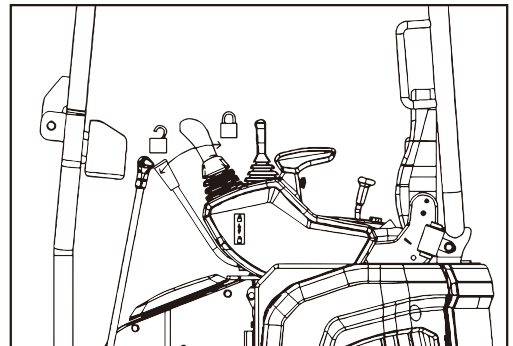

Working Device Grease - filling Notice

The grease filling point of the working device lubricates every 8 hours (every day).

If there is abnormal noise in the parts that need lubrication, the lubrication should be carried out regardless of whether there is time for maintenance.

When excavating in water (on civil land, etc.), lubricate the pin shaft immersed in water.

1. Lubricate according to the lubrication position in the right picture. Lower the actuator to the ground and shut off the engine.
 2. Grease pump is used to inject grease through the grease nozzle shown by the arrow.
 3. After lubrication, wipe off the old squeezed grease
- (1) Bucket and connecting rod connecting pin (1 place)
 - (2) Bucket bar and bucket connecting pin (1 place)
 - (3) Bucket bar and rocker arm connecting pin (1 place)
 - (4) Both end of bucket cylinder (2 place)
 - (5) Bulldozing shovel shovel cylinder at both ends (2 place)

- (6) Push shovel root pin (2 place)
- (7) Both ends of boom cylinder (2 places)
- (8) Both ends of cylinder bucket rod (2 place)
- (9) Bucket rod cylinder piston rod end (1 place)
- (10) Boom root pin (1 place)
- (11) The swing frame is connected with the platform shaft (2 place)
- (12) Yaw both ends of cylinder (2 place)

Maintenance and Lubrication of Lock Core

WARNING



- After the door lock is used for a period of time, there will be dust and impurities in the lock core, which will cause the lock core to become stuck and fail to open. Do not force it to open, otherwise the lock core will be damaged.
- Fill the lubricant every 250 hours.

When the key is inserted halfway, the lock core dust cover is opened. At this time, the carburetor cleaning agent is sprayed into the lock cylinder. The key is fully inserted into the lock cylinder for several rotations, half of the key is pulled out, and the cleaning agent is sprayed again. It can effectively remove internal impurities.

After cleaning, add a small amount of diluted lubricant.

In addition, pre-tighten the hood lock shaft and apply a small amount of lubricant to the lock shaft and lock contact.

Maintenance and Lubrication of Hinge

WARNING



- After the hinge is used for a period of time, dust, impurities, etc. may cause the hinge to be stuck and the door/cover to be closed. Do not forcibly open the door/cover at this time, otherwise the door/cover will be damaged.
- Add lubricant once every 250 hours.

Clean dust and impurities from the door/cover and apply a little lubricant to the hinge.

Slewing and Pinion Grease - Check/Refill

WARNING



- Do not turn the slewing bearings and slewing pinions while lubricating them.

Filling of Grease

Lubricate the slewing bearing and pinion grease every 250 hours. Do not lubricate frequently.

1. Lubricate through the yellow nozzle shown by the arrow (right side of the car).
 - (1) slewing support (1 place)
 - (2) rotary gear (1 place)
2. After lubrication, wipe off the old squeezed grease.

When lubricating the slewing bearings and slewing gears, the machine may be rotated slightly to change its position.

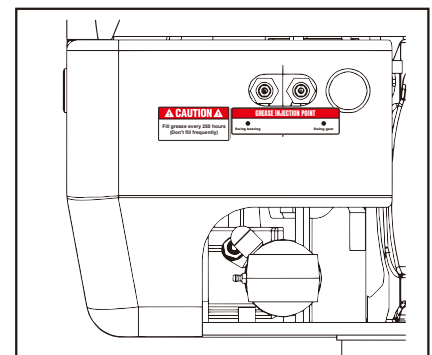

VIBRATORY COMPACTOR QUALITY WARRANTY CERTIFICATE

Operator Instructions

Before using the vibratory compactor, the operator must carefully read the operation manual in detail and strictly follow its instructions. Inexperienced operators must undergo formal and systematic training before operating the machine. If the compactor is damaged due to failure to read the manual or lack of proper training, the manufacturer will not be held responsible.

Eccentric Assembly Maintenance and Usage

- The eccentric assembly must be serviced regularly; its normal warranty period is 3 months.
- During operation, gear oil must be replaced in time (recommended every 3 months) to prevent damage or wear caused by foreign particles, which may lead to cylinder and piston damage. The manufacturer assumes no responsibility for such damages.
- Prolonged improper compaction may cause floor deformation or damage to the damping block; the manufacturer will not be responsible.

Pipeline

Use dedicated pipelines designed for the vibratory compactor. During disassembly, ensure the pipes and joints remain clean. If contamination is introduced during disassembly, causing motor scoring or oil leakage, the manufacturer will not be responsible.

Hydraulic Oil Usage

Before installing the vibratory compactor, the hydraulic oil must be filtered, and the oil tank cleaned. The excavator's oil must be replaced regularly according to its service schedule. Damage to the motor caused by untimely oil replacement is not covered by warranty.

Bolts and Nuts Usage & Maintenance

After the first hour of operation, the operator must carefully check whether all bolts and nuts are loose. Afterwards, check every 10 hours. Tighten if necessary. Regular inspection of bolts and nuts should be part of routine maintenance. Re-tighten as required during assembly.

Operating Method

- To maximize efficiency, apply appropriate pressure—neither too high nor too low. Stop operation immediately if cracks or fractures appear to avoid harmful "idle striking."
- Do not use the compactor to support the excavator for long periods.
- Do not work at the same point for more than 30 seconds.
- Do not operate underwater or drop the compactor intentionally.

Special Notes

- Do not connect the main inlet and return ports incorrectly; damage caused by incorrect connection is not covered by warranty.
- Do not operate under excessively high pressure; damage or leakage caused by excessive pressure or back pressure is excluded from warranty.
- It is recommended to connect the return line directly to the oil tank to prevent unstable back pressure that may damage the motor.

Disclaimer:

1. The manufacturer is only responsible for quality-related issues of the compactor itself, not for related losses such as downtime or work injuries.
 2. Damage to excavator parts caused by excessive pressure adjustment or vibration is not covered.
 3. No personnel may be within a 10-meter radius during operation; any losses resulting from violation will not be covered.
- The manufacturer reserves the right of final interpretation.

Warranty Scope

Part Name	Warranty Period	Warranty Coverage
Hydraulic Motor	6 months	Housing cracks, output shaft breakage: free replacement within 1 month; oil leakage after 3 months not covered; user must purchase seals. (High-pressure return must go to oil tank, otherwise cracks are not covered.)
Housing Assembly	6 months	Damage caused by improper operation or unauthorized reinforcement is not covered; steel plate cracks within 3 months: cracked part replaced; welding cracks: customer may weld; if unable, manufacturer provides free welding (other costs not covered).
Eccentric Assembly	6 months	Damage caused by poor gear oil maintenance or excessive idle striking not covered.
Bearing	3 months	Accelerated wear due to lack of lubrication is not covered.
Check Valve	3 months	Damage caused by foreign matter, overdue seal replacement, poor maintenance, user errors, or external impact is not covered. Sticking after one month not covered.
Pipeline Assembly	3 months	Damage caused by poor maintenance, external impact, or over-adjustment of the relief valve is not covered.
Damping Block	No warranty	Highly dependent on operator usage; no warranty or maintenance provided.

Screws, nuts, couplings, and joints are not covered by warranty. Loss, breakage, or deformation caused by failure to tighten nuts, collisions, or fractures are excluded.

Special Notes for Hydraulic Vibratory Compactor Use

1. Operate vertically with the compaction plate level; ensure even force on all sides. Do not operate at an angle to avoid cracking the damping block.
2. Damping blocks are consumable parts and not covered by warranty.
3. Recommended operating pressure: 180–200 Kg/cm². Excessive pressure may damage the motor.
4. Damage caused by excessive pressure is not covered.
5. The main return oil line must go directly to the tank. When the motor stops, the eccentric assembly produces a momentary pulse due to inertia. Poor return flow can easily damage the motor. Note: For compactors above 15 tons, do not connect the pilot return line. If the main return line does not return to the tank (or is overloaded), motor leakage or cracking is not covered.
6. The working surface must not contain protruding hard objects; damage to the bottom plate caused by localized stress is not covered.

SPECIFICATION

WARNING



Please read and make sure that you understand the SAFETY section before reading this section.

Specifications

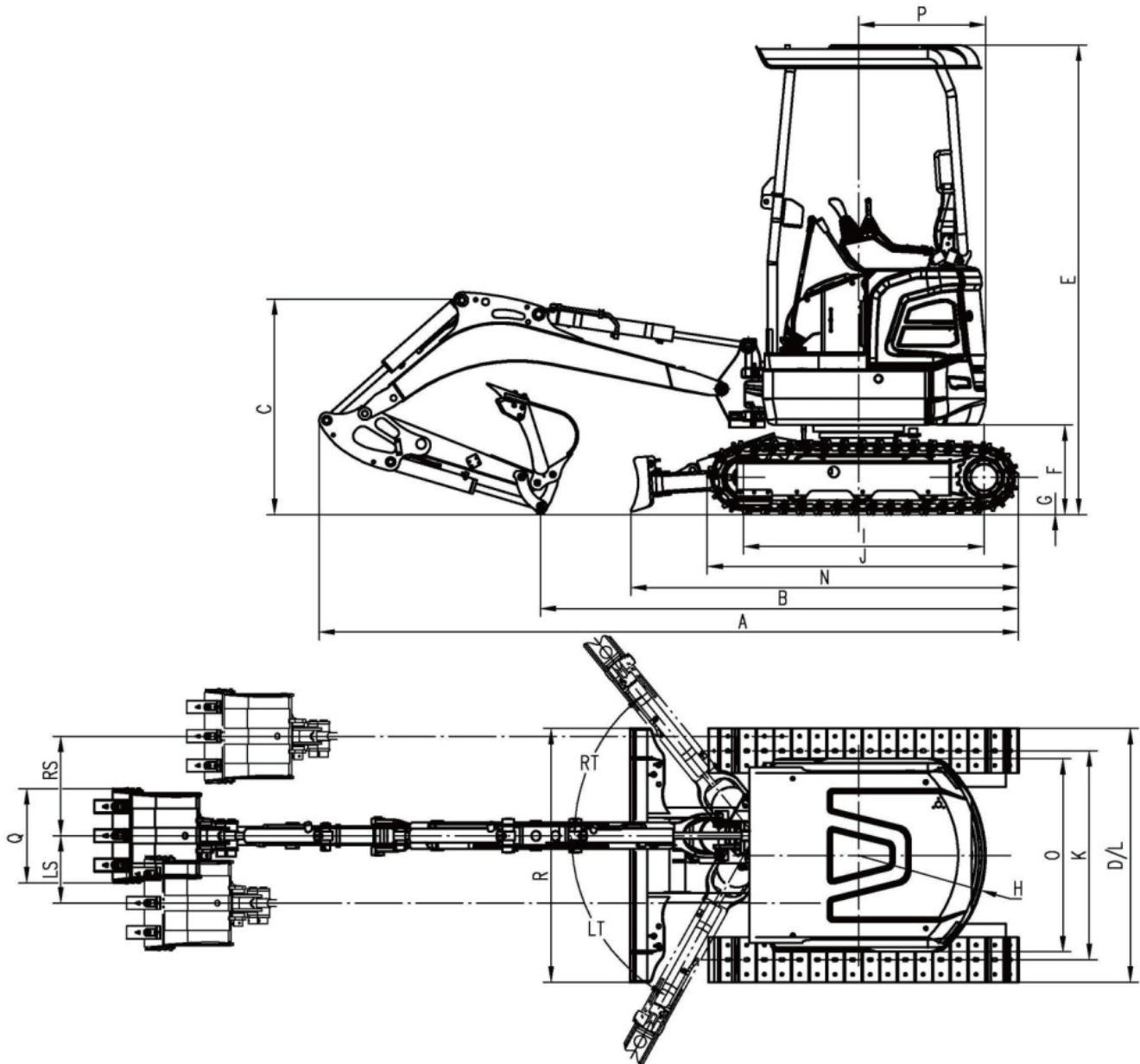

Specifications

	Item (MEC17)	Unit	Parameter
A	Overall length	in	140
B	Grounding length (Transportation)	in	96
C	Overall height(to the top of boom)	in	43.5
D	Overall width	in	38.9/51.5
E	Overall height(to the top of cab)	in	94.6
F	Counterweight ground clearance	in	18.1
G	Min. Ground clearance	in	5.7
H	Tail radius of turning	in	25.5
I	Tumbler center distance	in	48.4
J	Length of track	in	62.7
K	Gauge	in	30/42
L	Track width	in	38.9/51.1
M	Track shoe width	in	9
O	Turntable width	in	78.7
P	Radius of upper structure	in	39
Q	Total width of bucket	in	19
R	Bulldozing shovel width	in	38.9/51.1
RS	Right arm offset	in	20
LS	Left arm offset	in	13.5
RT	Right offset angle of boom	°	51
LT	Left offset angle of boom	°	61
	Ear /Outside noise	dB	80/93±2.5
	Hand-arm system	m/s ²	2.5±0.1
	Whole body vibration	m/s ²	0.5±0.1
	Standard bucket	m ³	0.04
	Travel speed	km/h	2.2/4.3
	Engine type		Kubota-D902
	Engine power	kW	11.8@2300/min
	Operating mass	lbs	3968
	Main valve	L/min	64.4
	Hydraulic pump	Mpa	23
	Swing motor & Reduction gear	r/min	9.5
	Climbing ability	°	30

Working Ranges

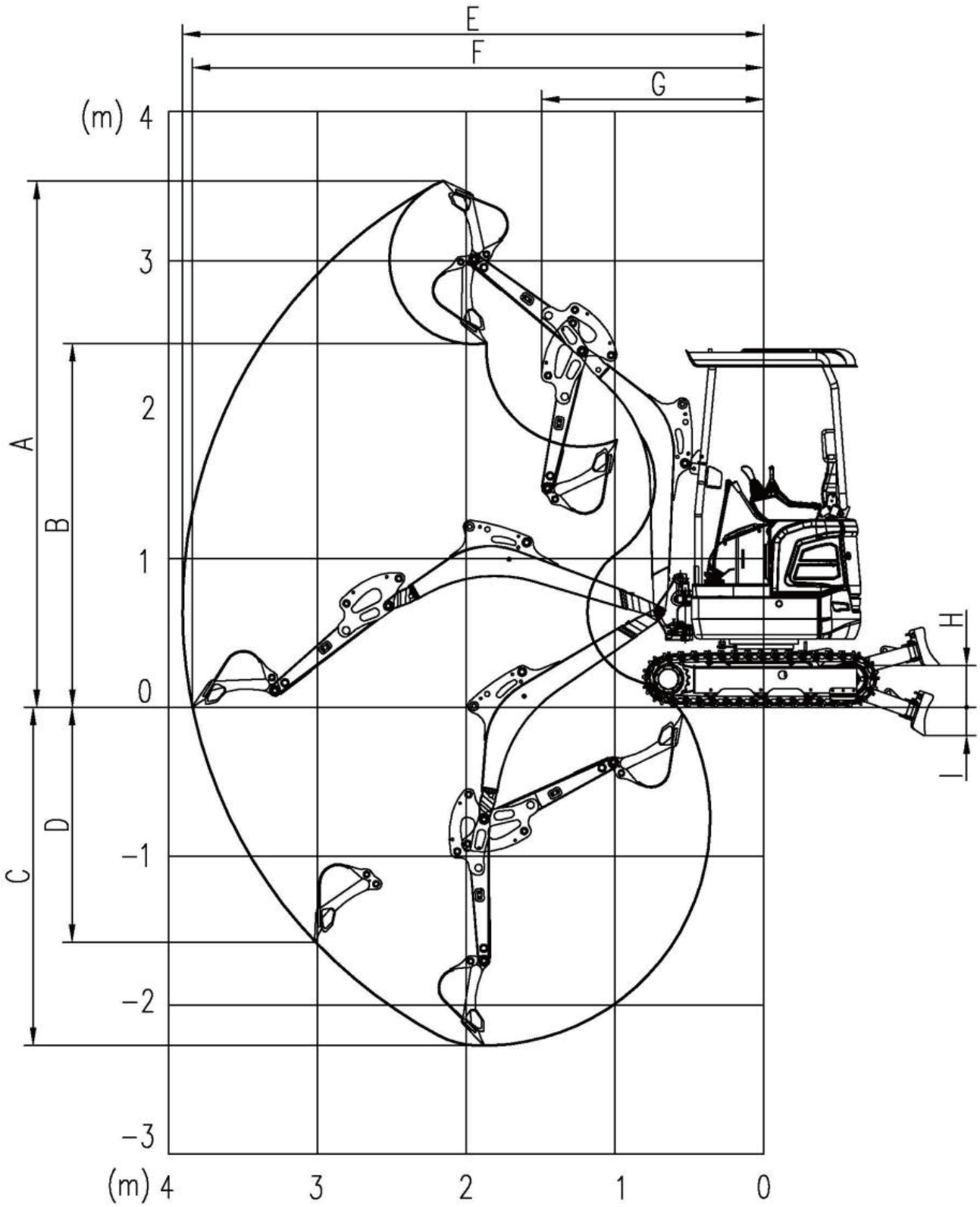

	Item	Unit	Parameter
A	Max. Digging height	in	139.1
B	Max. Dumping height	in	96.2
C	Max. Digging depth	in	89.3
D	Max. Vertical Digging depth	in	75.1
E	Max. Digging reach	in	153.9
F	Max. Digging reached at ground level	in	151.3
G	Min. Swing radius of work equipment	in	58.8
H	Max lifting height of the blade	in	11
I	Max cutting depth of the blade	in	7.4

Lifting Capacity Form

LIFTING CAPACITY FORM

Lift Capacity A in B in	RATED LIFT CAPACITY OVER BLADE, BLADE DOWN -kg			RATED LIFT CAPACITY OVER BLADE, BLADE UP -kg			RATED LIFT CAPACITY OVER SIDE, BLADE UP -kg		
	78.7	118	At Max. Radius @(mm)	78.7	118	At Max. Radius @(mm)	78.7	118	At Max. Radius @(mm)
984			323*@(2577)			323*@(2577)			312@(2577)
78.7			338*@(2965)			205@(2965)			198@(2965)
39.3	554*	422*	366*@(3316)	338	155	131@(3316)	333	147	124@(3316)
0	641*	404*	356*@(3261)	305	145	115@(3261)	300	137	109@(3261)
-39.3	438*		304*@(2767)	279		144@(2767)	272		138@(2767)

NOTICE:

- Please refer to the Operator's Manual for other details.
- According to ISO10567, the rated load is 75% of the effective static tipping load, or 87% (*) of the rated hydraulic lifting load (the standard value is the smaller one). It's able to turn 360 degrees and work on the flat ground.
- Lift capacity stays with ±5% for all available track shoes.

The lifting capacity is based on the criteria of the machine being level on a firm supporting ground. When the machine is operated in conditions that deviate from these criteria (e.g. on soft or uneven ground, on a slope or when subject to slide loads), these conditions shall be taken into account by the operator and need contract manufacture for safety operation.

Standard Configuration and Digging Force

Arm Length MEC17/MEC17PRO	in	37.4 / 45.2
Boom Length	in	71.9
Bucket capacity	m ³	0.04
Arm digging force	kN	9.5
Bucket digging force	kN	16

Operating Weight and Ground Specific Pressure

Track shoes width	in	9
Operating weight	lbs	3968
Ground pressure	kPa	29

Disclaimer

This manual is used as the machine maintenance data, the recorded information including text, data, pictures or other items may be inconsistent with the actual products sold, this manual cannot be used as the basis of product style, the purchase of products shall be subject to the actual delivery. Products are subject to change without prior notice.

ATTACHMENTS AND OPTIONS

WARNING



Please read and make sure that you understand the SAFETY section before reading this section.

Safety First

When installing attachments or options to the machine, it is necessary to pay attention to safety. Please obey the following precautions strictly when selecting, installing, or using attachments or options.

WARNING



General considerations

- Accessories are powerful tools. To prevent serious injury or damage, use them correctly.
- Read through the attached instructions. Do not use attachments without fully understanding the instructions. If the instruction manual is lost, contact the manufacturer or attachment sales company for a new one.
- Install the necessary front cover on the machine as attached.
- Depending on the attachment, vibration noise will make it difficult for colleagues to communicate instructions. Before starting operation, assign a conductor and determine the signal to be used.
- Do not perform rotary operation with heavy loads on the attachment. Doing so on slopes is particularly dangerous.
- A machine with a crusher hammer has a heavier load on the front part of the work unit and is unstable compared to the one with a bucket. To avoid the risk of tipping, do not operate when the attachment is turned sideways.
- When accessories are installed, the range and center of rotation of the machine are different. The machine will move unexpectedly. Be sure to know the machine properly.
- Set up some security lines around the machine before operation to prevent people from entering. Do not operate the machine when there is a man near it.
- To prevent serious accidents caused by misoperation, do not put your foot on the pedal except when operating the pedal.

Precautions when removing or installing

When removing or installing the attachment or option, obey the following precautions, and take care to ensure safety during the operation.

- Carry out the removal and installation operation on a flat, firm ground surface.
- When the operation is carried out by two or more workers, choose the leader and follow his instructions.
- Use a crane when handling heavy objects (more than 25 kg (55 lb)). (The crane must be operated by a qualified operator.)
- Never go under a load raised by the crane.
- Do not carry out operations with the load kept raised by the crane. Always use a stand to prevent the load from falling.
- When removing a heavy part, consider the balance after it is removed. To prevent the machine from tipping over, set a support in position if necessary before removing the part.
- Before installing or after removing the attachment or option, set it in a stable condition to prevent it from falling over.

Attachment Installation

WARNING



When long or heavy work equipment is installed, remember the following precautions.

- Before starting operations, move the machine to a safe place and carry out a test operation to make sure that you fully understand the movement, center of gravity, and working range of the machine.
- Do not swing the work equipment if the machine is at an angle. If the work equipment is swung with the machine at an angle, there is danger that the machine will tip over.
- Always maintain a safe distance from obstacles in the surrounding area when operating. If long work equipment is installed, the working range becomes larger.
- The swing overrun (the distance the work equipment moves before completely stopping after the swing brake is applied) will be greater. There is danger of hitting objects if the swing overrun is miscalculated, so allow extra space to the swing position when swinging.
- The hydraulic drift of the work equipment (the amount of the work equipment moves down under its own weight when it is stopped in a raised position) also becomes greater. Do not stop the work equipment in a raised position; always lower it to the ground.
- Do not swing, lower, or stop the work equipment suddenly. There is danger that the machine may tip over.
- Do not suddenly extend or retract the boom cylinder. The shock may cause the machine to tip over.

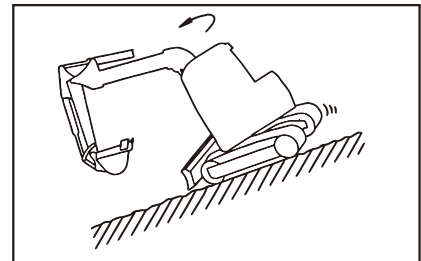
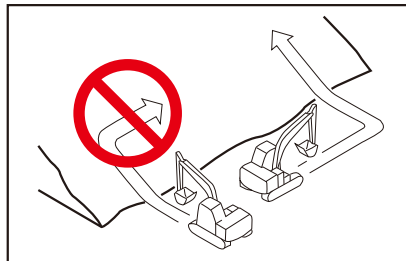
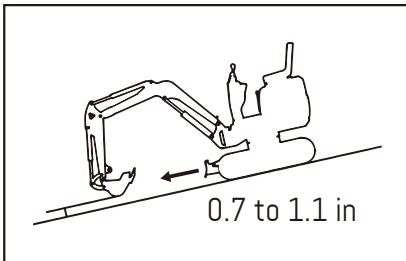

Recommended Attachment Operations

Notice

Select the optimum model of attachment for a hydraulic excavator on which it is to be mounted. Depending on machine models of hydraulic excavator, the kind of attachments or the model of specific attachments that can be mounted will vary.

Hydraulic Breaker

Main Applications

- Crushed rock
- Demolition work
- Road construction

This attachment can be used for a wide range of applications including demolition of buildings, breaking up road surfaces or slag, tunnel work, rock crushing and breaking operations in quarries.

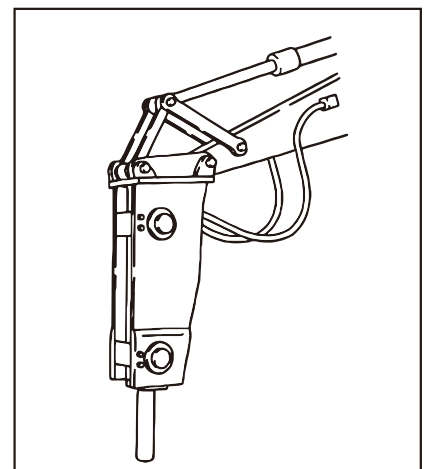

- Keep the chisel pushed perpendicularly against the impact surface when carrying out breaking operations.

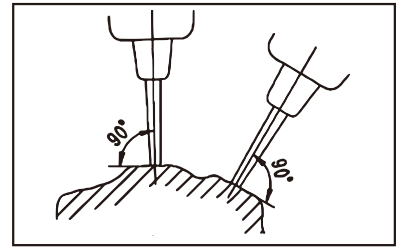

- When applying impact, push the chisel against the impact surface and operate so that the chassis rises approx. 5 cm (2 in) off the ground. Do not let the machine come further off the ground than this amount.

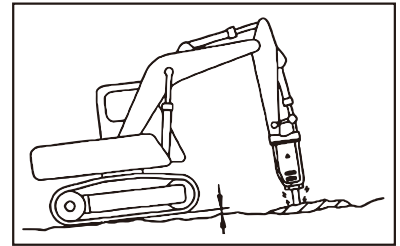

- When applying continuous impact to the same impact surface, if the chisel does not penetrate or break the surface within 1 minute, change the point of impact and carry out breaking operations closer to the edge.

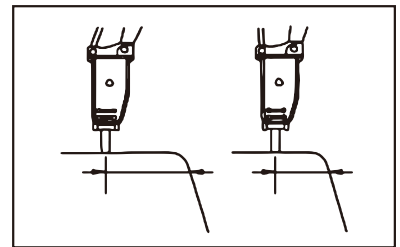

- The direction of penetration of the chisel and the direction of the breaker body will gradually move out of line with each other, always adjust the bucket cylinder to keep them aligned.

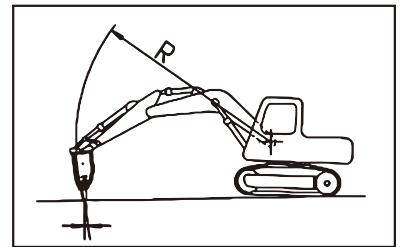

- Always keep the chisel pressed against the impact surface properly to prevent using the impact force when there is no resistance.

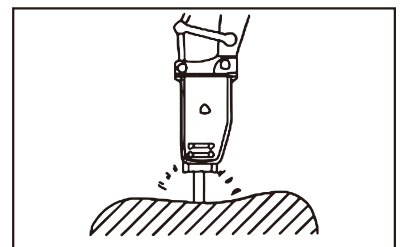

Prohibited Works

To ensure that the machine has a long life, and to ensure that operations are carried out in safety, do not operate the machine in any of the following ways.

- Do not operate all cylinders to the end of their strokes. Always leave approx. 5 cm (2 in) to spare.
- Using the mount to gather in pieces of rock



- Operations using the swing force



- Moving the chisel while carrying out impacting operations

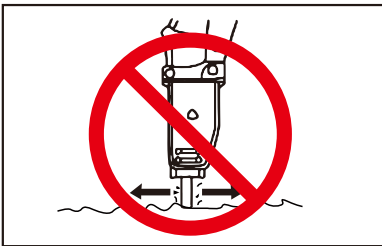

- Holding the chisel horizontal or pointed up when carrying out impacting operations

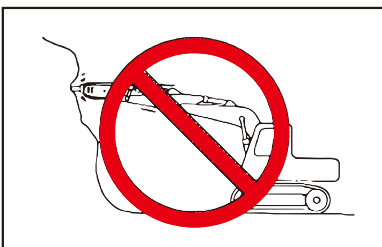

- Twisting the chisel when it has penetrated the rock

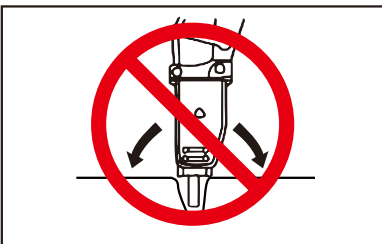

- Pecking operation

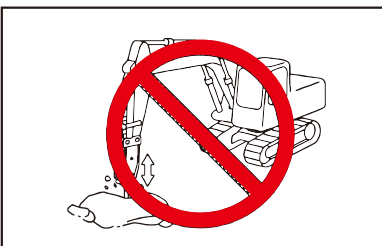

- Extending the bucket cylinder fully and thrusting to raise the machine off the ground

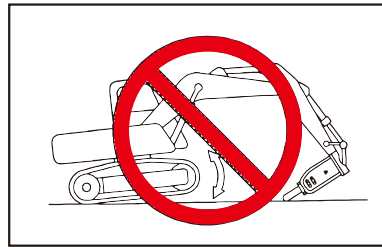

Supply Grease in the Correct Position

NOTICE

If the breaker is greased in an improper posture, it is filled with more grease than necessary. As a result, soil and sand will enter the hydraulic circuit and can damage the hydraulic components, while the breaker is in use. Therefore, be sure to grease the breaker, holding it in the right posture.

Other specific steps refer to "Hydraulic Breaker Operation and Maintenance Manual"

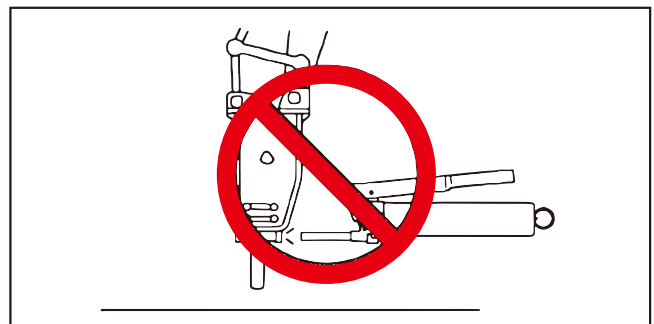
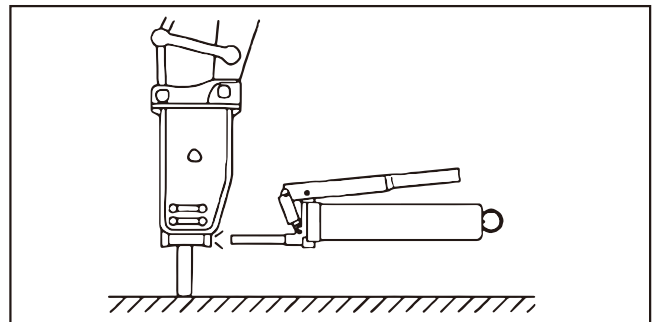

CROBA