

P4205 WOOD CHIPPER



Operator's Manual

MechMaxx

www.mechmaxx.com

Your new wood chipper is constructed with premium materials and engineered for safe, efficient operation. With proper use and maintenance, it will provide years of reliable performance.

Prepare to experience the durability to take on any job with the ease, portability, and convenience of your new Wood Chipper!

MAX performance, MAX Value, MAX Support that's Wood Chipper

- ✓ Enhanced design features come standard
- ✓ Engineered for the best user experience
- ✓ Quality metal parts are used instead of plastic
- ✓ A robust warranty supports all products
- ✓ Budget-friendly prices make it practical

TABLE OF CONTENTS

TABLE OF CONTENTS	1	INFEED CHUTE	11
SPECIFICATIONS	2	LOWER EXPULSION CHUTE	12
OVERALL DIMENSIONS	2	TAILLIGHT HOLDER	12
SAFETY SIGNS	3	KNOW YOUR MACHINE	13
SAFETY	4	OPERATION	15
GENERAL SAFETY RULES	4	ADD OIL TO ENGINE	15
PERSONAL SAFETY	4	ADD GASOLINE TO ENGINE	15
INSPECT YOUR MACHINE	4	STARTING ENGINE	15
ENGINE SAFETY	5	OPERATING	16
FUEL SAFETY	5	IDLE SPEED	17
SPECIFIC SAFETY RULES	5	STOP ENGINE	17
PRIOR TO STARTING	5	TRANSPORTING	17
OPERATION SAFETY	6	MAINTENANCE	18
FEEDING MATERIALS	6	PREVENTIVE MAINTENANCE	18
UNCLOGGING	6	REGULAR MAINTENANCE CHECKLIST	18
MOVING	6	GREASE THE INSIDE BEARING	19
MACHINE USE AND CARE	6	KNIFE AND WEAR PLATE INSPECTION	19
MAINTAINING YOUR MACHINE	7	KNIFE REMOVAL AND REPLACEMENT	20
UNPACKING THE CONTAINER	8	BELT ADJUSTMENT	20
CONTENTS SUPPLIED	9	BELT REPLACEMENT	21
TO-SCALE HARDWARE	10	CENTRIFUGAL CLUTCH TECH TIPS	21
ASSEMBLY	11	STORAGE	22
TOW BAR AND GUIDING WHEEL	11	TROUBLESHOOTING	23
AXLE	11		
WHEELS	11		

SPECIFICATIONS

Model	P4205
Engine	Ducar DH420E
Engine Type	Single Cylinder, 4-Stroke, Air-Cooled, OHV
Displacement	420 cc; 15 HP
Start	E-Start
Battery	12V 20Ah Lead-Acid
Belt	2 x V-Belts
Belt Material	Kevlar
Clutch	Centrifugal Clutch
Cutting Method	Disc
Chipping Dia.	5 in
Reduction Ratio	20:1
Blades Nos.	2 x Blade; 1 x Anvil
Blades Material	A8(5Cr8MoVSi)
Blades Type	Double Edge Blade
Discharge Chute	360-Degree Rotating
Emergency Stop	Stop Bar + Button
Feed Chute Opening Method	Hinge
Towing	Tow Bar With 2 in Coupler
Tire	19 x 7.00-8 Tubeless
Wheelbase	41.5 in
Package Method	Plywood Case
Weight (N.W./G.W.)	547/610 lbs
Packing Size (L*W*H)	43 x 31 x 50 in
Machine Warranty	2 Years
Engine Warranty	2 Years

OVERALL DIMENSIONS

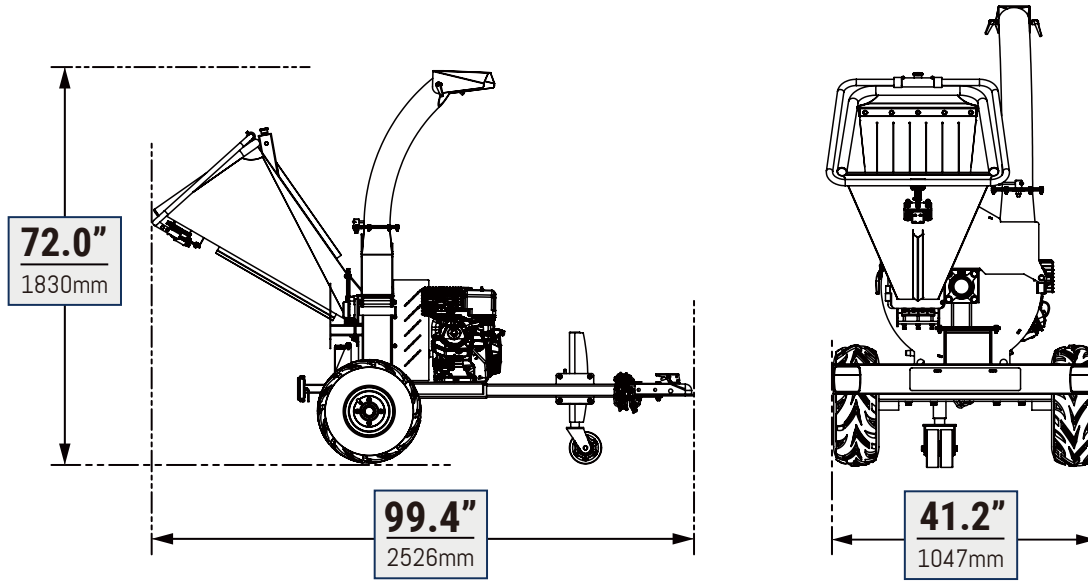

SAFETY SIGNS

The rating plate on your machine may include symbols that provide important product information or usage instructions.

⚠ DANGER ⚠

- Read and understand the operator's manual before starting and using unit.
- Keep all shields and guards in place and securely attached.
- Keep hands, feet, face, clothing and long hair away from in-feeding chute, and discharge chute while the engine is running. Rotating cutting blades inside these openings can cause serious personal injury. Material being processed may bounce back from inlet openings or be thrown from the discharge chute. Long hair or loose clothing may be pulled or sucked into the inlet openings.

⚠ WARNING ⚠

DO NOT place wood or branches over 5 in in diameter into the in-feeding bin. The blades may get stuck or jammed.

© MechMaxx 5in

- If the chipper jams or becomes clogged, immediately shut off the engine and wait for all moving parts to come to a complete stop before cleaning.
- If engine is staked because of a jam, move throttle control lever to stop position or shut off motor to "0" if equipped before clearing.
- Do not install, remove, adjust or service the discharge screen or any other part while the engine is running. Blade contact can occur.
- Do not operate on uneven ground where unit is unstable.
- To avoid a fire hazard, keep leaves, grass, and other combustible materials away from hot engine and muffler.
- Keep children and others away from area of operation.
- Do not operate on pavement, gravel or other hard surfaces since objects can ricochet and cause injury.
- Wear approved safety glasses, gloves and ear protection.

⚠ WARNING: EMERGENCY STOP ⚠

⚠ DANGER ⚠

⚠ DANGER ⚠

⚠ DANGER ⚠

BATTERY CONNECTION

Electric Start Model Only

⚠ DANGER - DO NOT RUN ENGINE WHILE OPEN ⚠

REPLACEMENT BELTS

Check belt tension before operating chipper. Belt deflection should be less than 3/8" when 10 lbs. of pressure is applied to the belt. The belt will relax after the first 1-2 hours of use. You must re-check and adjust accordingly or the belts will begin to slip and wear. For best performance check for proper belt tension every 20 hours of use.

EMERGENCY STOP

SAFETY

GENERAL SAFETY RULES

Read this manual and labels affixed to the machine to understand its limitations and potential hazards.

Be thoroughly familiar with the controls and their proper operation. Know how to stop the machine and disengage the controls quickly.

Make sure to read and understand all the instructions and safety precautions as outlined in the Engine Manufacturer's manual packed separately with your unit. Do not attempt to operate the machine until you fully understand how to properly operate and maintain the engine and how to avoid accidental injuries and/or property damage.

If the unit is loaned, rented, sold, or used by someone other than the original purchaser, provide this manual and safety training before operation. The user can prevent and is responsible for accidents or injuries that may occur to themselves, other people, and property.

Always use the correct machine for your job. Forcing the machine may cause damage. The correct machine will do the job more efficiently and safely at the rate it was designed.

PERSONAL SAFETY

Do not permit children to operate this machine at any time.

Keep children, pets, and other people not using the unit away from the work area. Be alert and shut off unit if anyone enters work area. Keep children under the watchful care of a responsible adult.

Do not operate under the influence of drugs, alcohol, or medications that impair judgment.

Dress properly. Wear heavy long pants, boots, and gloves. Do not wear loose clothing, short pants, or jewelry of any kind. Secure long hair so it is above shoulder level. Keep your hair, clothing, and gloves away from moving parts. Loose clothes, jewelry, or long hair can be caught in moving parts.

Protect eyes, face, and head from objects that may be thrown from the unit. Always wear safety goggles or safety glasses with side shields when operating.

Wear appropriate hearing protection.

Always keep hands and feet away from all moving parts during operation. Moving parts can cut or crush body parts.

Always keep hands and feet away from all pinch points.

Do not touch parts that might be hot from operation. Allow parts to cool before attempting to maintain, adjust, or service.

Stay alert, watch what you are doing, and use common sense when operating the machine.

Do not overreach. Do not operate the machine while barefoot or when wearing sandals or similar lightweight footwear. Wear protective footwear that will protect your feet and improve your footing on slippery surfaces. Keep proper footing and balance at all times. This enables better control of the machine in unexpected situations.

INSPECT YOUR MACHINE

Check your machine before starting it. Keep guards in place and in working order. Make sure all nuts, bolts, etc., are securely tightened.

Never operate the machine when it is in need of repair or is in poor mechanical condition. Replace damaged, missing, or failed parts before using it. Check for fuel leaks. Keep the machine in safe working condition.

Do not use the machine if the engine's switch does not turn it on or off. Any gasoline powered machine that can't be controlled with the engine switch is dangerous and must be replaced.

Regularly check to see that keys and adjusting wrenches are removed from the machine area before starting it. A wrench or a key that is left attached to a rotating part of the machine may result in personal injury.

Avoid accidental starting. Be sure the engine's switch is off before transporting the machine or performing any maintenance or service on the unit. Transporting or performing maintenance or service on a machine with its switch on invites accidents.

If the machine should start to vibrate abnormally, stop the engine (motor) and check immediately for the cause. Vibration is generally a warning sign of trouble.

ENGINE SAFETY

This machine is equipped with an internal combustion engine. Do not use on or near any unimproved, forest covered, or brush covered land unless the exhaust system is equipped with a spark arrester meeting applicable local, state, or federal laws.

Never start or run the engine inside a closed area. The exhaust fumes are dangerous, containing carbon monoxide, an odorless and deadly gas. Operate this unit only in a well-ventilated outdoor area.

Do not tamper with the engine to run it at excessive speeds. The maximum engine speed is preset by the manufacturer and is within safety limits. See engine manual.

Keep a Class B fire extinguisher on hand when operating this Wood chipper in dry areas as a precautionary measure.

FUEL SAFETY

Fuel is highly flammable, and its vapors can explode if ignited. Take precautions when using to reduce the chance of serious personal injury.

When refilling or draining the fuel tank, use an approved fuel storage container while in a clean, well-ventilated outdoor area. Do not smoke, or allow sparks, open flames, or other sources of ignition near the area while adding fuel or operating the unit. Never fill the fuel tank indoors.

Keep grounded conductive objects, such as tools, away from exposed, live electrical parts and connections to avoid sparking or arcing. These events could ignite fumes or vapors.

Always stop the engine and allow it to cool before filling the fuel tank. Never remove the cap of the fuel tank or add fuel while the engine is running or when the engine is hot. Do not operate the machine with known leaks in the fuel system.

Loosen the fuel tank cap slowly to relieve any pressure in the tank.

Never overfill the fuel tank. Fill the tank to no more than $\frac{1}{2}$ inch below the bottom of the filler neck to provide space for expansion as the heat of the engine can cause fuel to expand.

Replace all fuel tank and container caps securely and wipe up spilled fuel. Never operate the unit without the fuel cap securely in place.

Avoid creating a source of ignition for spilled fuel. If fuel is spilled, do not attempt to start the engine; instead, move the machine away from the spillage area and avoid creating ignition sources until vapors dissipate.

When fuel is spilled on yourself or your clothes, wash your skin and change clothes immediately.

Store fuel in containers specifically designed and approved for this purpose.

Store fuel in a cool, well-ventilated area, safely away from sparks, open flames, or other sources of ignition.

Never store fuel or a machine with fuel in the tank inside a building where fumes may reach a spark, open flame, or any other source of ignition, such as a water heater, furnace, or clothes dryer. Allow the engine to cool before storing in any enclosure.

SPECIFIC SAFETY RULES

Identify hazards and take preventive steps to avoid accidents and minimize risk. Possible hazards include, but are not limited to, moving parts, thrown objects, weight of the machine and components, and the operating environment.

PRIOR TO STARTING

Thoroughly inspect the area in which you are working, keeping it clean and free of debris to prevent tripping. Operate on a flat level ground.

Before starting your wood chipper: make sure the feed hopper and cutting housing are empty and free of all debris, check the oil level, make sure all nuts and bolts are tight, and check the air pressure in the tires.

OPERATION SAFETY

Never place any part of your body where it would be in danger if movement should occur during assembly, installation, operation, maintenance, repair, or moving. Keep bystanders and pets at least 75 feet away from the discharge chute and feed hopper.

Never place your hands, feet, or any part of your body in the chipper hopper, discharge opening, or near or under any moving part while the machine is running. Keep the area of discharge clear of people, animals, buildings, glass, or anything else that will obstruct clear discharge, causing injury or damage. Wind can also change discharge direction, so be aware. If it becomes necessary to push materials to the chipper hopper, use a small-diameter stick, not your hands.

Keep your face and body back from the chipper hopper and discharge chute to avoid injury from accidental bounce back of material.

Never reach with your hands inside the feed hopper past the rubber flap while operating the machine.

Keep combustible substances away from the engine when it is hot.

Do not tilt the machine while the engine is running

Never operate this machine without the feed hopper or discharge chute properly attached.

OPERATING ZONE

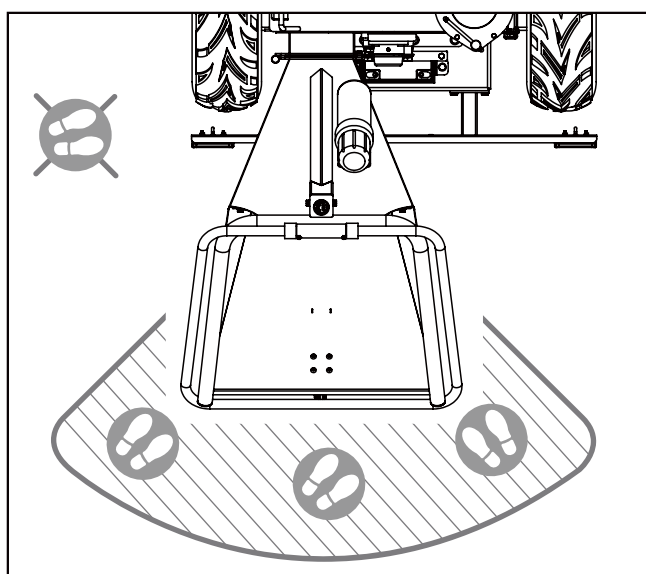

FEEDING MATERIALS

Feed only clean materials into the machine. Foreign matter such as soil, sand, grit, stones, pieces of metal, etc. will damage the sharp edge of the cutting knives. Root balls and dead wood will also dull the blades quickly.

Avoid feeding pine needles, flax and cabbage tree leaves into the machine; these stringy materials can wrap around the rotor shaft and work their way into the bearing.

Avoid feeding short, stubby pieces of wood into the machine; they tend to bounce and spin in the feed hopper. Feed these short pieces together with longer pieces. After becoming familiar with the machine, prune to suit its capabilities.

This machine is self-feeding, do not force branches into the blades. Allow the machine to automatically feed through. Allow time for the machine to reach the highest spinning revolutions before feeding the next load of branches.

UNCLOGGING

Never allow processed material to build up in the discharge area. This can prevent proper discharge and result in kickback from the chipper hopper.

Never attempt to unclog either the feed hopper or discharge chute while the engine is running. Immediately shut off the engine, allow the cutting disk to come to a complete stop, and then remove the clogged material. Inspect for damage and check for any loose parts that need repair or replacement.

Whenever you leave the operating position or if you have to remove processed material, leaves, or debris from the machine, always shut down the engine, and ensure the engine is switched to "off" to prevent accidental starting, and wait for all moving parts to come to a complete stop.

Before opening the cutting disk housing, always make sure the engine is switched off, the cutting disk is at a complete standstill, and the belt drive is disengaged.

MOVING

Move the machine at least 10 feet away from the refueling point before starting engine.

This wood chipper is for movement by hand only. Never attempt to tow the machine on public highways, roads, or thoroughfares.

Always stop the engine before moving the machine, and watch out for sharp objects that could pierce the tires.

MACHINE USE AND CARE

Position the machine in such a way that it can not move during maintenance, cleaning, adjustment, assembly of accessories or spare parts, as well as under storage.

Always use the correct machine for your job. Forcing the machine may cause damage. The correct machine will do the job better and safer at the rate for which it is designed.

Do not adjust the engine governor settings or operate the engine above the recommended speed. The governor controls the maximum safe operating speed of the engine.

This machine has two rotating cutting knives capable of amputating hands and feet and throwing objects. Keep hands and feet out of openings while machine is running. Failure to observe these safety instructions could result in serious injury or death.

Avoid contact with hot fuel, oil, exhaust fumes and hot surfaces. Do not touch the engine or muffler. These parts get extremely hot from operation. They remain hot for a short time after you turn off the unit. Allow the engine to cool before doing maintenance or making adjustments.

If the machine should start to make an unusual noise or vibration, immediately shut off the engine, disconnect the spark plug wire, and check for the cause. Unusual noise or vibration is generally a warning of trouble.

Use only attachments and accessories approved by the manufacturer. Failure to do so can result in personal injury.

Keep the engine and muffler free of grass, leaves, excessive grease or carbon build up to reduce the chance of a fire hazard.

Never douse or squirt the unit with water or any other liquid. Keep handles dry, clean and free from debris. Clean after each use.

Observe proper disposal laws and regulations for gas, oil, etc., to protect the environment.

When storing machine out of the reach of children and do not allow persons unfamiliar with the machine or these instructions to operate it. This machine can be dangerous when used by an untrained user.

MAINTAINING YOUR MACHINE

Some parts of this machine are made of plastic or rubber and should be kept away from chemicals.

Never cover the machine while the muffler is still hot.

Do not alter or adjust any part of the wood chipper or its engine that is sealed by the manufacturer or distributor. Only a qualified service technician may adjust parts that increase or decrease governed engine speed.

To maintain your machine, check for any misalignment or binding of any moving parts. Parts that are broken or worn down that may affect the machine's operation. If damage or worn parts are identified, they should be repaired before use. Many accidents are caused by poorly maintained equipment.

UNPACKING THE CONTAINER

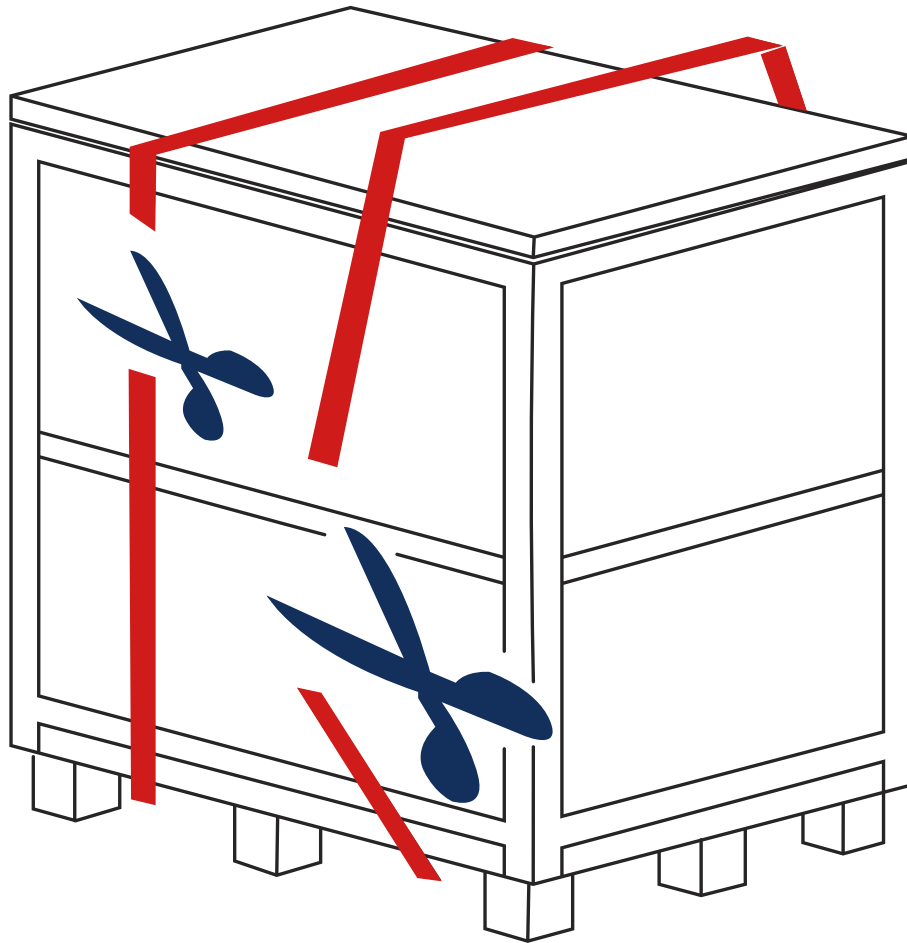

Use scissors or a knife to cut and remove the straps. Remove the wooden plate in the top. At least two people hold up the package and move it from the top.

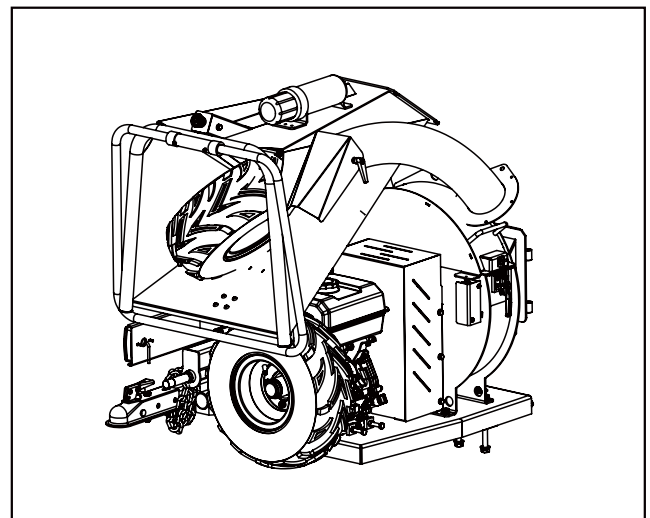
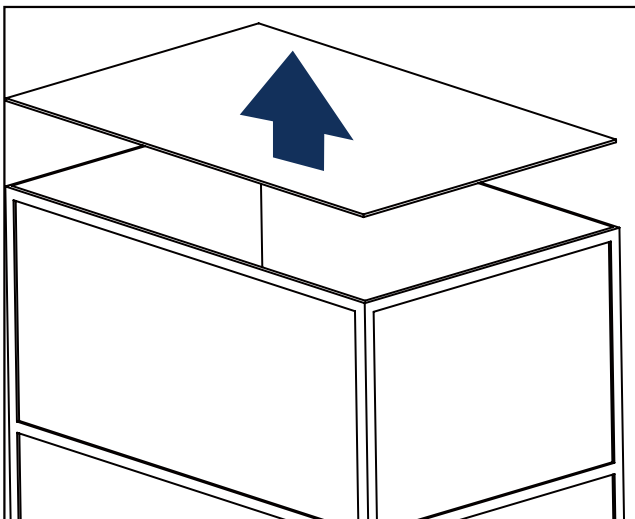

CONTENTS SUPPLIED

Your Wood chipper comes partially assembled and contains the following:

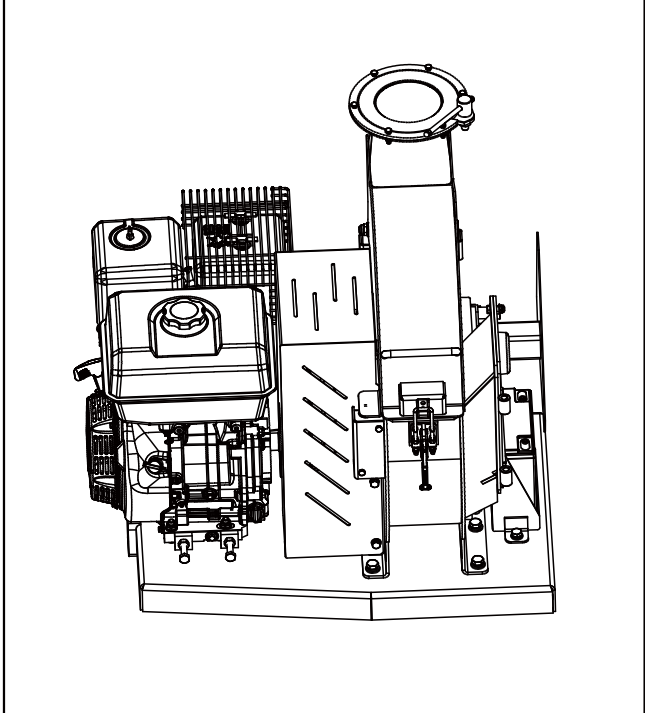

1x Engine and base frame

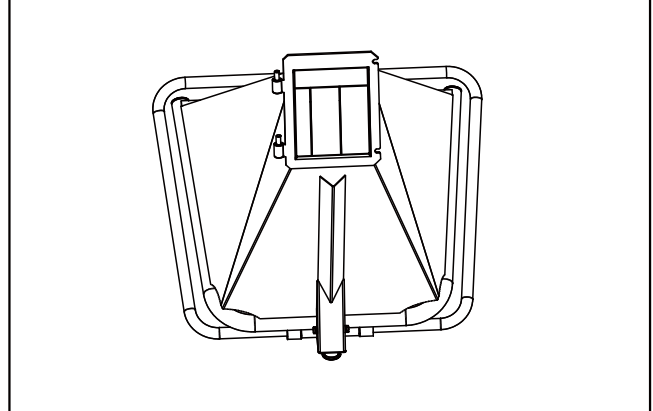

1x Infeed chute

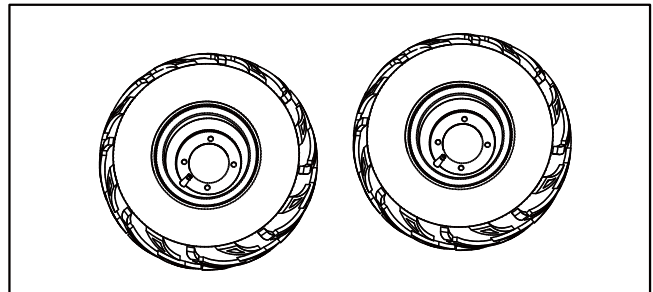

1x Wheels

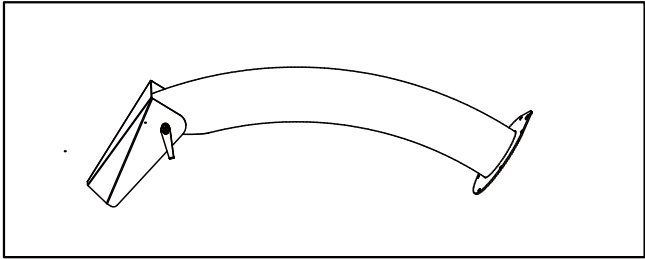

1x Lower discharging chute

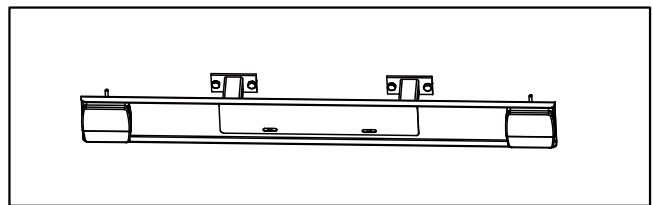

1x Taillight holder

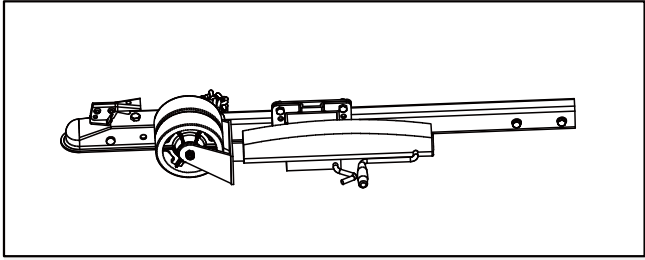

1x Tow bar and Guiding wheel

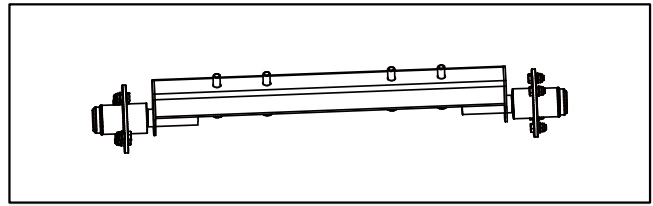



1x Axle

Verify all component and hardware quantities are correct prior to assembling the Wood chipper.

TO-SCALE HARDWARE

Hardware graphics are printed at 1:1 scale for ease of identification. Simply place the hardware over the image in the tables to verify it is the correct size.

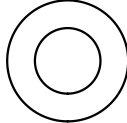
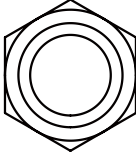
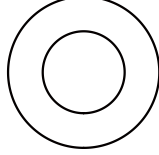
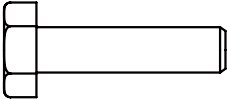
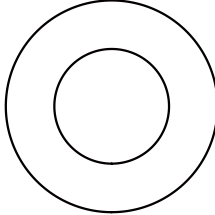
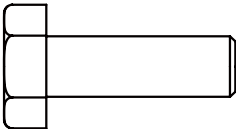
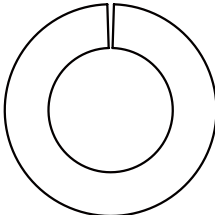
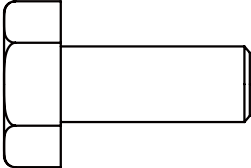
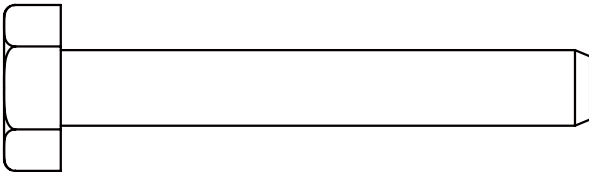
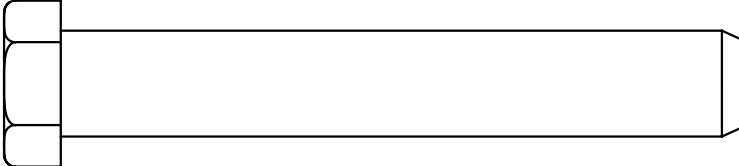
<p>Hex lock nut M6</p> <p>6X</p>		<p>Flat washer 6</p> <p>6X</p>	
<p>Hex lock nut M8</p> <p>2X</p>		<p>Flat washer 8</p> <p>2X</p>	
<p>Hex lock nut M10</p> <p>10X</p>		<p>Flat washer 10</p> <p>10X</p>	
<p>Hex bolt M6 X 25mm</p> <p>6X</p>		<p>Flat washer 14</p> <p>4X</p>	
<p>Hex bolt M8 X 25mm</p> <p>2X</p>		<p>Spring washer 14</p> <p>4X</p>	
<p>Hex bolt M10 X 25mm</p> <p>8X</p>			
<p>Hex bolt M10 X 70mm</p> <p>2X</p>			
<p>Hex bolt M14 X 90mm</p> <p>4X</p>			

ASSEMBLY

Tow bar and Guiding wheel

Attach the tow bar to the chassis using M10 x 70 hex bolts, M10 lock nuts, and 10 mm flat washers (see Figure 1).

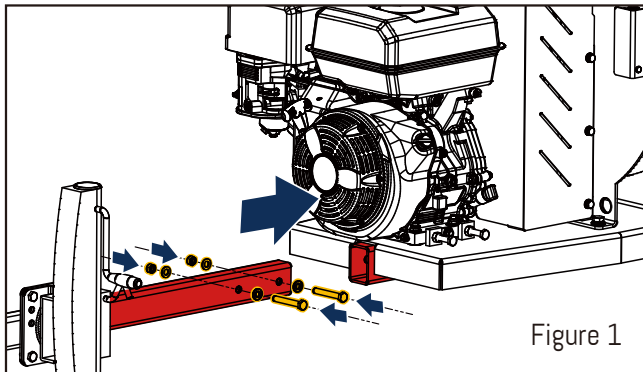

Figure 1

2X Hex lock nut M10



2X Hex bolt M10 x 70mm



2X Flat washer 10



Axle

Attach the wheel axle to the chassis using M14 x 90 hex bolts, 14 mm flat washers, and 14 mm spring washers (see Figure 2).

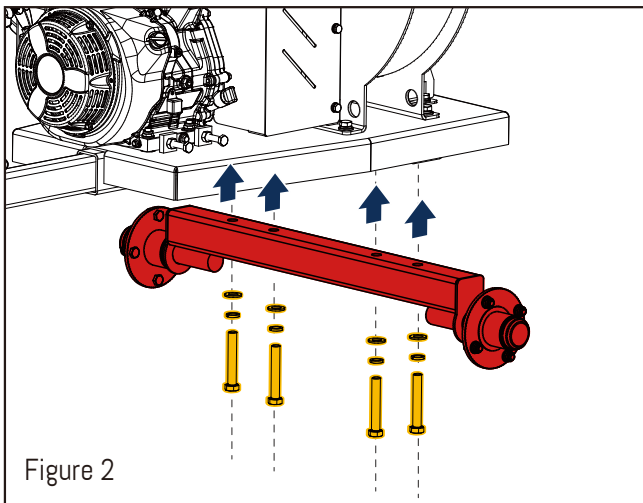

Figure 2

4X Spring washer 14



4X Hex bolt M14 x 90mm



4X Flat washer 14



Wheels

Attach the wheels to the wheel axles using M10 x 25 hex bolts, M10 lock nuts, and 10 mm flat washers (see Figure 3).

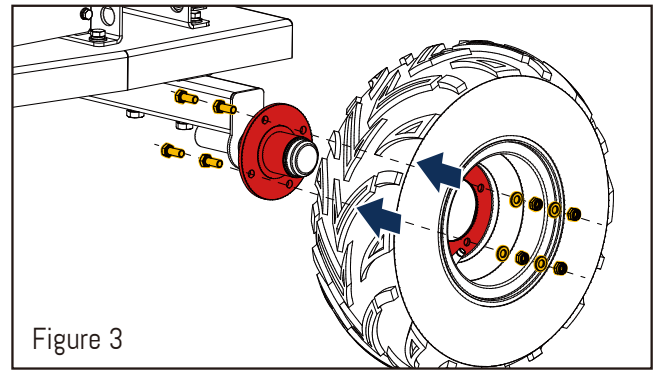

Figure 3

4X Hex lock nut M10



4X Hex bolt M10 x 25mm



4X Flat washer 10



Infeed chute

Attach the infeed chute to the chipper disc housing using M8 x 25 hex bolts, M8 lock nuts, and 8 mm flat washers (see Figure 4).

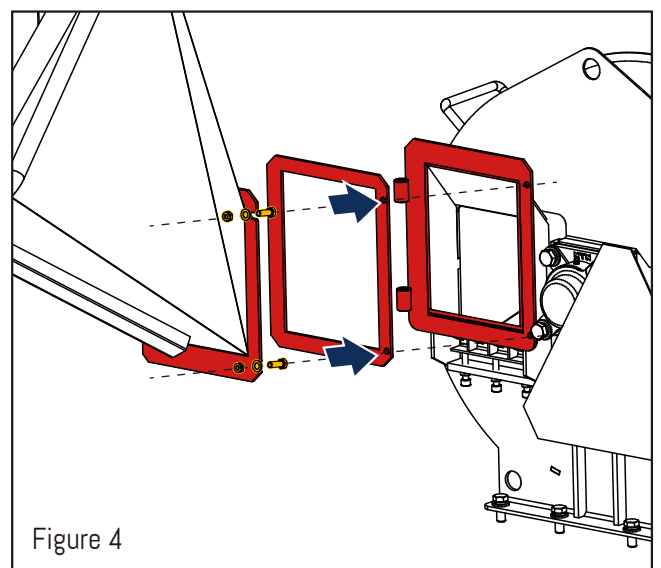

Figure 4

2X Hex lock nut M8



2X Hex bolt M8 x 25mm



2X Flat washer 8



Lower expulsion chute

Attach the discharge chute to the chipper disc cover using M6 x 25 hex bolts, M6 lock nuts, and 6 mm flat washers (see Figure 5).

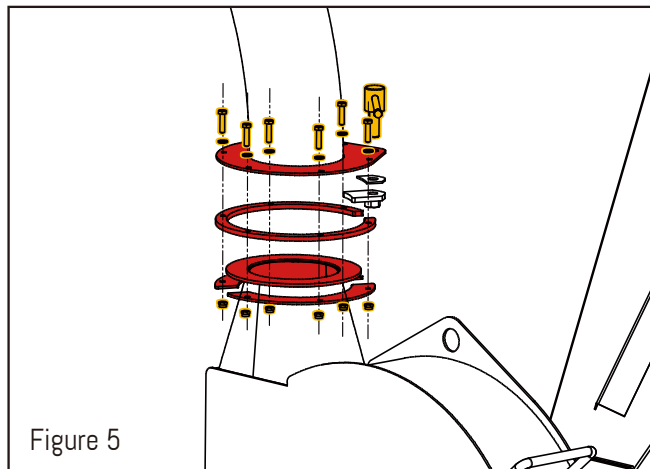

Figure 5

6X Hex lock nut M6



6X Hex bolt M6 x 25mm



6X Flat washer 6



Taillight holder

Attach the taillight holder to the chassis using M10 x 25 hex bolts, M10 lock nuts, and 10 mm flat washers (see Figure 6).

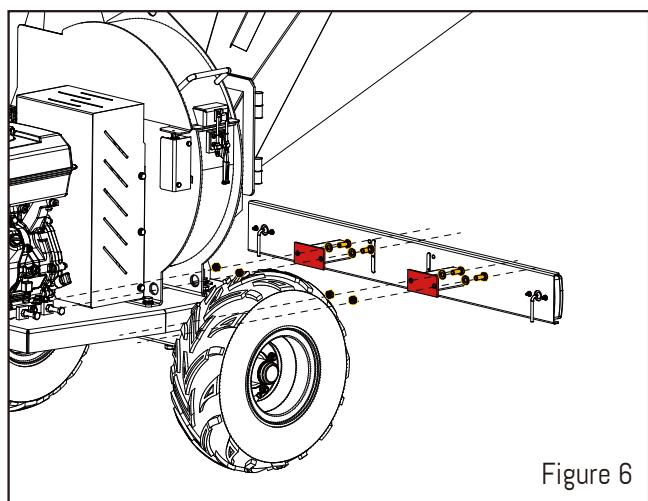

Figure 6

4X Hex lock nut M10



4X Hex bolt M10 x 25mm



4X Flat washer 10



Emergency Stop

The Emergency Stop wiring is located near the engine. Simply connect the wires as required. (The machine has two emergency-stop wires—one for the button and one for the lever. The wiring is the same for both.)

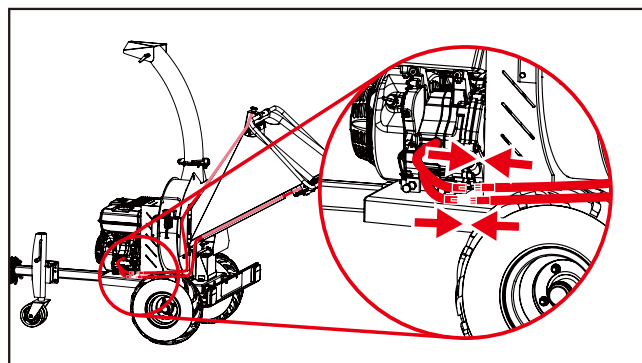

Battery Wiring

There are red and blue markings above the battery. Connect the red wire to the positive terminal (red) and the black wire to the negative terminal (blue).

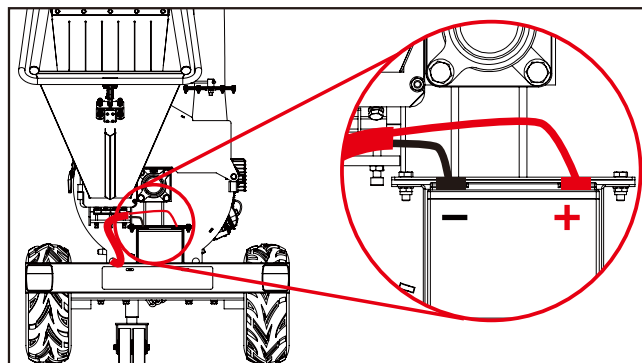

Tail Light Wiring

Once the tail light is properly installed, guide the wiring through the machine frame toward the trailer tongue. Then connect the wiring to the towing vehicle using the appropriate connector.

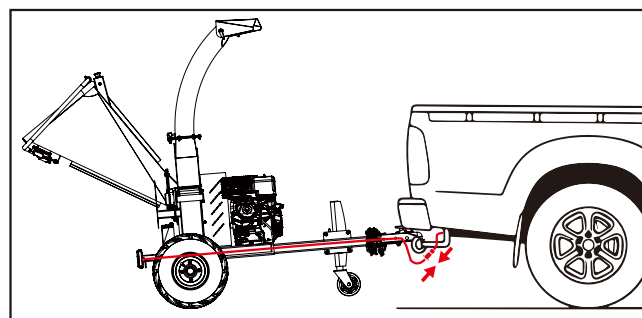

KNOW YOUR MACHINE

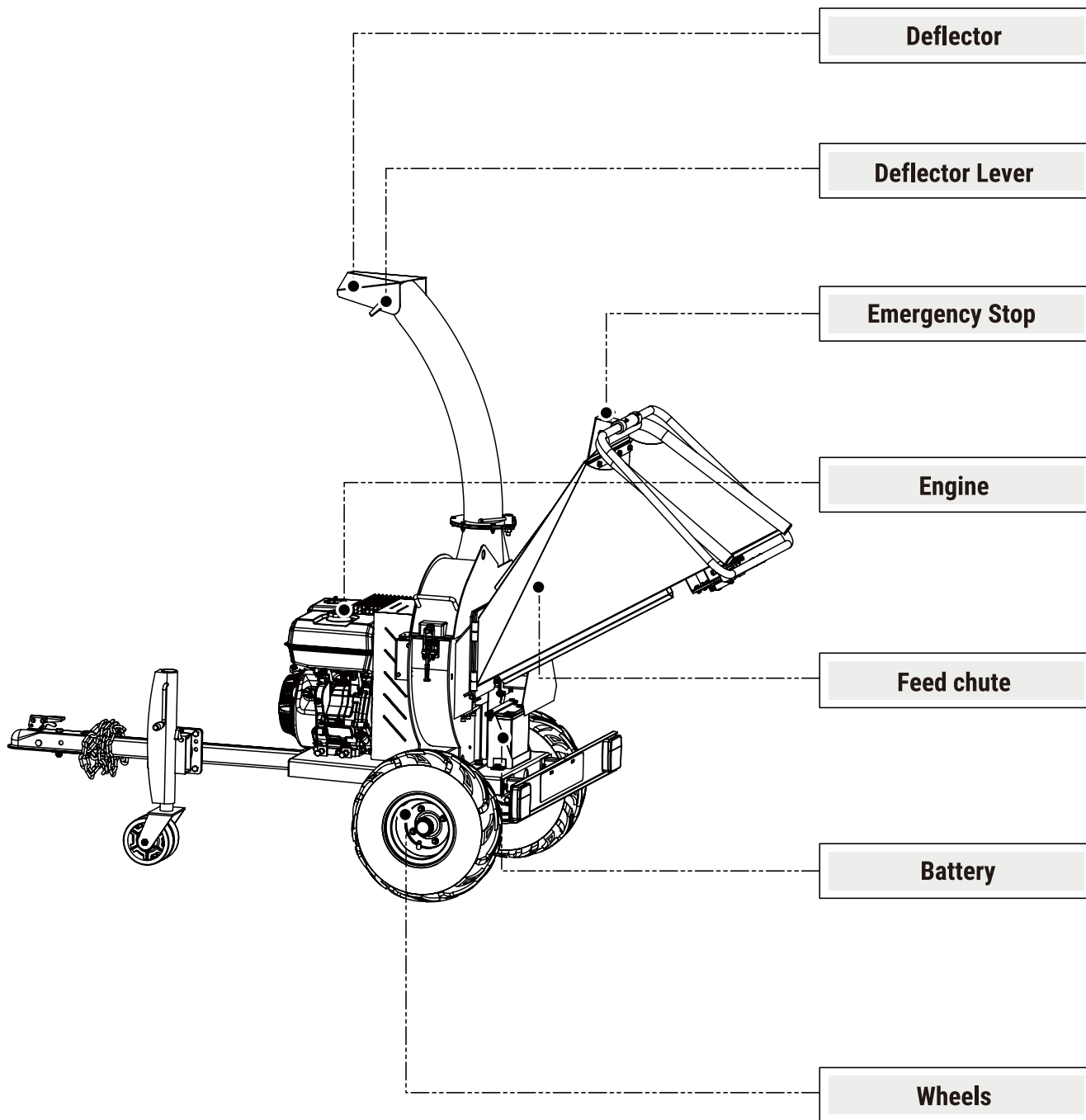

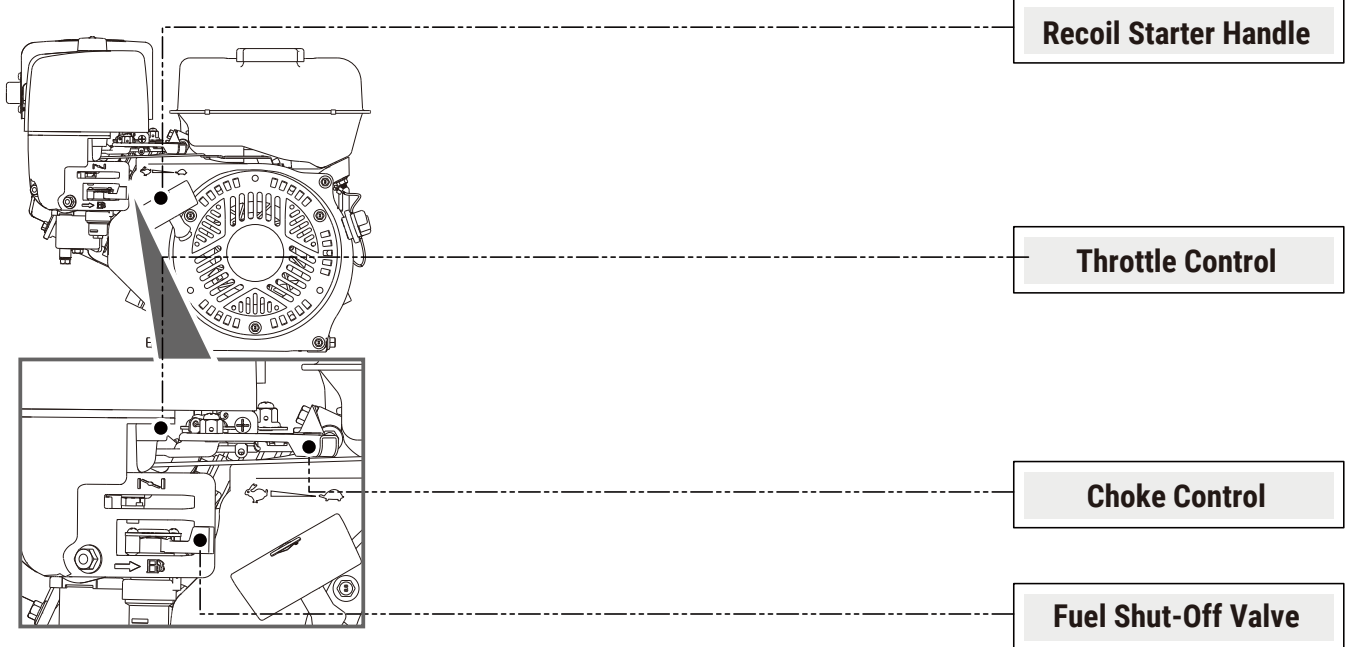

OPERATION



Note: The engine is shipped without oil. Do not start the engine before adding oil. Do not overfill; check the engine oil level daily and add as needed.

ADD OIL TO ENGINE

1. Ensure the wood chipper is on a flat, level surface.

2. Remove the oil fill cap/dipstick and add oil up to the FULL mark. (See engine manual for oil capacity, recommended oil type, and location of the fill cap.)

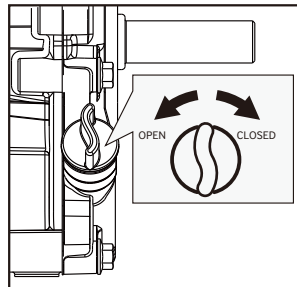

3. Using a funnel, add oil up to the FULL mark on the dipstick. (See engine manual for oil capacity, oil recommendation, and location of fill cap.)

ADD GASOLINE TO ENGINE



Gasoline is highly flammable and explosive. You can be burned or seriously injured when handling fuel. Use extreme care when handling gasoline.



Fill the fuel tank outdoors, never indoors. Gasoline vapors can ignite if they collect inside an enclosure. Explosion can result.

1. With the engine off and cool (at least two minutes), remove the fuel filler cap and fill the tank. (See engine manual for fuel capacity, recommended fuel type, and the location of the fuel cap.)

2. Fill the fuel tank outdoors. Gasoline vapors can ignite in enclosed spaces.



IMPORTANT: DO NOT OVERFILL!

This equipment and/or its engine may include evaporative emissions control system components that are required to meet EPA and/or CARB regulations and will only function properly when the fuel tank is filled to the recommended level. **Overfilling may cause permanent damage to evaporative emissions control system components. Filling to the recommended level ensures a vapor gap required to allow for fuel expansion. Pay close attention while filling the fuel tank to ensure that the recommended fuel level inside the tank is not exceeded. Use a portable gasoline container with an appropriately sized dispensing spout when filling the tank. Do not use a funnel or other device that obstructs the view of the tank filling process.**

3. Reinstall and tighten the fuel cap, and clean up any spilled fuel.

STARTING ENGINE

1. Move the engine switch to the ON position.



2. Open the fuel shut-off valve.

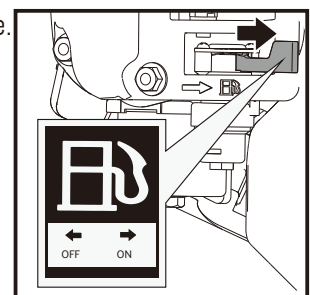

3. Move the choke lever to the CLOSED position.

» If the engine is hot, closing the choke is not necessary.

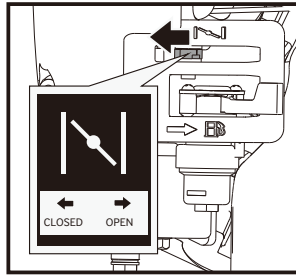

4. Move the throttle lever slightly to the FAST speed.

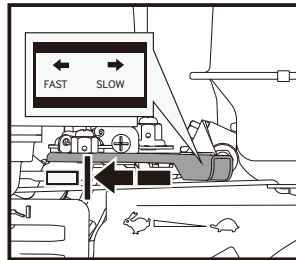

5. Pull the recoil starter until resistance is felt, then slowly release it to the home position before pulling quickly to start.



Rapid retraction of the starter cord (kick-back) may pull your hand and arm toward the engine, potentially resulting in broken bones, fractures, or bruises.

OPERATING

After the engine warms up, pull the throttle lever to accelerate engine speed.

The wood chipper can process a wide variety of dry and green organic materials, including branches, stalks, vines, leaves, roots, and vegetable matter. The maximum capacity is 5-inch diameter branches, though this may vary depending on the type and hardness of the wood. Rotating the branch as you feed it into the machine can improve performance.

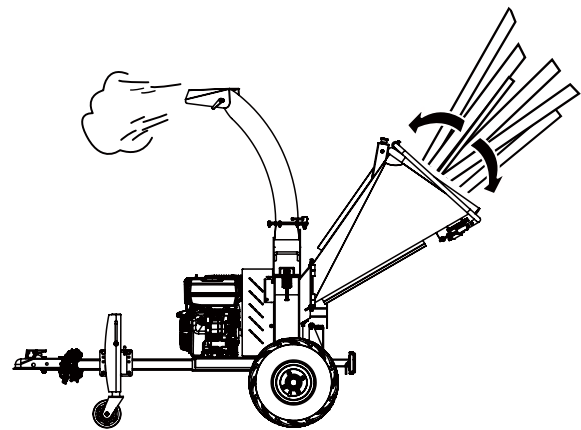

Feed limbs or branches through cut-end first, leaving the bushy head on. This helps guide the limb down the feed hopper and reduces spinning and bouncing of small pieces back up the feed hopper. Some side branches may require pre-cutting so that they self-feed more efficiently.

It is always advisable to process freshly cut materials, as wooden branches get very hard, they become springy when dried out and can make the knives dull more quickly.

While operating the machine, keep a wooden stick handy, approximately 1 inch in diameter by 2 feet long. This stick will be useful to push in short, brushy and very leafy materials and keep the feed hopper clear.

Do not force material into the machine. If it does not chip well, the chipper knives may need sharpening or to be replaced, or the gap between the knives and the wear plate needs adjusting.

Do not overload the machine by feeding too much material in to the feed hopper at one time. If you hear the speed of the engine decreasing, immediately stop feeding material in to the machine. Do not resume feeding material into the machine until the engine has returned to full speed.

The wood chipper can clog up with soft, wet, or fibrous materials. However, if you feed soft materials intermittently with branches, there should be no problem, as the wood chipper tends to clean out any residue left in the machine.

If any stringy material wraps around the rotor shaft, remove it before it works its way into the bearing.

If the wood chipper stalls due to overloading or clogging, turn off the engine switch and wait until the cutting disk is completely stopped and the belt drive is disengaged. Allow the engine to completely cool and switch the engine to off. Open the housing cover to clear and remove all the materials from the housing. Lock the housing cover, switch the engine to the on position, and start the machine again to resume operation.

As the discharge material piles up, move the chipper away from the pile. This will keep the material from backing up the discharge chute. Do not position the deflector vertically, as this will reduce the airflow, impeding the discharge and causing blockage.



Make sure the machine is level and stable to avoid unnecessary vibrations.



Do not open the housing cover unless the engine and cutting disk are completely stopped and the belt drive is disengaged.





To shut down the machine, move the throttle control lever to idle speed, turn the engine switch to the OFF position, and it will gradually come to a standstill.

IDLE SPEED

Set the throttle control lever to the SLOW position to reduce stress on the engine when chipping is not being performed. Lowering the engine speed will help extend the life of the engine, as well as conserve fuel and reduce noise level.

STOP ENGINE

To stop the engine in an emergency, simply turn the engine switch to the OFF position. Under normal conditions, use the following procedure:

1. Move the throttle lever to the SLOW () position.
2. Let the engine idle for one or two minutes.
3. Turn the engine switch to the OFF position.
4. Turn the fuel valve lever to the OFF () position.



Sudden stopping at a high speed under a heavy load is not recommended. Engine damage may result.



Do not move the choke control to CLOSE to stop the engine. Backfire or engine damage may occur.

Wait until the machine completely stops. Allow the engine to completely cool. Then clean out the interior of the machine and its discharge chute.



Do not disengage the belt drive with the machine running. This will cause friction and vibration on the belt drive.

TRANSPORTING

Your wood chipper is equipped with two large pneumatic wheels for easy maneuverability. To move the unit, grip the handles and tilt the wood chipper slightly, ensuring that the oil tank cover is securely tightened beforehand.

MAINTENANCE

Maintaining your Wood chipper will ensure long life to the machine and its components.

PREVENTIVE MAINTENANCE

1. Turn off the engine. The engine must be cool.
2. Keep the engine's throttle lever in its SLOW position and remove the spark plug wire from the spark plug and secure.
3. Inspect the general condition of the wood chipper. Check for loose screws, misalignment or binding of moving parts, cracked or broken parts, and any other condition that may affect its safe operation.
4. Remove all debris from the Wood chipper with a soft brush, vacuum, or compressed air. Then use a premium quality lightweight machine oil to lubricate all moving parts.
5. Replace the spark plug wire.



Never use a pressure washer to clean your Wood chipper. Water can penetrate tight areas of the unit and cause damage to spindles, pulleys, bearings, or the engine.



Shut down the engine, wait for all moving parts to come to a complete stop, remove the spark plug wire, and then wait five minutes before performing maintenance on the chipper.

REGULAR MAINTENANCE CHECKLIST



The service intervals shown are the maximum under normal operating conditions. Increase frequencies under extremely dirty or dusty conditions.

Procedure	Before each use	Every 8-10 Hours	Every 40 Hours
Check engine oil level	▲		
Check general equipment condition	▲		
Check that cutting disk turns freely (with a long stick only)	▲		
Visually inspect knife for damage	▲		
Check knife and wear plate for sharpness		▲	
Check knife and wear plate attachment screws		▲	
Check for any loose nut and bolts		▲	
Check knife to wear plate gap		▲	
Check belt tension and condition	1 st time 1 hour	▲	
Check tire pressure			▲
Change engine oil	1 st time 5 hours		▲
Inspect or replace drive belt			▲
Inspect or replace spark plug			▲
Inspect or replace air filter and precleaner			▲

Grease the inside bearing

1. Loosen the lock nut which holds the discharge chute on the machine.
2. Slide down the fixing plate under the lock nut.

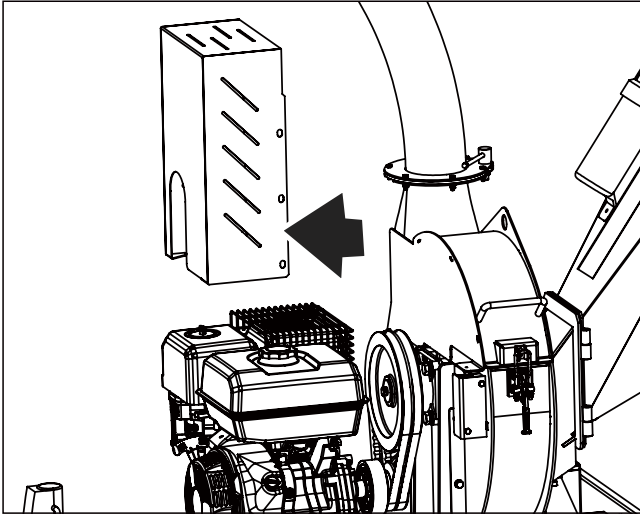

3. Open, then grease the inside bearing.

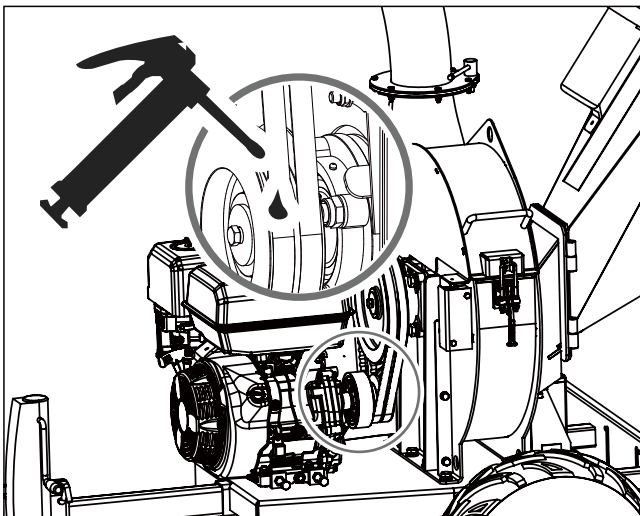

If the machine's cutting disk strikes a foreign object, or if the machine begins to make an unusual noise or vibrates excessively, immediately shut off the engine. Allow the cutting disk to come to a complete stop. Switch the engine to "off" to avoid any accidental start. Then perform the following steps:



- Inspect for damage.
- Repair or replace damaged parts.
- Check for any loose parts and tighten to ensure continued safe operation.

KNIFE AND WEAR PLATE INSPECTION

Routinely inspect both the knives (for sharpness) and the wear plate (for edge condition) to ensure that your wood chipper is operating at full efficiency. Using dull knives or a rounded wear plate will decrease performance and cause excessive vibration that will damage the machine and make chipping difficult for the operator.

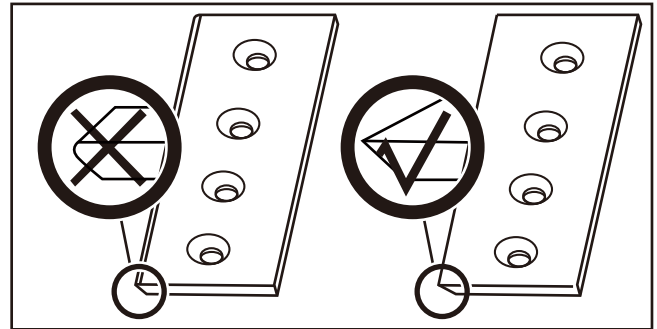
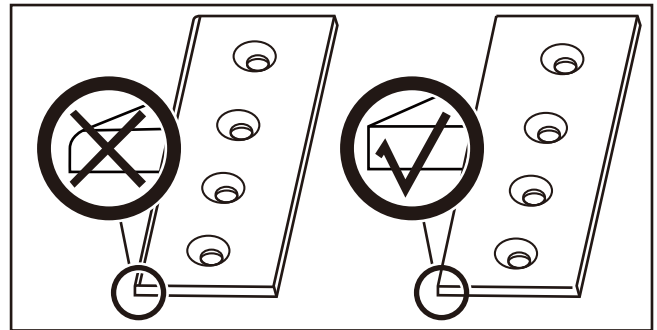

KNIFE REMOVAL AND REPLACEMENT

This Wood chipper is equipped with two chipper knives mounted on the cutting disk. When the knives get dull or show visible nicks, the machine will lose its self-feeding action and the material has to be pushed in. Often it comes out in long strips. Replace the knives by following steps.

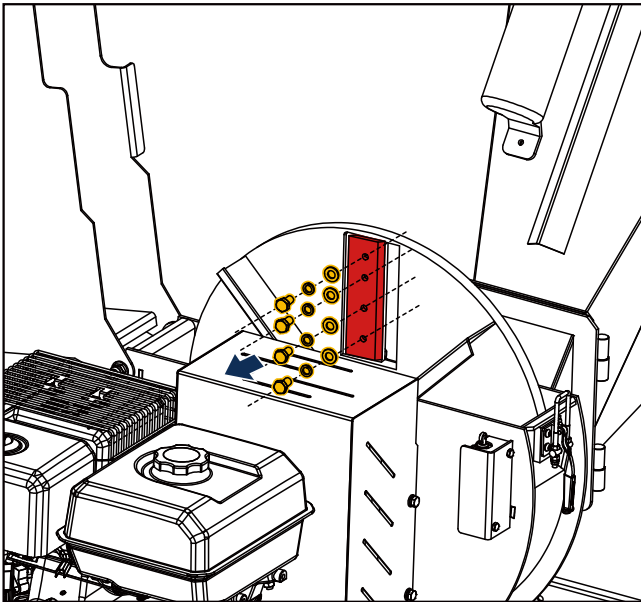

1. Remove the discharge chute.
2. Rotate the cutting disc until the blade can be seen from the feed hopper side.
3. Remove the bolts, nuts that fix the blade.



Be careful and wear gloves when working near the knives.

4. Remove the dull or damaged knives and visually inspect the cutting disk slot and knives mounting area. Make sure they are clean and that the placement knives will be able to mount flush against the cutting disk. Remount new or sharpened knives with the knife edges facing up.



If the cutting disk surface is not cleaned properly and the knives are not mounted flush on the cutting disk, the knives could crack when the hardware is tightened.

The clearance between the knives and wear plate should be approximately 0.04 inch at the position of closest to the rotor shaft and 0.12 inch at the position of farthest to the rotor shaft. They are tapered out slightly to allow for a small amount of movement in the cutting disk as it bites into the wood.

Make sure that all locknuts are tightened properly. Then turn the cutting disk with a long wooden stick to make sure it rotates freely.

BELT ADJUSTMENT

The belt on your chipper should deflect 3/8" under three pounds of pressure as shown in fig. 1 below. If it doesn't, adjust per the following directions.

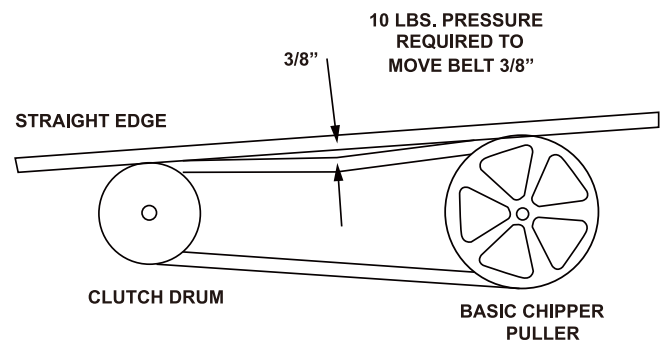

1. Remove belt guard.
2. Loosen engine bolts.
3. Tighten or loosen the nut until you have the correct tension as shown in fig. 1.
4. Retighten engine bolts.
5. Check alignment of the clutch with the drive pulley by placing a straight edge across both faces as shown in fig. 2. If adjustment is necessary, correct alignment by moving rotor pulley in or out on the rotor shaft. Do not make adjustment by moving the clutch on the engine shaft.
6. Replace belt guard.

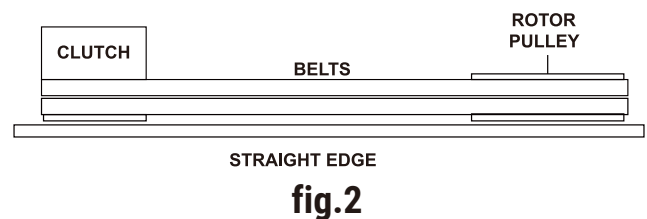

BELT REPLACEMENT

1. To replace the belt, follow the belt adjustment directions above.
2. After loosening the engine bolts, remove the old belts and replace them with new ones. Always replace both belts, as they come in a matched set. This is required for proper operation.
3. Set the belt tension and alignment according to the instructions above.



NOTE: Check and re-tighten belts after initial break-in period, one hour of use.

CENTRIFUGAL CLUTCH TECH TIPS

The shoes and springs on the clutch are normal wear items. If you notice decreased performance of the clutch, they should be checked and replaced if necessary.

The clutch on your machine is designed for rugged, dependable service. However, it is important to understand the limitations of a clutch. A clutch is designed to provide load-free starting of the engine and allow slippage under excessive overloading of the driven application. These features help protect the engine from damage, such as broken crankshafts and starters.

The clutch obtains its power from engine RPMs. The lower the engagement speed and the higher the maintained engine speed, the more torque the clutch can transfer to the driven unit. Do not operate at less than full RPMs.

At engine start-up, your chipper's engine operates under no load until approximately 1,000–1,200 RPMs, at which point the centrifugal clutch engages and begins driving the rotor.

The proper rotor speed is 1,500 RPM \pm 200 RPM when the engine is at full RPM.

Do not tamper with the engine's governor setting. The governor controls the maximum safe operating speed and protects the engine. Over-speeding the engine is dangerous and will cause damage to the engine and other moving parts of the machine. See your authorized dealer for engine governor adjustments.

Become familiar with successful operating conditions and avoid those that can overload or damage the machine.

Do not overload or attempt to chip material beyond the manufacturer's recommendation. Personal injury or machine damage could result.

Learn to recognize the sound of the machine when it is overloaded. If the machine becomes jammed due to overloading or any other cause, stop the machine immediately.

If the machine jams and the engine is not stopped, it can:

Burn the belt.

Ruin the clutch.

Only operator experience will determine how quickly you can successfully feed limbs into the machine.

Clutch damage can be costly and is not covered under warranty. For this reason, immediately shut off the machine if it becomes jammed.

STORAGE

If your Wood chipper will not be used for more than 30 days, follow the steps below to prepare your unit for storage:

1. Drain the fuel tank completely. Stale fuel has high gum content and can clog the carburetor and restrict fuel flow.
2. Start the engine and allow it to run until it stops. This ensures no fuel is left in the carburetor and helps prevent deposits from forming inside, which can damage the engine.
3. Drain the oil from the engine while it is still warm. Refill with fresh oil of the grade recommended in the engine manual.
4. Allow the engine to cool. Remove the spark plug and put 60 ml of SAE-30 high-quality engine oil into the cylinder. Pull the starter rope slowly to distribute the oil. Replace the spark plug.



Remove the spark plug and drain all oil from the cylinder before attempting to start the unit after storage.

5. Use clean cloths to clean off the outside of the Wood chipper and to keep the air vents free from obstructions.



Do not use strong detergents or petroleum based cleaners when cleaning plastic parts. Chemicals can damage plastics.

6. Store your wood chipper in an upright position in a clean, dry building with good ventilation.



Do not store your wood chipper with fuel in a non-ventilated area where fuel fumes could reach flames, sparks, pilot lights or any ignition sources.

Use only approved fuel containers.

TROUBLESHOOTING

Problem	Cause	Remedy
Engine fails to start	<ol style="list-style-type: none"> 1. Spark plug wire is disconnected. 2. Out of fuel or stale fuel. 3. Engine and/or Fuel valve is not in ON position. 4. Choke lever is not in CLOSE position. 5. Blocked fuel line. 6. Fouled spark plug. 7. Engine flooding. 	<ol style="list-style-type: none"> 1. Attach spark plug wire securely to spark plug. 2. Fill with clean, fresh gasoline. 3. Engine and Fuel valve must be in ON position. 4. Choke lever must be in CLOSE position for a cold start. 5. Clean fuel line. 6. Clean, adjust gap, or replace. 7. Wait a few minutes to restart, but do not prime.
Engine runs erratically	<ol style="list-style-type: none"> 1. Spark plug wire is loose. 2. Unit running with Choke lever in CLOSE position. 3. Blocked fuel line or stale fuel. 4. Vent plugged. 5. Water or dirt in fuel system. 6. Dirty air cleaner. 7. Improper carburetor adjustment. 	<ol style="list-style-type: none"> 1. Connect and tighten spark plug wire. 2. Move choke lever to OPEN position. 3. Clean fuel line. Fill tank with clean, fresh gasoline. 4. Clear vent. 5. Drain fuel tank. Refill with fresh fuel. 6. Clean or replace air cleaner. 7. Refer to engine manual.
Engine overheats	<ol style="list-style-type: none"> 1. Engine oil level low. 2. Dirty air cleaner. 3. Air flow restricted. 4. Carburetor not adjusted properly. 	<ol style="list-style-type: none"> 1. Fill crankcase with proper oil. 2. Clean air cleaner. 3. Remove housing and clean. 4. Refer to engine manual.
Chipping action seems too slow, cutting disk stalls, or no material is discharged when engine is running	<ol style="list-style-type: none"> 1. Engine speed is too slow causing belt to slip. 2. Drive Belt is loose or damaged. 3. Knives are dull or damaged. 4. Cutting disk is jammed by debris from the feed hopper and discharge chute. 5. Discharge chute is clogged. 	<ol style="list-style-type: none"> 1. Run the engine at full throttle. 2. Tighten or replace drive belt. 3. Sharpen or replace knives. 4. Remove any built-up debris and turn cutting disk with a wooden stick to be sure it turns freely. 5. Clean out debris.

Problem	Cause	Remedy
The belt frays or rolls over the pulley	<ol style="list-style-type: none">1. Rotor drive pulley groove may be nicked.2. Drive belts may be stretched.3. Pulleys may be misaligned.	<ol style="list-style-type: none">1. Check drive belts for wear and hard spots. File off any nicks on the pulley.2. Replace drive belts.3. Adjust pulleys.
When chipping, branch seems to vibrate and move about excessively with unusual noise	<ol style="list-style-type: none">1. Knives are dull or damaged.2. Knives are not properly seated on the cutting disk.3. The gap between the knives and wear plate is too large.4. Rotor is overloaded with material.	<ol style="list-style-type: none">1. Sharpen or replace knives.2. Loosen the knife mounting screws, reset the knives, and tighten the screws.3. Adjust the gap.4. Allow unit to clear itself before adding more material to the hopper.
Chipper Knives are hitting the wear plate	The gap between the knives and wear plate is set incorrectly.	Adjust the gap.
The machine's wheels track left or right while being towed	Low tire pressure.	Add air to tires.

MechMaxx

info@mechmaxx.com