

# SG30 PRO PTO STUMP GRINDER



## Operator's Manual

**MechMaxx**

[www.mechmaxx.com](http://www.mechmaxx.com)



Your new PTO Stump Grinder offers quality construction, and is easy and safe to operate. With proper use and care, it is designed to give you many years of dependable service.

Prepare to experience the durability to take on any job with the ease, portability, and convenience of your new PTO Stump Grinder !

**MAX performance, MAX value, MAX support that's SG30PRO PTO Stump Grinder**

- ✓ Enhanced design features come standard
- ✓ Engineered for the best user experience
- ✓ Quality metal parts are used instead of plastic
- ✓ A robust warranty supports all products
- ✓ Budget-friendly prices make it practical

---

## TABLE OF CONTENTS

---

TABLE OF CONTENTS	1	SET-UP PROCEDURES	12
SPECIFICATIONS	2	TRIMMING THE PTO SHAFT	12
OVERALL DIMENSIONS	2	DETERMINE DRIVESHAFT LENGTH	12
3-POINT HITCH DIMENSIONS	3	PTO SHAFT CLUTCH RUN-IN	13
SAFETY SIGNS	3	FLYWHEEL TOOTH TORQUING	14
SAFETY	4	OPERATION	15
GENERAL SAFETY RULES	4	STARTUP	16
PERSONAL SAFETY	4	PREPARATION FOR USE	16
UNPACKING THE CONTAINER	6	ATTACH STUMP GRINDER TO TRACTOR	16
CONTENTS SUPPLIED	7	FIRST TIME USER TIPS	17
TO-SCALE HARDWARE	8	FIELD OPERATION	18
ASSEMBLY	9	STUMP GRINDING PROCEDURE	19
TOP LINK BRACKET	9	MACHINE USE AND CARE	20
DEFLECTOR	9	MAINTENANCE	22
CHAINSAW HOLDER	9	REPLACING TEETH	22
MANUAL TUBE	10	GREASING	22
KNOW YOUR MACHINE	11	TROUBLESHOOTING	23
		STORAGE	24
		PARTS DIAGRAM	25
		PARTS LIST	26

## SPECIFICATIONS

Model	SG30 PRO
Flywheel Diameter	30 in
Flywheel Thickness	1 in
Carbide Tip	44 pcs
Carbide Tip Material	YG11C
Tip Holder Material	42CrMo
PTO HP Required	40-100 HP
PTO Shaft (Included Shipping)	1-3/8" 6 Spline Tractor and Implement Ends PTO Driveline Shaft with Slip Clutch
Friction Torque Limiter (Slip Clutch)	Included
Mounting	3 point hitch Cat. 1 & 2
PTO Input	540 RPM
Max. Torque	1200 N·m
PTO Shaft Weight	44 lbs
Dimensions	38 x 32.7 x 32.2 in
Packing	Iron frame + Carton
Weight (N.W/G.W.)	641 / 750 lbs

### OVERALL DIMENSIONS

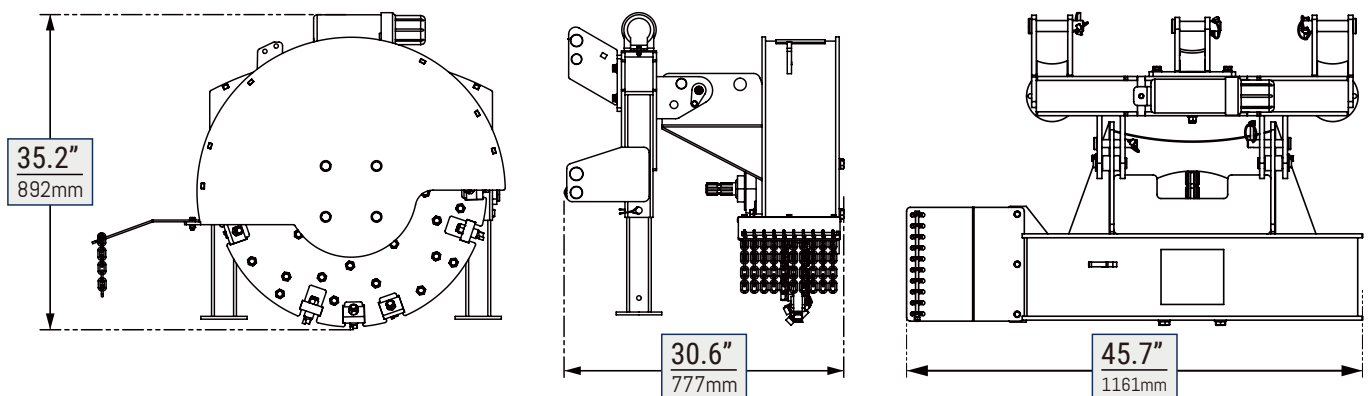

3-POINT HITCH DIMENSIONS

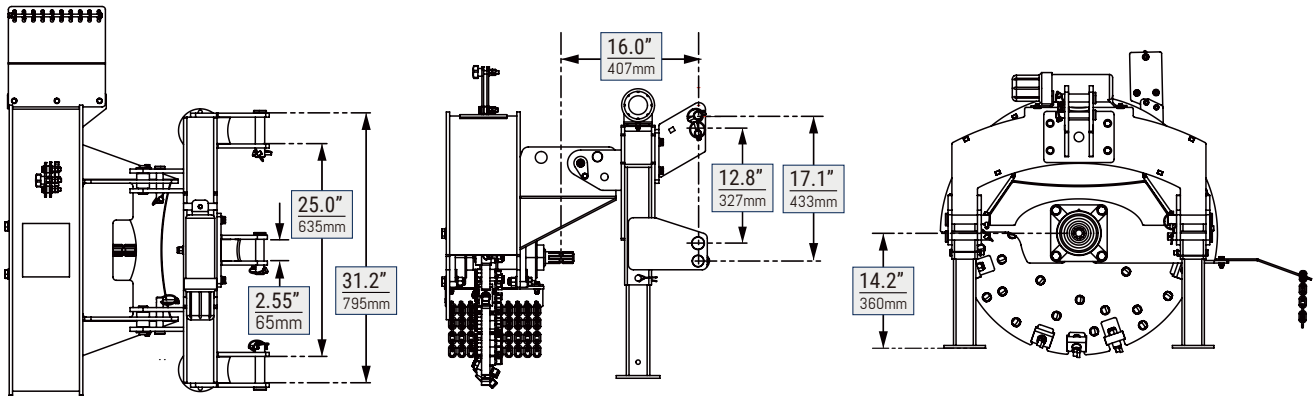

**SAFETY SIGNS**

The rating plate on your machine may show symbols. These represent important information about the product or instructions on its use.

**⚠ DANGER ⚠**

**ROTATING KNIVES HAZARD**



To prevent serious injury or death from rotating knives:

- DO NOT go under frame when rotor is turning or engine is running. Keep others away.
- Disconnect & lockout power source BEFORE adjusting or servicing.
- Keep hands, feet, hair, and clothing away from moving parts.

**⚠ WARNING**

The PTO Driveline **MUST** be measured and cut (if required) as per the Owner's Manual. Failure to do so will result in damage to both the tractor and the implement.

**⚠ DANGER**



**ROTATING DRIVELINE CONTACT CAN CAUSE DEATH KEEP AWAY!**

**DO NOT OPERATE WITHOUT :**

- All driveline guards, tractor, and equipment shields in place.
- Drivelines securely attached at both ends.
- Driveline guards that turn freely on driveline.

**⚠ DANGER**



**ROTATING BLADES KEEP HANDS AWAY**

**⚠ WARNING**

**To Prevent Serious Injury Or Death:**

- Read and understand Operator's manual before using.
- Do not permit riders on the tractor or mower. Never carry child on tractor seat.
- Operate with guards installed and in good condition.
- Operate only with tractor equipped with ROPS and seatbelts.
- Keep away from moving parts.
- Stop engine, set brake and wait for all moving parts to stop before dismantling.
- Be sure lights and reflectors required by law are clean and in good working order before transporting.
- Do not allow children to operate mower.
- Travel with SMV and lights that follow local codes.
- Clean debris from mowing area.
- Do not operate in the raised position.
- Support securely before working beneath unit.
- Review safety instructions annually.

**⚠ CAUTION**



**GREASE**

**⚠ WARNING**



**Read and understand operators manual before using this machine.**

## SAFETY

### GENERAL SAFETY RULES

Read this manual and labels affixed to the machine to understand its limitations and potential hazards.

Be thoroughly familiar with the controls and their proper operation.

If the unit is to be used by someone other than original purchaser or loaned, rented, or sold, always provide this manual and any needed safety training before operation. The user can prevent and is responsible for accidents or injuries that may occur to themselves, other people, and property.



Read and understand all instructions. Failure to follow all instructions listed below may result in electric shock, fire, and/or serious injury.



The warnings, cautions, and instructions discussed in this instruction manual cannot cover all possible conditions or situations that could occur. It must be understood by the operator that common sense and caution are factors which cannot be built into this product but must be supplied by the operator.

- All Federal and State laws and any regulation having jurisdiction covering the safety requirements for use of the machine take precedence over the statements in this manual. All users must comply with these regulations at all times.
- Only people that have read and understood these instructions are permitted to use the stump grinder.
- Inspect the stump grinder and tractor at the beginning of every working day and repair any defects.
- Stop the engine and make sure that the machine will not start accidentally while repairing defects or performing maintenance.
- Never disable or remove safety devices on the stump grinder.
- Always locate and mark buried wires, cables, and pipelines prior to grinding.

### PERSONAL SAFETY

Do not permit children to operate this machine at any time.

Keep children, pets, and other people not using the unit away from the work area. Be alert and shut off unit if anyone enters work area. Keep children under the watchful care of a responsible adult.

- Stay alert, watch what you are doing and use common sense when operating machinery. Do not use a machine when you are tired or under the influence of drugs, alcohol, or medication. A moment of inattention while operating machinery may result in serious personal injury.
- Dress properly. Do not wear loose clothing, dangling objects, or jewelry. Keep your hair, clothing, and gloves away from moving parts. Loose clothes, jewelry, or long hair can be caught in moving parts. Air vents often cover moving parts and should be avoided.
- Use safety apparel and equipment. Use safety goggles or safety glasses with side shields which comply with current national standards, or when needed, a face shield. Use a dust mask in dusty work conditions. This applies to all persons in the work area. Also use nonskid safety shoes, hardhat, gloves, dust collection systems, and hearing protection when appropriate.
- Do not overreach. Keep proper footing and balance at all times.
- Remove adjusting keys or wrenches before connecting to the power supply or turning on the machine. A wrench or key that is left attached to a rotating part of the machine may result in personal injury.
- Never conduct any maintenance or make any other adjustments while the tractor engine is running. Always shut the tractor engine off, remove the ignition key, and keep the engine off before carrying out any of the following procedures. Consult your tractor's operator manual for safe shutdown procedures to prevent accidental ignition.
- Never allow passengers to ride on the stump grinder.

Identify hazards and take preventive steps to avoid accidents and minimize risk. Possible hazards include, but are not limited to, moving parts, thrown objects, weight of the machine and components, and the operating environment.

Thoroughly inspect the area in which you are working, keeping it clean and free of debris to prevent tripping. Operate on a flat level ground.

Never place any part of your body where it would be in danger if movement should occur during assembly, installation, operation maintenance, repair, or moving.

Keep all bystanders and pets at least 75 feet away. If you are approached, stop the unit immediately.

## UNPACKING THE CONTAINER

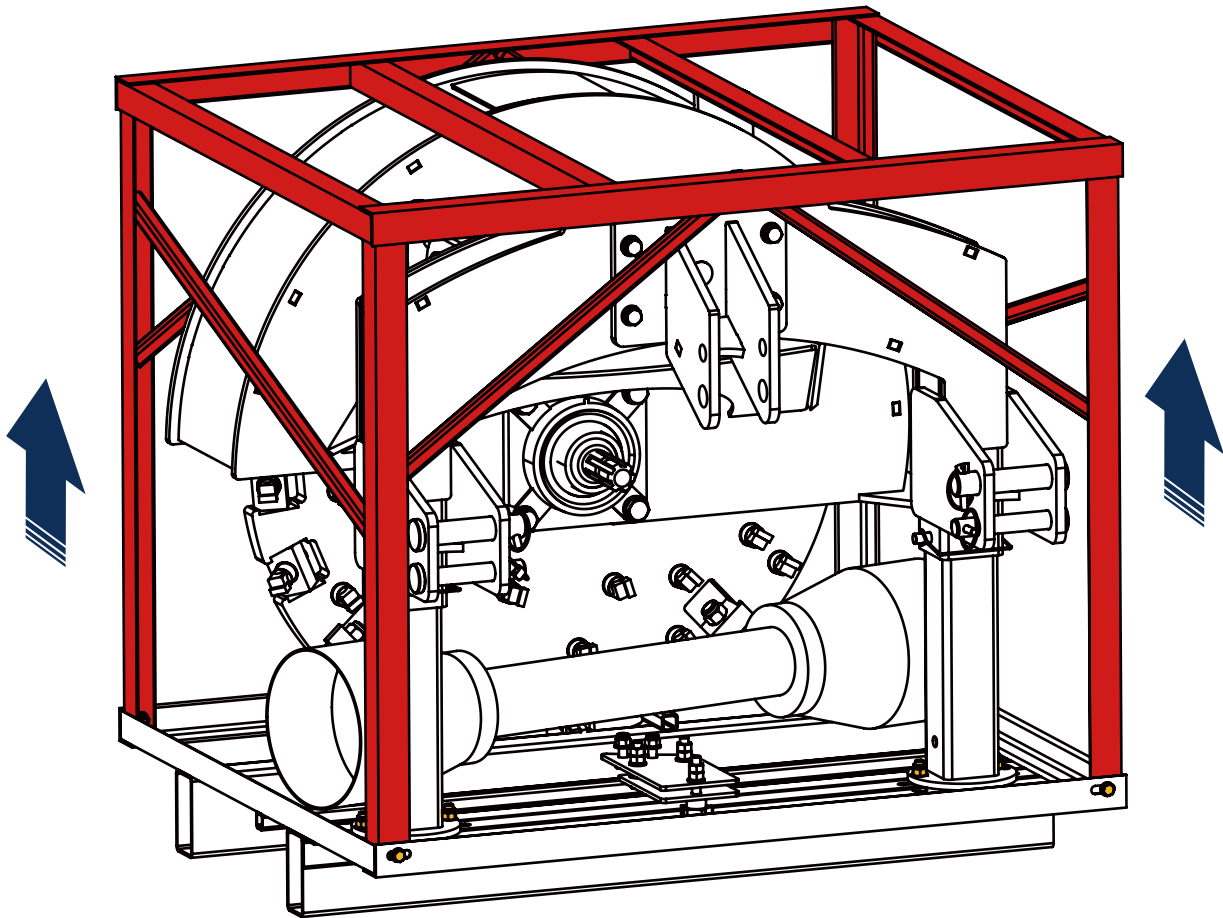

### TOP FRAME

Unfasten the M8 X 20 mm hex bolts from the four (4) bottom corners of the crate and remove the top frame.

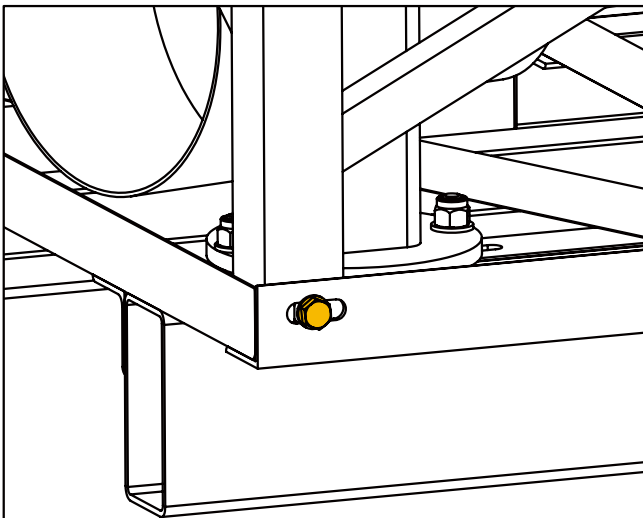

### SUPPORT LEG

Unfasten the two (2) M10 x 25 mm hex bolts securing both support legs to the bottom crate frame.

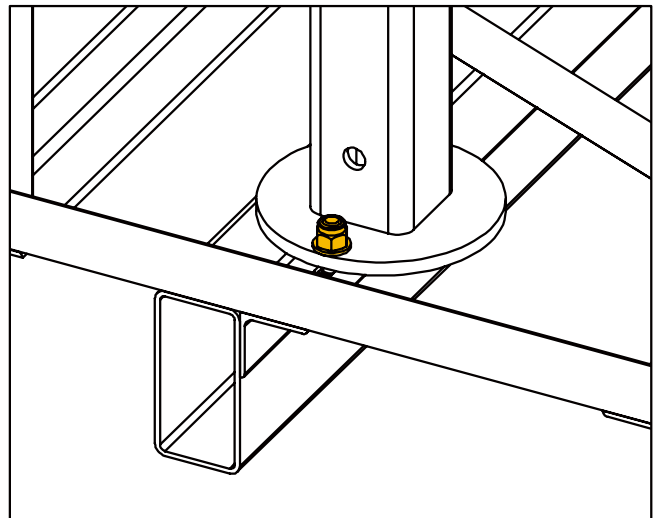

## CONTENTS SUPPLIED

Your PTO Stump Grinder comes partially assembled and contains the following:

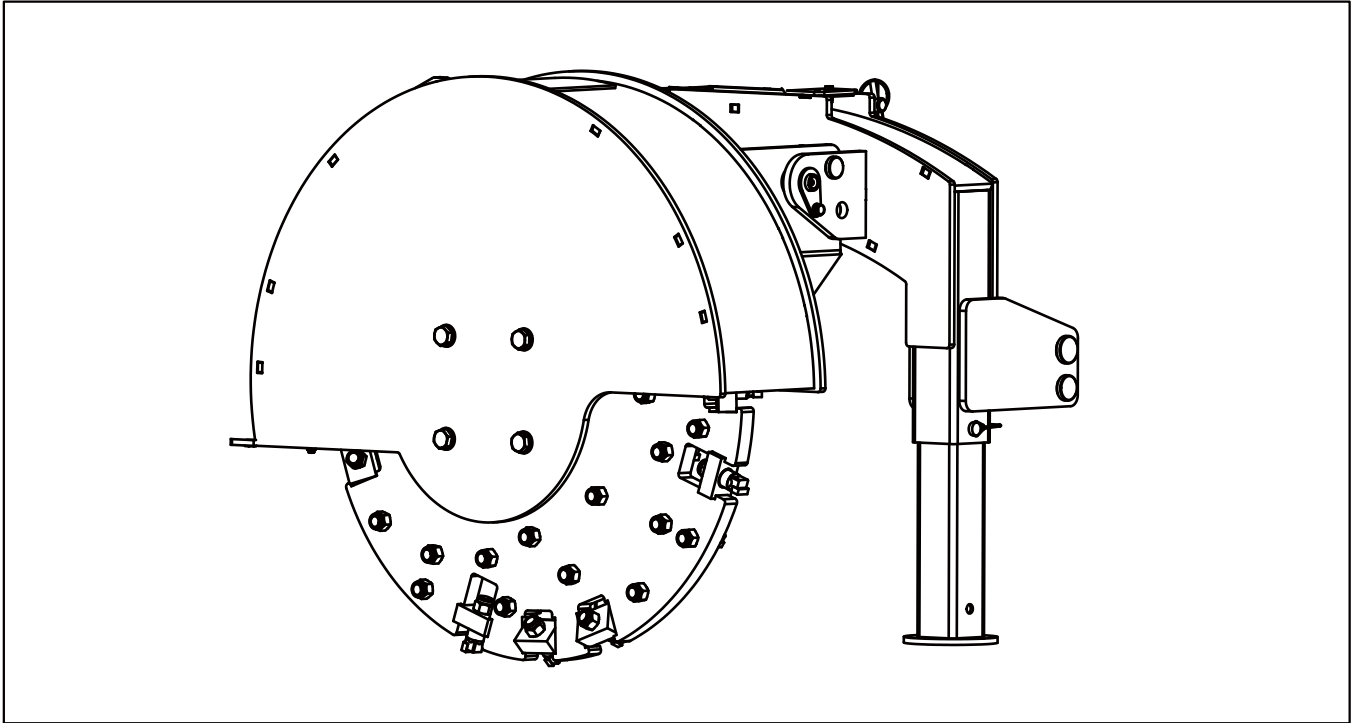

1x

SG30 PTO STUMP GRINDER

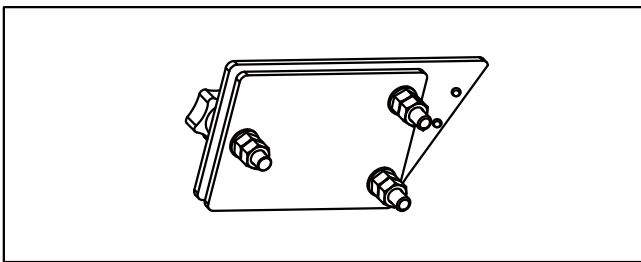

1x

Chainsaw Holder Assembly

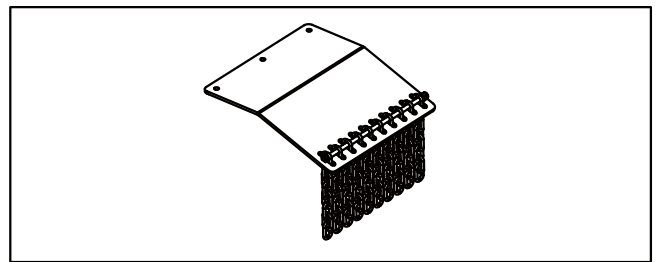

1x

Deflector Plate

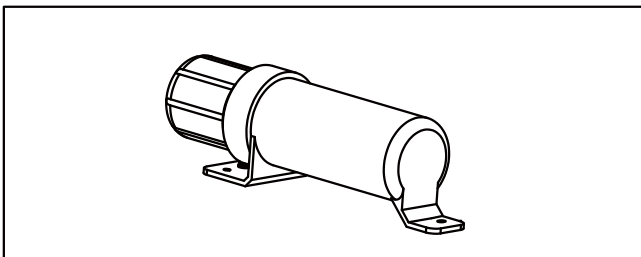

1x

Manual Tube

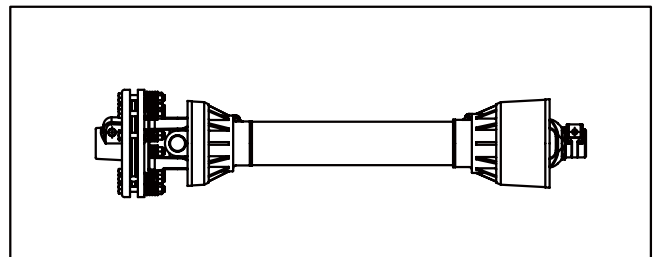



1x



PTO Shaft

Verify all component and hardware quantities are correct prior to assembling the stump grinder.

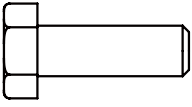
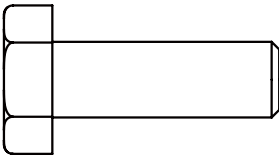
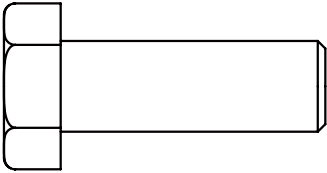
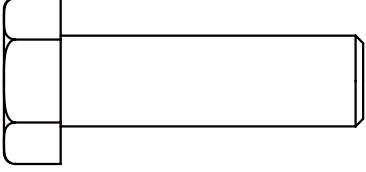
**TO-SCALE HARDWARE**

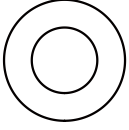
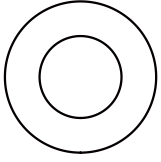
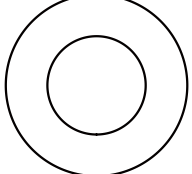
Hardware graphics are printed at 1:1 scale for ease of identification. Simply place the hardware over the image in the tables to verify it is the correct size.

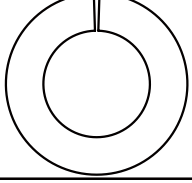
Hex bolt M6 X 20mm 2X	
Hex bolt M8 X 30mm 3X	
Hex bolt M10 X 50mm 2X	
Hex bolt M12 X 40mm 4X	
Flat washer 6 6X	
Flat washer 8 6X	
Flat washer 10 2X	
Flat washer 12 4X	

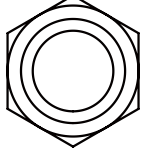
Spring washer 12 4X	
Hex lock nut M6 2X	
Hex lock nut M8 3X	
Hex lock nut M10 2X	

## ASSEMBLY

### TOP LINK BRACKET

Loosen the nut on the front side of the back frame just enough so the top link bracket can be rotated 180° for the next assembly step.

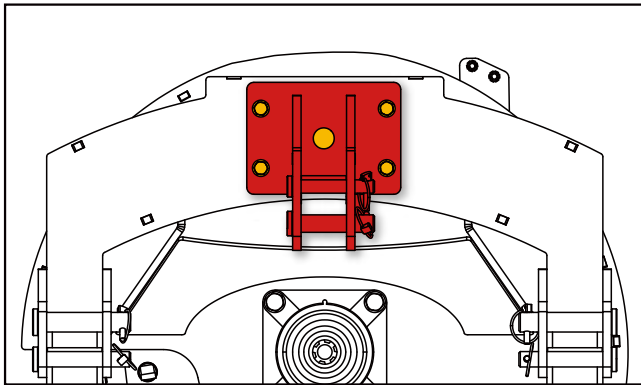

Hex lock nut M10



Orient the top link bracket so that it is rotated 180° from how it was shipped in the previous step. The hitch pin must be on top. Secure it to the back frame using four (4) M12 X 40 mm hexbolts, M12 flat washers, and Spring washer 12.

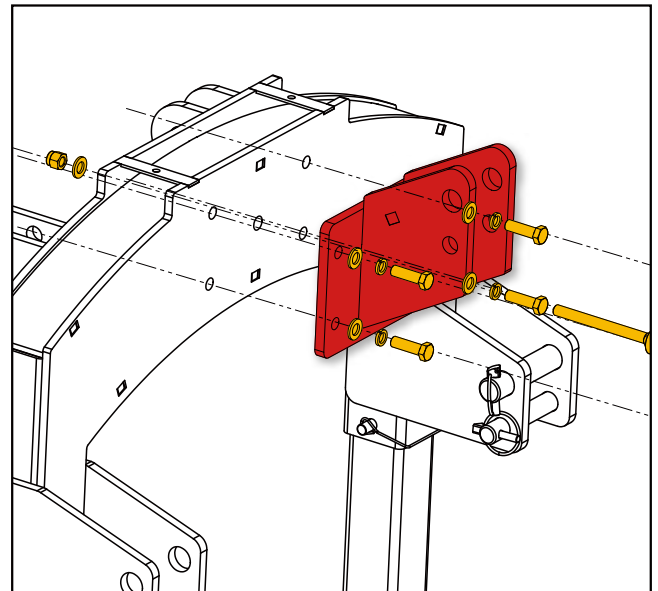
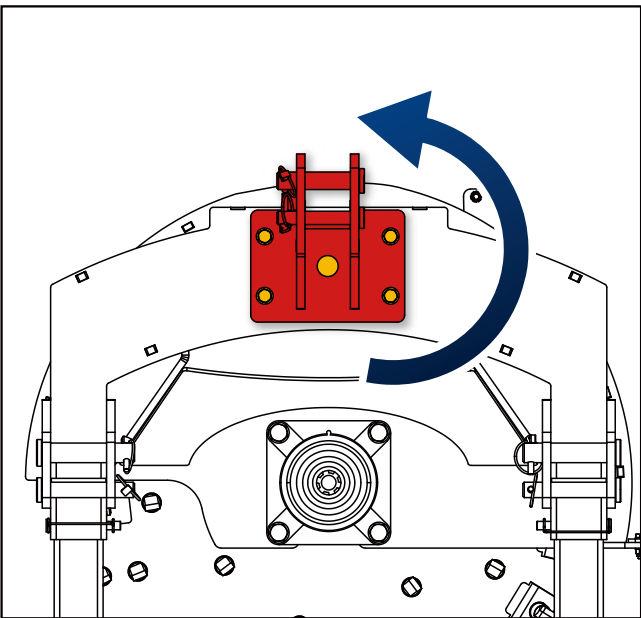

4X Hex bolt M12 X 40mm



4X Flat washer 12



4X Spring washer 12



### DEFLECTOR

Using the hardware listed below, assemble the deflector to the flywheel housing as shown.

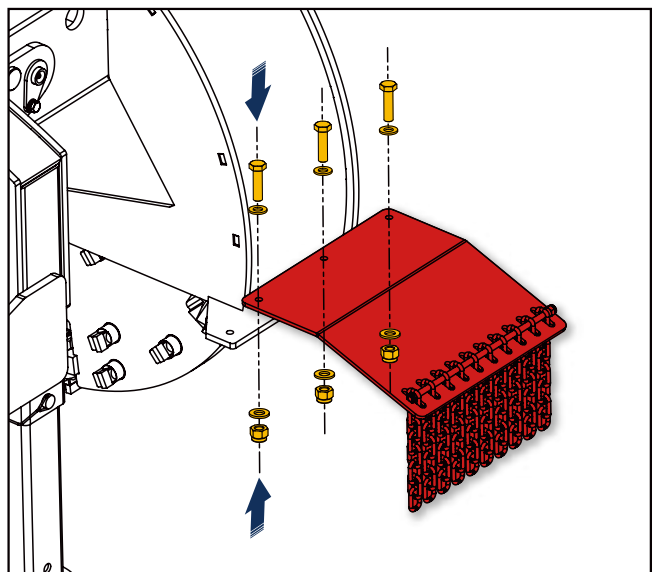

3X Hex lock nut M8



3X Hex bolt M8 X 30mm



6X Flat washer 8



## CHAINSAW HOLDER

Using the hardware listed below, assemble the chainsaw holder to the flywheel housing as shown.

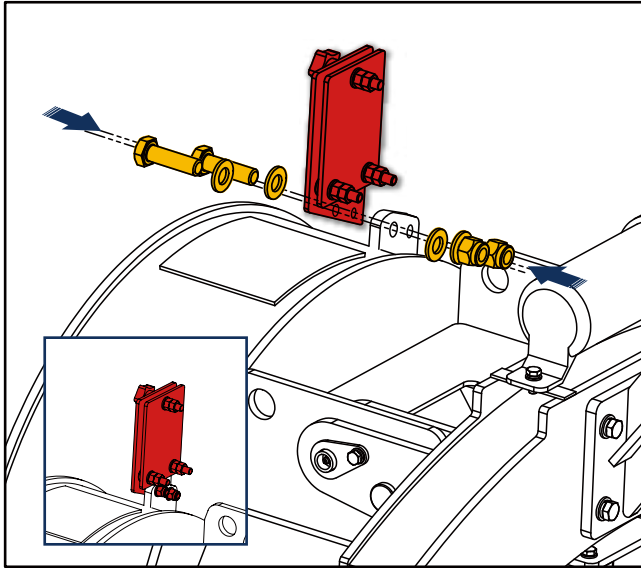

2X Hex lock nut M10



2X Hex bolt M10 X 50mm



2X Flat washer 10



## MANUAL TUBE

Using the hardware listed below, assemble the manual tube to the back frame as shown. Remove the cap from the manual tube to gain access to the centre mounting hole.

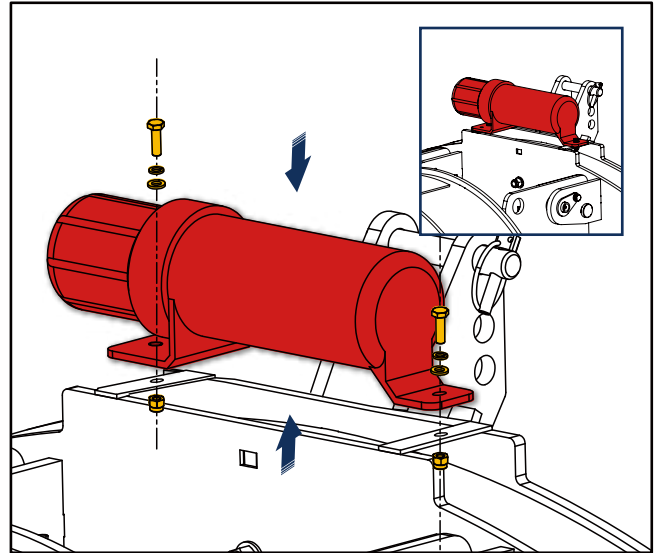

2X Hex lock nut M6



2X Hex bolt M6 X 20mm



2X Flat washer 6



## KNOW YOUR MACHINE

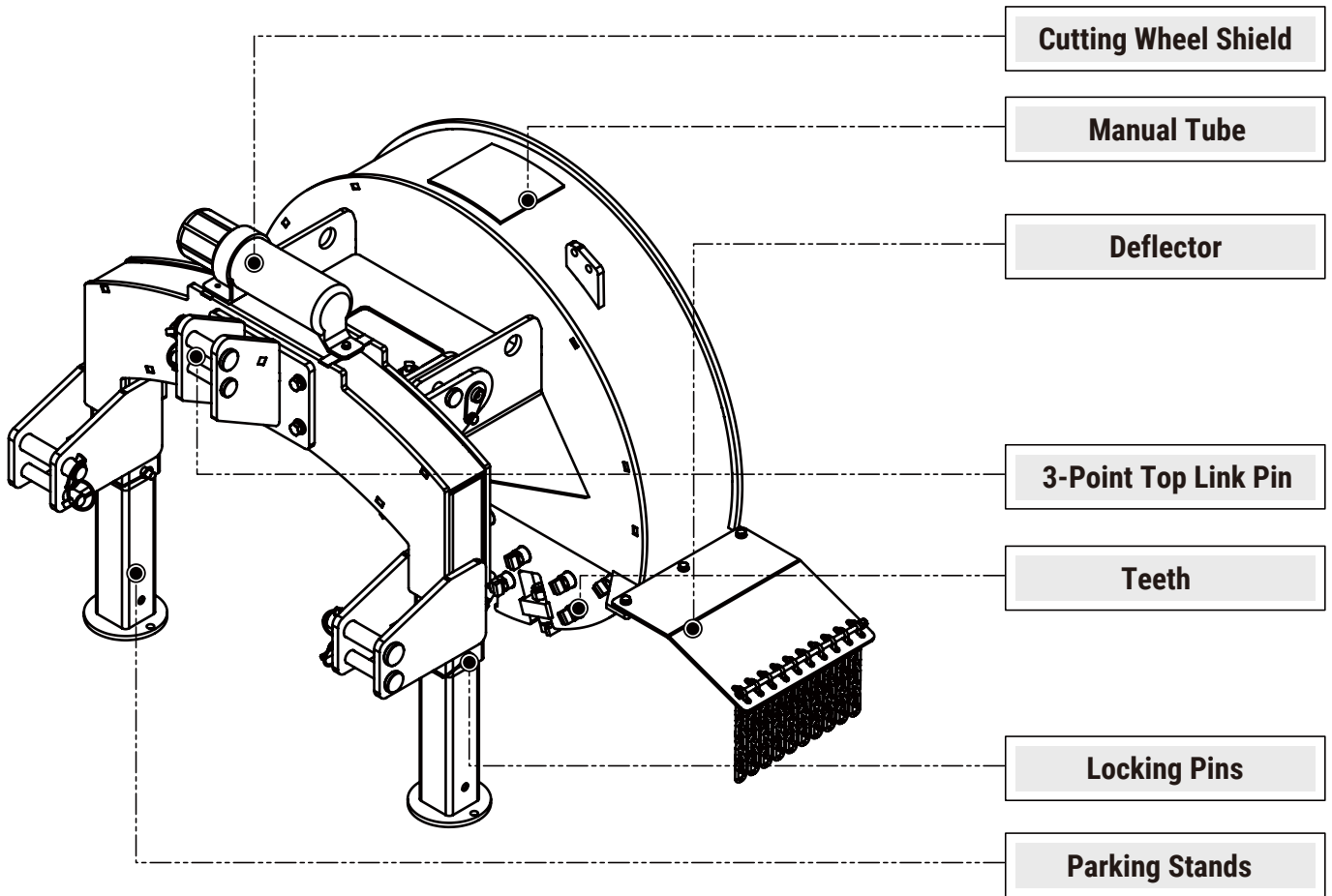

## SET-UP PROCEDURES

### TRIMMING THE PTO SHAFT

The stump grinder is shipped with a slip clutch PTO shaft that can be fitted to most Category 1 tractors. The PTO shaft may need to be trimmed depending on your tractor and configuration. Follow the steps below to ensure the PTO shaft is correctly fitted to your tractor.

**Note:** the slip clutch end of the PTO shaft mounts to the stump grinder.

- Attach the stump grinder to the tractor's 3-point hitch system. Do not install the PTO shaft.
- Raise the stump grinder so that the shaft on the tractor is in line with the shaft on the stump grinder.
- Measure the distance between the locking grooves on the splined shafts of the tractor and stump grinder (Dim A) as shown below:

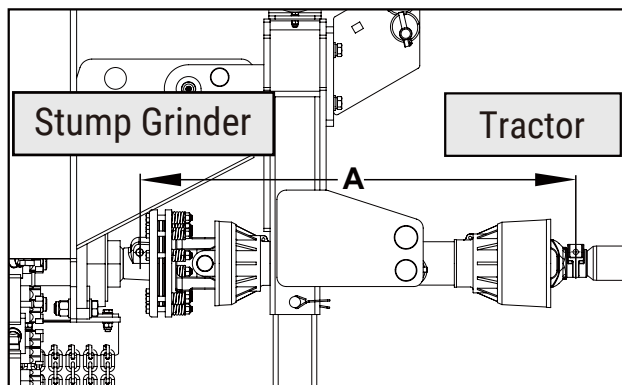

### Determine Driveshaft Length

Verify the distance between the locking pins on the PTO shaft while in the compressed state (Dim B) as shown in the image below. It should measure 34" (862.5 mm).

If Dimension A is at least 1 inch (25 mm) longer than Dimension B, the PTO shaft does not require trimming. It is recommended the shaft not be used if there is less than 6" (150 mm) of overlap between the two halves of the PTO shaft when the equipment is in the operating position.

If Dim B is longer than Dim A, the PTO shaft will require trimming. Use this equation to calculate the correct amount to trim:

$$(B - A) + 1 \text{ inch} = C \text{ (Amount to Trim)}$$

Once C has been calculated, trim that amount from BOTH halves of the PTO shaft safety cover first, then trim the same amount from both shafts. This will ensure the safety cover on each end remains a few inches back from the ends of the shafts, otherwise PTO shaft reassembly could be difficult.

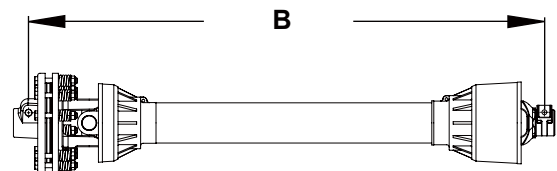

After trimming both halves of the PTO shaft, use a file to remove any burrs or sharp edges and slide the halves back together, ensuring they telescope in-and-out freely. The PTO shaft is now ready to connect the stump grinder to the tractor for operation.

## PTO SHAFT CLUTCH RUN-IN

The stump grinder is shipped with a slip clutch PTO shaft. Follow the steps below before using your stump grinder to ensure the PTO shaft clutch plates are set properly.

**\*\*This procedure should be performed periodically during ownership as the clutch plates can stick together, particularly after long periods of inactivity. This can prevent the plates from slipping during operation as designed, resulting in high loads and possible damage to the steel shaft, which is not covered under warranty.\*\***



Entanglement in a rotating driveshaft can cause serious injury or death. Disconnect and lockout power source before adjusting or servicing.

- Connect the PTO shaft to the stump grinder and tractor with the clutch end of the PTO shaft mounted to the stump grinder. Insert the locking pin on the clutch yoke and tighten the nut using a wrench/socket.
- Using a coloured pencil or marker, scribe a line across the exposed edges of the clutch plates.
- Using a wrench/socket, loosen all 8 spring tension nuts uniformly until the ends of the nuts are flush with the ends of the bolts .

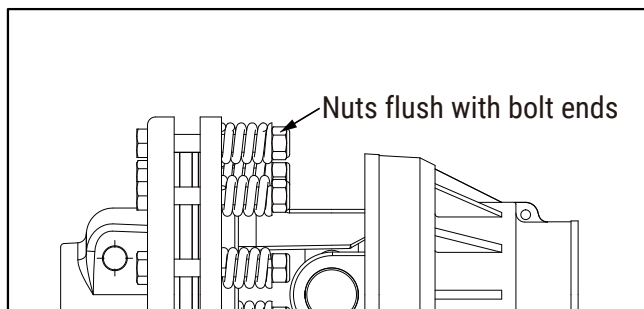
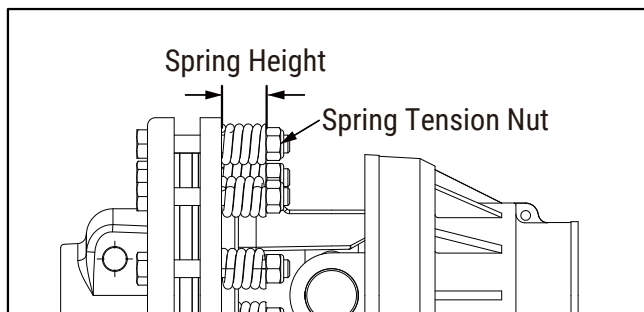

- Tighten all 8 nuts until the proper spring height dimension values are achieved per the "PTO Shaft Clutch Spring Height vs. Horsepower" table for your PTO output horsepower. It is recommended that a calliper (either digital, dial, or vernier-similar to the one shown below) be used to accurately verify the spring height measurements. After setting all 8 spring heights, the clutch is now ready for use.

### PTO Shaft Clutch Spring Height vs. Horsepower

Clutch Flange Dia	PTO hp	Spring Height
7-5/8" (200 mm)	40-100 HP	1.16 in [29.5 mm]

All ratings are at 540 rpm PTO speed

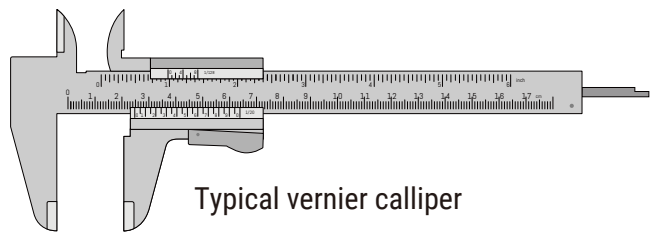

Typical vernier calliper

- The clutch should be checked during the first hour of use and periodically each week thereafter. Excessive clutch plate slippage, burning odour, or visible smoking should not be observed during use.
- Start the tractor and engage the PTO for 2-3 seconds to permit slippage of clutch surfaces. Disengage the PTO then re-engage a second time for 2-3 seconds. Disengage the PTO again, shut off the tractor, and remove the key. Wait for all components to stop rotating before removing the PTO shaft from tractor.
- Inspect the clutch and ensure that the scribed markings made across the clutch plates have changed position. Slippage has not occurred if the two marks on the clutch plates are still aligned. A clutch that has not slipped must be disassembled to separate the clutch plates.

## FLYWHEEL TOOTH TORQUING

Prior to each operation, be sure to tighten all 44 teeth using a ring spanner with a 24 mm socket.

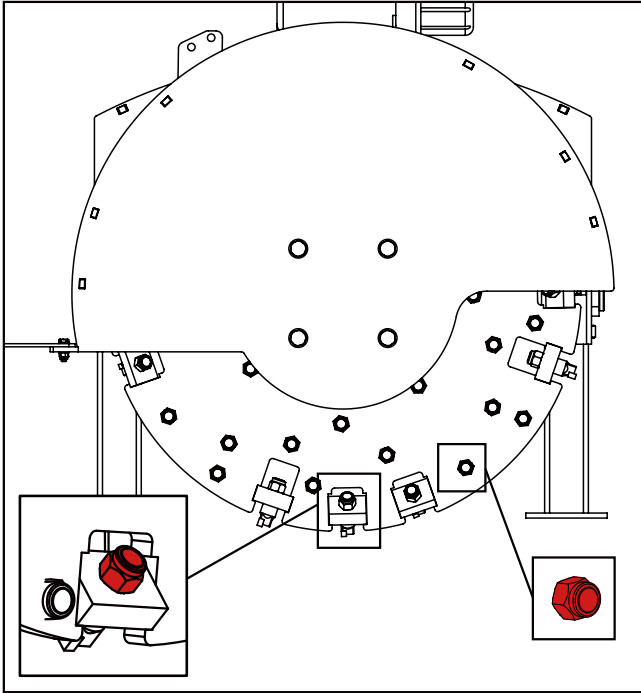

### TORQUE ADAPTER

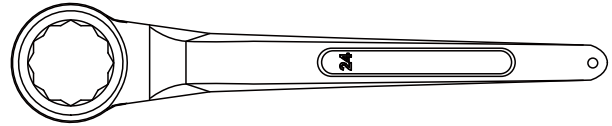

Slide the ring spanner over the nut and torque the nut by rotating it clockwise. Repeat the process for all four (4) of the outward-pointing teeth.

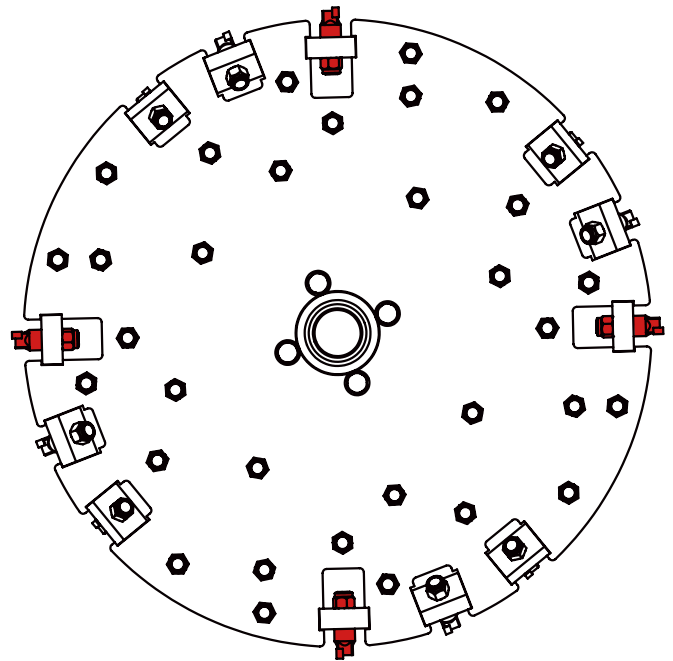

---

## OPERATION

---

### PRE-START CHECKLIST

Check these items:	Frequency
Check the three lynch pins on the hitch to verify they are securely fastened.	Each operation.
Verify the pins on each end of the drive shaft are secured.	Each operation.
Verify the safety chains on the drive shaft are securely attached to the cover.	Each operation.
Grease pivot pins	Each operation.
Verify the cutting tips on the cutting wheel are tight.	Every 4 hours.

## STARTUP

### PREPARATION FOR USE



The warnings, cautions, and instructions discussed in this instruction manual cannot cover all possible conditions or situations that could occur. It must be understood by the operator that common sense and caution are factors which cannot be built into this product but must be supplied by the operator.



Wear an approved dust mask or respirator. Follow local, state and federal regulations.

Although the stump grinder has been carefully inspected and checked prior to shipment from manufacturer, it is recommended that the unit be thoroughly inspected. Check all bolts for tightness and remove all shipping tags, bags, skids, and blocking. Remove any masking materials affixed during painting. Inspect the tractor and any accessory equipment to verify that nameplates and all safety warning, caution signs and decals provided with the equipment are in place and clearly visible. Verify the three lynch pins are securely fastened. Visually inspect the unit before each start up. Check for loose or missing parts and any damage that may have occurred during moving or shipping.

Review all tractor pre-start instructions, and ensure that all recommended steps and procedures have been followed. Never bar over the rotor, This could cause damage and result in personal injury or equipment damage. Note: Always keep the weight of the machine in mind. Never place your body in the potential line of impact.

### ATTACH STUMP GRINDER TO TRACTOR

To prevent injury or machine damage put transmission in "Park" and check the full range of hitch for interference, binding or PTO separation. Never position yourself between tractor and stump grinder. Only experienced and properly trained operator's should operate the tractor and stump grinder.

Note: Tractors must have hydro-static drive. Read all safety instructions.

- Check for loose teeth or any other loose parts.
- Verify there is sufficient visibility and maneuverability to move up to stump grinder.
- Remove the stabilizer pin prior to operation as shown below:

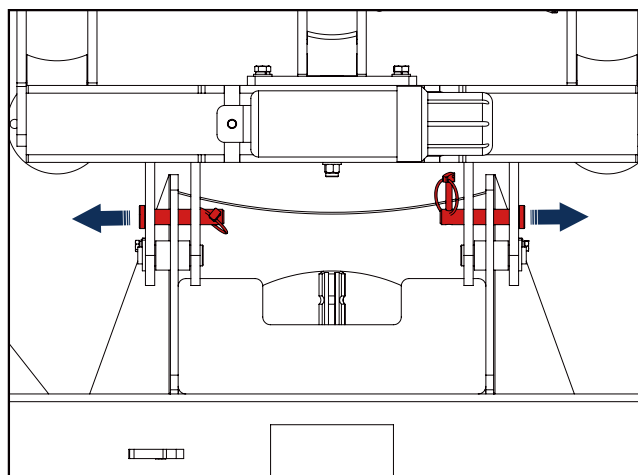

- Remove the leg locking pins, slide the legs up inside the tubes, and reinstall the locking pins to secure them in place.

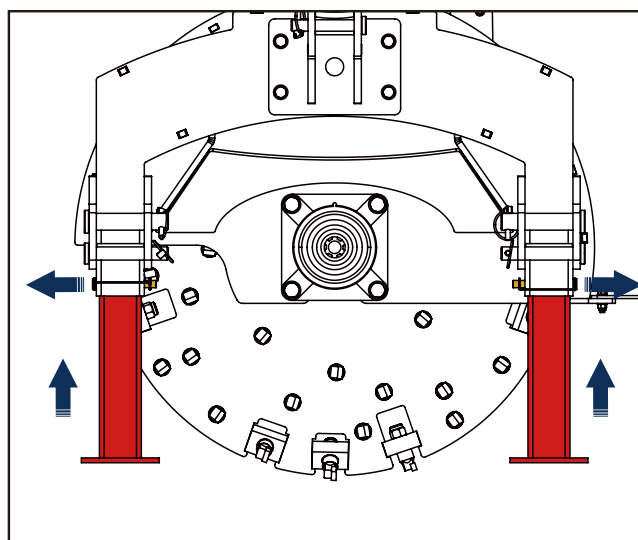

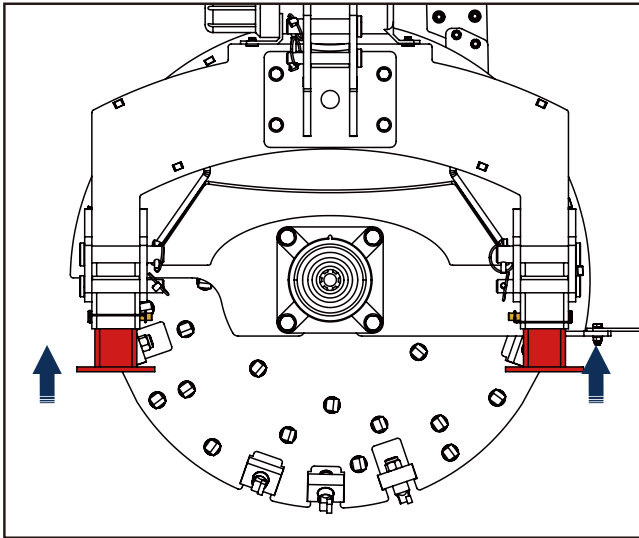

- Reverse over a tree stump and lower the stump grinder so it will remove 2" (50 mm) perpass. Always ensure the grinder is cutting properly and not jumping around erratically
- Once the stump is at ground level, continue to take up to 2" (50 mm) deep passes until the stump and roots are 4-6" (100-150 mm) below grade. Keep a watch out for foreign objects below the soil like rocks or buried metal. These can damage or break the teeth resulting in poor grinding performance.
- During use, it is important to never let the stump grinder sway beyond an angle that will allow the PTO shaft to separate. Do not operate the stump grinder with less than 6" (150 mm) of overlap between the two halves of the PTO shaft. If the stump grinder begins to sway, it means either the tractor is advancing faster than the grinder can remove material or that too much material is being removed per pass. If this is observed, immediately stop moving forward and position the tractor and stump grinder in a manner so that it is in the vertical position. Take a slower pass and/or shallower cut if necessary.
- Attach tractor to stump grinder. See tractor Operator's Manual.

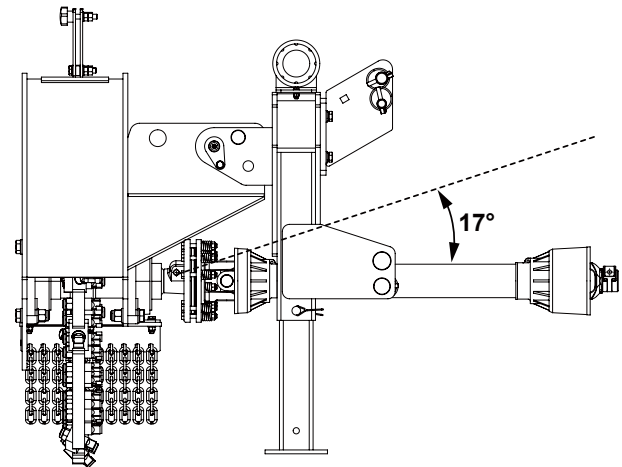

- Adjusting top link so that the driveshaft is straight in the raised position will ensure that the driveshaft angle is acceptable (17° or less) when the rotor is swung back in the extreme cutting position.

### FIRST TIME USER TIPS

Before you begin, make sure the tractor is turned off and the PTO drive is disengaged.

Stand to the side of the stump grinder and observe the center point on the bottom of the cutting wheel. Now sit on the tractor seat and observe the center point again. This point will appear different depending on where you are positioned. This can be very deceiving! Familiarize yourself with the view of the stump grinder from the tractor seat.

Test all operating functions in an open area with the tractor at idle speed to get a feel for the controls. Take your time.

Start with a small stump. Make the first pass then disengage the PTO drive and get off the tractor to see how much you have removed.

Get off the tractor after each pass to check the progress. The cutting wheel is shielded from view when sitting on the tractor seat so it is difficult to accurately determine the progress. The ability to judge the positioning improves with practice. Do not expect to get the first stump done quickly.

 Prevent equipment damage. Operation with pto shaft at a severe angle (over 17°) may result in equipment damage. Adjust top link pto shaft is as straight as possible.

 Always turn off the tractor and disengage the PTO drive before getting off the seat and approaching the cutting wheel.

## Field Operation



Entanglement in a rotating driveshaft can cause serious injury or death. Keep tractor shields and driveshaft shields in place at all times. DO NOT operate without driveshaft guards. DO NOT wear loose fitting clothing.



Prevent serious injury or death caused by unexpected movement:

1. Park tractor on a level surface.
2. Engage tractor park brake.
3. Disengage PTO.
4. Shut off engine and remove key.



Never operate stump grinder when other people are in the vicinity. Debris can be thrown several feet from cutting area. Keep all shields in place.



Never operate tractor when other people are in the vicinity. Do not allow riders on tractor.



Drilling, sawing, sanding or machining wood products can expose you to wood dust, a substance known to the State of California to cause cancer. Avoid inhaling wood dust or use a dust mask or other safeguards for personal protection.



Wear an approved dust mask or respirator. Follow local, state and federal regulations.

Attach stump grinder to tractor. See Attaching Stump Grinder to Tractor in this section.

Note: All cutting is done on the front side of the cutting wheel, not the bottom of the wheel.

If the stump is on a grade, position tractor lower on the grade with the cutting wheel on the stump grinder higher up the grade.

Below is an approximate cutting time for the stump shown in the image on the next page.

20 Hp tractor - 30 minutes

30 Hp tractor - 20 minutes

40 Hp tractor - 15 minutes

Operation should be smooth and grinding should be done gradually. If the stump grinder is jumping or bouncing off the stump, you are applying too much force. Applying too much force will shorten the life of the cutting teeth and may damage the stump grinder.

## STUMP GRINDING PROCEDURE

Observe all operating and safety instructions in this manual and those on the Stump Grinder before using this machine.

Position the tractor for grinding a stump. The 3 pt. frame should be lowered to the ground before grinding the stump. Three point hitch lift arm stabilizer bars, sway chains or sway blocks must be used to control side movement of the stump grinder.

**NOTE:** Be sure parking stand is fully raised and fastened with a locking pin before using the stump grinder.

Set the tractor brakes or place the transmission in "PARK." Raise the cutting wheel and have it positioned to the left side of the stump and all the way to the left side of the machine.

Right-hand or left-hand reference is determined by standing at the rear of the stump grinder and facing in the forward direction of travel of the power unit.

When engaging and disengaging the PTO, the engine speed should always be low. Once the PTO is engaged and ready to start cutting, raise the PTO speed to 540 RPM and maintain throughout stump cutting operation. ALWAYS operate the PTO at 540 RPM. This is necessary to maintain proper wheel speed to obtain a clean, smooth cut. Do not disengage PTO when the engine is at full PTO RPM. Always bring the tractor engine to idle speed before disengaging the PTO.

**NOTE:** To avoid damage to the clutch, the cutter wheel should not be in contact with the stump when engaging the PTO.

Start the wheel on the edge of the stump and engage the side hydraulic cylinder to make a light cut across the stump.

When the first cutting pass is complete, raise the cutting wheel slightly with the depth control cylinder and then activate the side control cylinder to move the wheel back to the start position.

The flywheel spins clockwise (when facing the rear of the machine) with the effective cutting area in the lower-left quadrant as shown below:

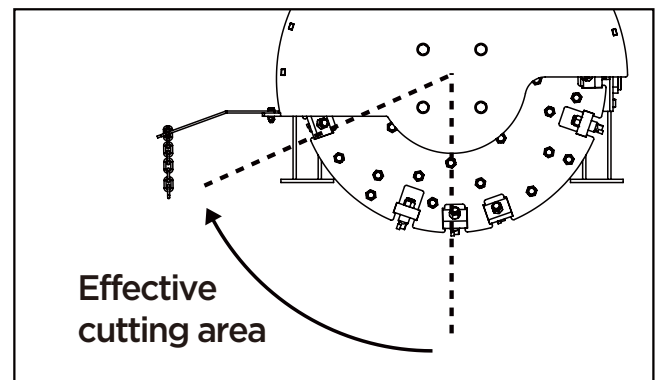

When grinding a tree stump always start from the right side of the stump, moving incrementally to the left, pulling the grinder straight forward through the stump on each pass. When grinding softwoods like pine, spruce, or poplar, it may be permissible to remove upwards of 2" (50 mm) of material per pass. However, hardwoods like oak, ash, and birch can be much more dense and the depth of grind may only be up to 1" (25 mm). If the chassis is swaying like described in the previous section, or the grinder is vibrating or bouncing, reduce the depth of cut or feed rate accordingly.



Before moving the machine into position, remove loose chunks of wood, stones, wire, and other debris from the stump and work area that might be thrown, causing injury or damage.



When cutting a stump, the operator must wear eye protection and must stay on the power unit seat.

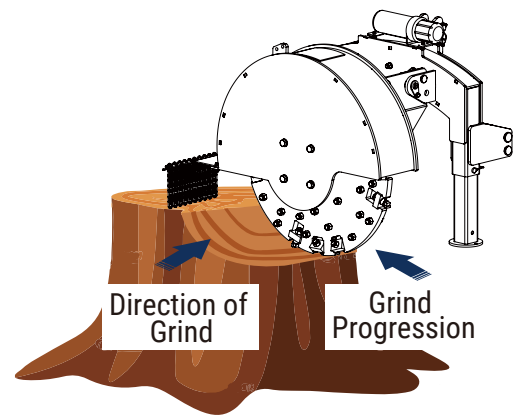
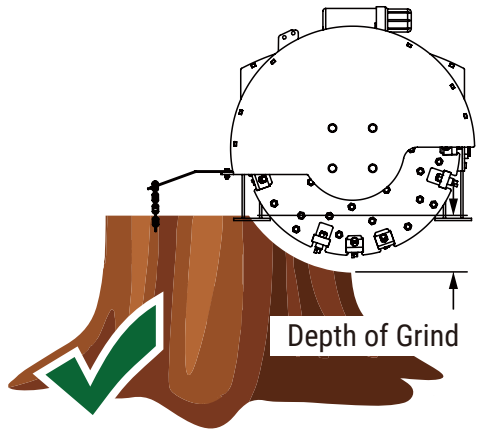

## INCORRECT GRINDING PROCEDURES

It is critical that the stump grinder is never pulled through the centre of a stump or ground from left-to-right. This will induce severe vibration and cause the grinder to sway and bounce. It may also damage the machine and/or break teeth.

### PULLING THROUGH THE CENTRE

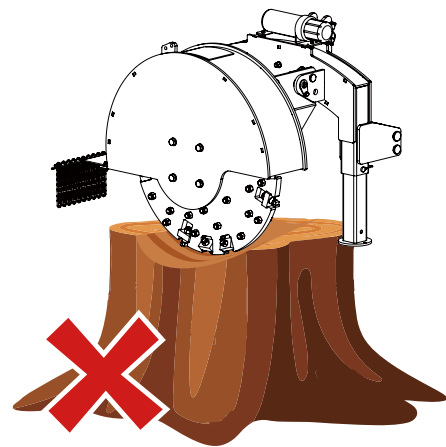
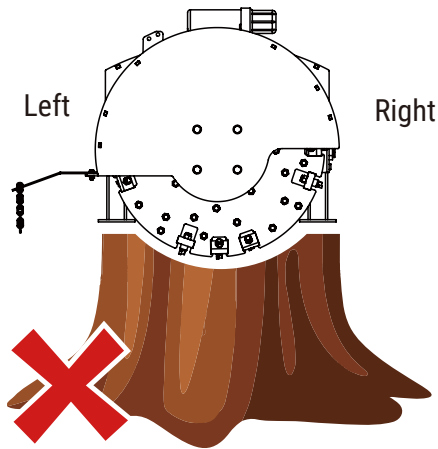

### GRINDING LEFT-TO-RIGHT

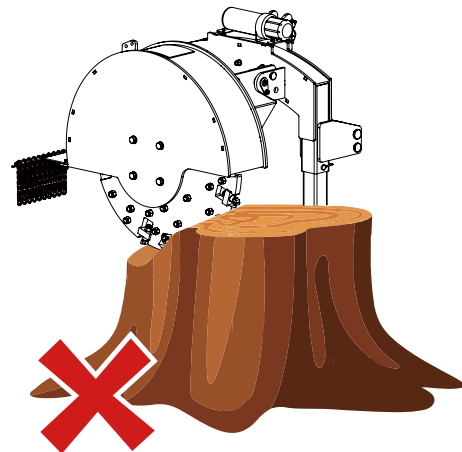
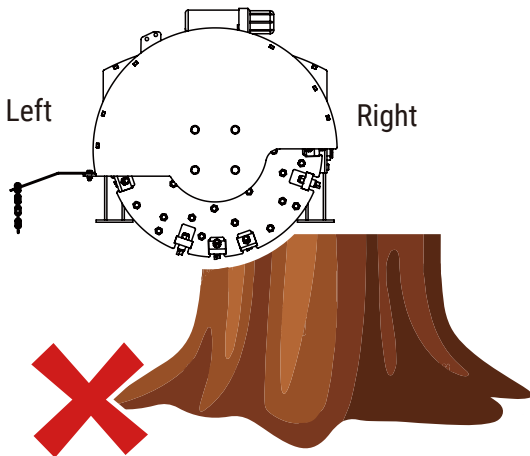

---

## MACHINE USE AND CARE

---

Always be sure the operator is familiar with proper safety precautions and operation techniques before using machine.

Do not force the machine. Machines do a better and safer job when used in the manner for which they are designed.

Storing the machine. When the machine is not in use, store it in a dry, secure place or keep it well-covered and out of the reach of children. Inspect the machine for good working condition prior to storage and before each use.

Maintain the machine. It is recommended that the general condition of the machine be examined before it is used. Keep your machine in good working order by adopting a program of conscientious repair and maintenance in accordance with the recommended procedures found in this manual. If any abnormal vibrations or noise occurs, turn the machine off immediately and have the problem corrected before further use.

Cleaning. Use a pressure washer to clean the carbide teeth while taking care not to pressure-wash the bearings as this could introduce water into areas of the machine that may cause malfunction or damage.

Use only accessories that are recommended by the manufacturer. Accessories that may be suitable for another machine may create a risk of injury when used on this machine.

Always operate the machine with all safety devices and guards in place and in good working order. DO NOT modify or make changes to safety devices. DO NOT operate the machine if any safety devices or guards are missing or inoperative.

Never leave the machine running unattended.

Never use the machine to grind anything other than stumps or for any purpose other than grinding stumps as described in this manual.

## MAINTENANCE

Proper routine maintenance is critical to operator safety, achieving proper stump grinding results, and prolonging the life of the machine.

Before cleaning and/or any maintenance is performed on the stump grinder, always turn off the tractor engine and disconnect the PTO shaft.

Inspect the machine before each use for loose nuts and worn cutting teeth and clean any debris that has built-up. After 2 hours of operation, check for loose nuts and worn cutting teeth. Tighten and replace as necessary.

Grease the bearings and the pivot pins on the main housing as needed before each use. Do not over-grease the bearings as this can blow out the seals and cause premature bearing failure. Refer to section, GREASING, for information.

Inspect the clutch plates on the PTO shaft periodically to ensure that they are not seized together. Refer to PTO SHAFT CLUTCH RUN-IN in the SET UP PROCEDURES section of the manual.

### REPLACING TEETH

Disconnect the PTO shaft from the tractor and set the stump grinder on a flat, level surface.

Remove the M16 X 1.5 lock nut (fine thread) from the back of the tooth using a 24 mm wrench or socket.

Remove the worn cutting tooth while noting its orientation so that the replacement tooth will be installed in the same manner.

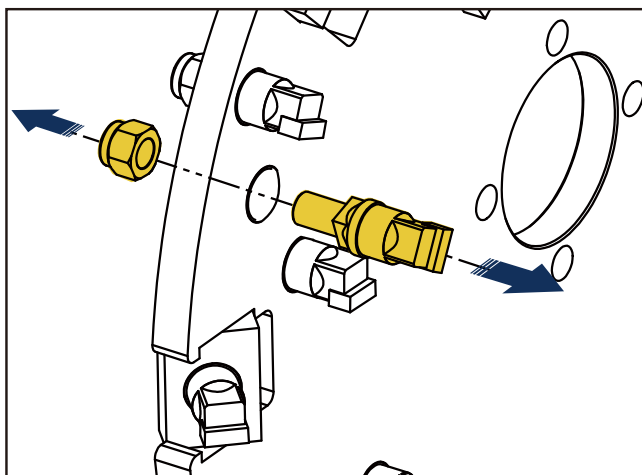

Install the replacement tooth and lock nut using a torque wrench set to 160 ft-lb (215 N-m).

### GREASING

The stump grinder has six (6) grease points: two (2) flywheel bearings, two (2) hinge pins, and two (2) on the PTO shaft. Check each grease point prior to use and add grease as needed.

**\*\*Warning:** These grease points come pre-greased from the factory. Do not add grease to these points on a new stump grinder. Over-greasing can damage the bearing seals.\*\*

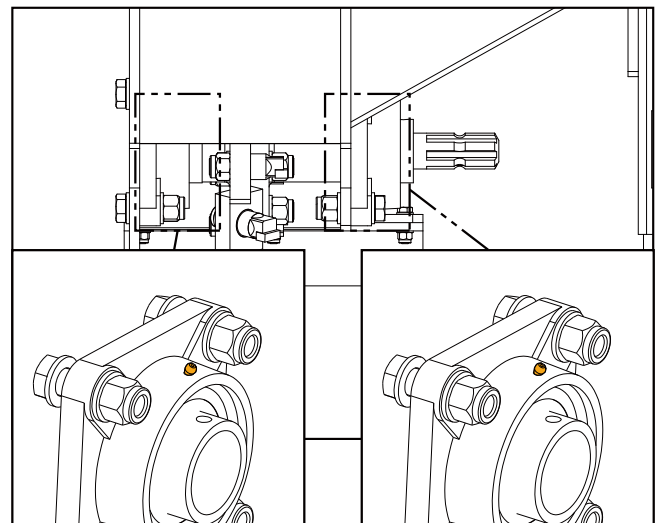

Flywheel Shaft Bearings (Underside of Flywheel Housing)

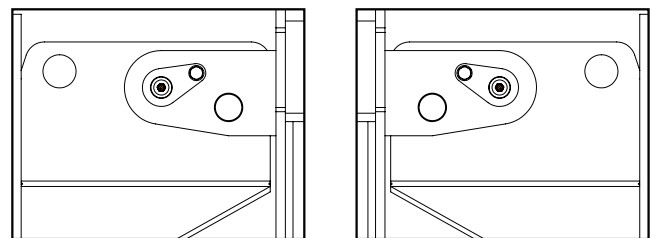

Right Pivot Hinge

Left Pivot Hinge

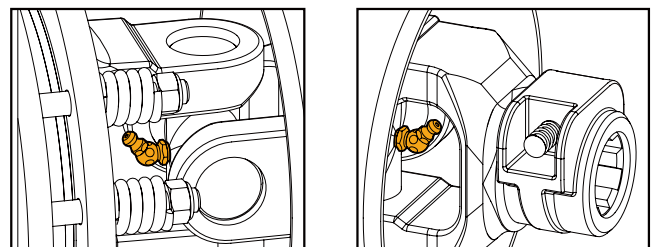

PTO Shaft: Slip Clutch End

PTO Shaft: Tractor End

## TROUBLESHOOTING

PROBLEM	CHECK	SOLUTION
Cutting wheel does not spin.	Cutting wheel jammed.	Remove material from cutting wheel.
	Slip clutch is slipping.	Remove jam from cutting wheel.
	Rotor stub shaft broken.	Check that driveshaft angle is not too severe (17° or less). Replace stub shaft.
Tractor is not able to lift 3-point.	Tractor is too small.	Move link pins to the top position on the stump grinder to add leverage.
Cutting wheel cannot be lifted high enough.	Stump too tall.	Cut stump shorter. Shorten top link on 3-point hitch.
Cutting wheel cannot be lowered far enough.	Top link not correct length.	Lengthen top link on 3-point hitch.
Cutting wheel does not have much power.	Tractor too small.	Verify tractor is properly sized for grinder.
	Slip clutch is slipping.	Check to determine if the slip clutch is hot. Use Caution: This Can Be Very Hot! A hot clutch does NOT grip. Slippage on the clutch occurs if there is more power than the unit is rated for. A bigger tractor can be used if it is idled down as this will decrease the output power of the engine. Take smaller passes (less cutting) to decrease the strain on the clutch. Turn the flow control knob to a lower number to reduce the strain on the slip clutch.

---

## STORAGE

---

### STORING GRINDER

- Store grinder in a dry place.
- Clean grinder thoroughly. Dirt and wood chips will draw moisture and cause rust.
- Lubricate machine. (See Service and Maintenance section.) if necessary. (See Service and Maintenance section.)
- Check condition of cutting teeth. Replace as
- Check for loose or missing hardware.
- Paint parts as necessary.
- Store PTO driveshaft off the ground.

### REMOVE FROM STORAGE

- Review Operator's manual and check adjustments.
- Lubricate machine. (See Service and Maintenance section.)
- If parts have been replaced, verify they run properly.

**PARTS DIAGRAM**

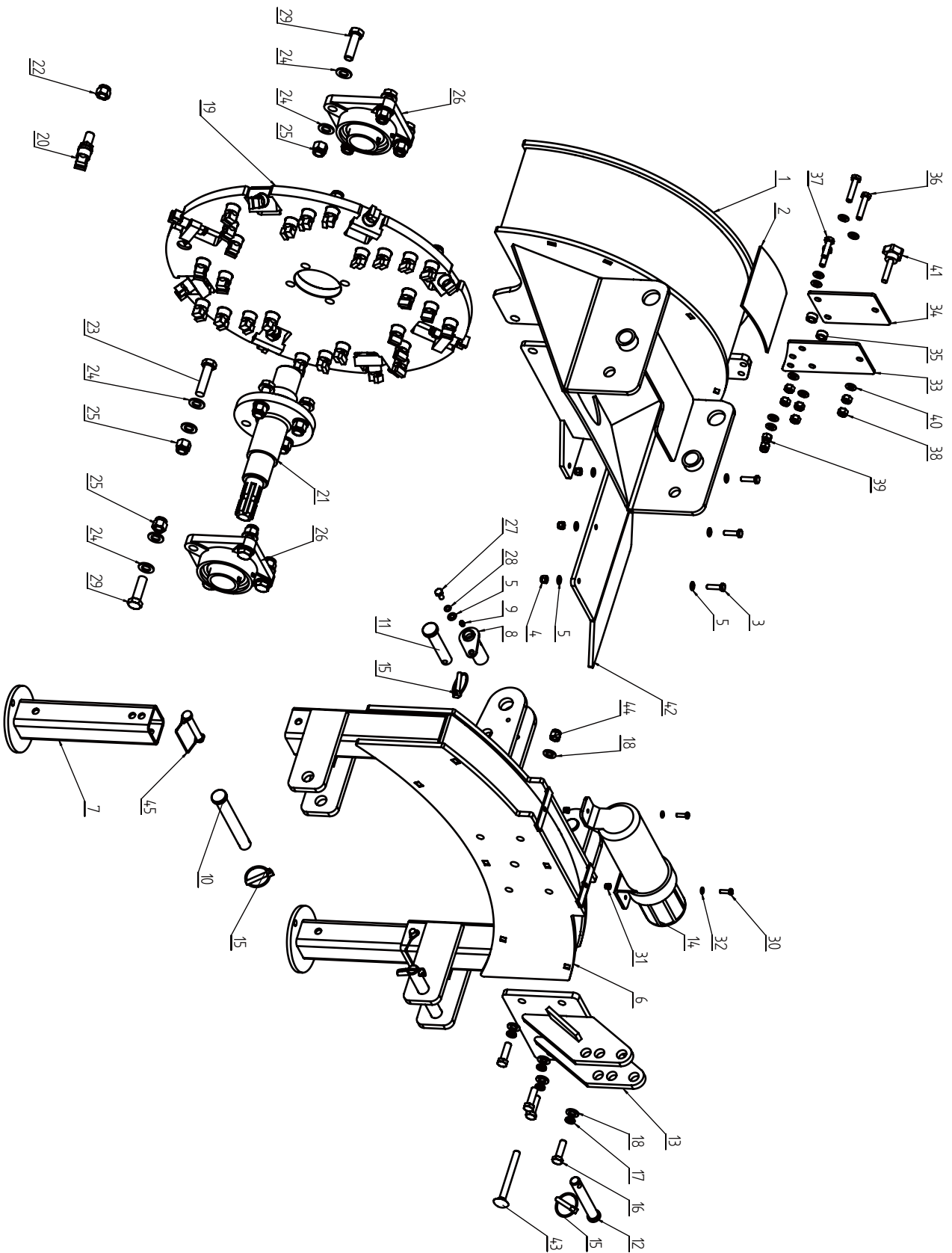

**PARTS LIST**

<b>PART NO.</b>	<b>Description</b>	<b>Qty</b>
1	Main Weldment	1
2	Rubber Pad	1
3	Hex Head Bolt, Full Thread M8×30	3
4	Hex Lock Nut with Non-Metallic Insert, M8	3
5	Flat Washer 8	8
6	Support Weldment	1
7	Support Leg Weldment	2
8	Shaft Weldment	2
9	Straight Grease Fitting M6	2
10	Pin Shaft 22-170	2
11	Pin Shaft 20-110	2
12	Pin Shaft 19-125	1
13	Ear Plate Assembly Weldment	1
14	Large File Bucket	1
15	Ring O-Type Pin M11X45	5
16	Hex Head Bolt, Full Thread M12×40	4
17	Standard Elastic Washer (Assembly) 12	4
18	Flat Washer, Class C 12	5
19	Cutter Disc Weldment	1
20	Cutter Head	34
21	Cutter Spindle	1
22	Hex Lock Nut with Non-Metallic Insert, M16×1.5	34
23	Hex Head Bolt M16×65	4
24	Flat Washer, Class A 16	24
25	Hex Lock Nut with Non-Metallic Insert, M16	12
26	Square Housing Bearing	2
27	Hex Head Bolt, Full Thread M8×16	2
28	Standard Elastic Washer 8	2
29	Hex Head Bolt, Full Thread M16×55	8

PART NO.	Description	Qty
30	Hex Head Bolt, Full Thread M6×20	2
31	Type 2 Hex Lock Nut with Non-Metallic Insert, M6	2
32	Flat Washer, Class C 6	2
33	Clamp Plate 2	1
34	Clamp Plate 1	1
35	Retaining Ring	2
36	Hex Head Bolt, Full Thread M10x50	2
37	Hex Head Bolt, Full Thread M10x35	2
38	Hex Nut M10	6
39	Hex Lock Nut with Non-Metallic Insert, M10	2
40	Flat Washer, Class A 10	9
41	Hand-Tightened Star Bolt	1
42	Baffle Plate	1
43	Round Head Square Neck Bolt M12×120	1
44	Type 2 Hex Lock Nut with Non-Metallic Insert, M12	1
45	Square Lock Pin	2



***MechMaxx***

[info@mechmaxx.com](mailto:info@mechmaxx.com)