

OPERATOR'S SAFETY AND SERVICE MANUAL



R442

This manual covers the following serial numbers
and higher for each model listed:

R442H.....4420784



SMART RAMMERS

MBW, Inc.
250 Hartford Rd • PO Box 440
Slinger, WI 53086-0440
Phone: (262) 644-5234
Fax: (262) 644-5169
Email: mbw@mbw.com
Website: www.mbw.com

MBW Europe Ltd.
Units 2&3 Cochrane Street
Bolton BL3 6BN
England, UK
Phone: +44 (0)1204 387784
Fax: +44 (0) 1204 387797
E-mail: saleseurope@mbw.com
Website: mbw-europe.com

L19904 / 12.23.S
©MBW, Inc. 2015
Printed in the USA

TABLE OF CONTENTS

SAFETY INFORMATION	1	General.....	7
Introduction.....	1	Handle Removal.....	7
Safety Precautions	1	Engine Removal.....	7
SPECIFICATIONS	3	Clutch Removal	7
OPERATION	4	Gearbox Removal	8
Introduction.....	4	Gearbox Disassembly	8
Before Starting & Operating	4	Gearbox Assembly.....	9
Starting Engine.....	4	Lower Unit Disassembly.....	10
Operating	4	Lower Unit Assembly	10
Stopping Engine.....	4	Gearbox and Lower Unit Assembly	11
Lifting and Transporting	4	Parts Replacement Cycles and Tolerances	12
MAINTENANCE	5	REPLACEMENT PARTS	13
Maintenance Schedule	5	Gearbox Assembly.....	14
Fluid Levels.....	5	15
Engine Maintenance.....	5	Lower Unit Assembly	16
Engine Speed.....	5	17
Checking Percussion System Oil	5	Gearbox and Lower Unit Assembly	18
Changing Percussion System Oil.....	6	19
SERVICE	7	Handle Assembly	20
Torque Chart.....	7	21
Service Tools	7	Engine Assembly	22
		23
		WARRANTY	24



WARNING



CALIFORNIA PROPOSITION 65 WARNING

Engine exhaust and some of its constituents and dust produced during the use of this product contain chemicals known in the state of California to cause cancer, birth defects, and other reproductive harm.

SAFETY INFORMATION

Introduction



This Safety Alert Symbol is used to call attention to items or operations which may be dangerous to those operating or working with this equipment.

The symbol can be found throughout this manual and on the unit. Please read these warnings and cautions, along with all decals, carefully before attempting to operate the unit. Make sure every individual who operates or works with this equipment is familiar with all safety precautions.

WARNING

GENERAL WARNING. Indicates information important to the proper operation of the equipment. Failure to observe may result in damage to the equipment and/or severe bodily injury or death.

CAUTION

GENERAL CAUTION. Indicates information important to the proper operation of the equipment. Failure to observe may result in damage to the equipment.

Safety Precautions



LETHAL EXHAUST GAS: An internal combustion engine discharges carbon monoxide, a poisonous, odorless, invisible gas. Death or serious illness may result if inhaled. Operate only in a properly ventilated area. **NEVER OPERATE IN A CONFINED AREA!**



DANGEROUS FUELS: Use extreme caution when storing, handling and using fuels as they are highly volatile and explosive in vapor state. Do not add fuel while engine is running. Stop and cool the engine before adding fuel. **DO NOT SMOKE!**



SAFETY GUARDS: It is the owner's responsibility to ensure that all guards and shields are in place and in working order.



IGNITION SYSTEMS: Breakerless, magneto, and battery ignition systems can cause severe electrical shocks. Avoid contacting these units or their wiring.



SAFE DRESS: Do not wear loose clothing, rings, wristwatches, etc. near machinery.



NOISE PROTECTION: Wear OSHA specified hearing protection devices.



EYE PROTECTION: Wear OSHA specified eye shields, safety glasses, and sweat bands.



FOOT PROTECTION: Wear OSHA specified steel-tipped safety shoes.



HEAD PROTECTION: Wear OSHA specified safety helmets.

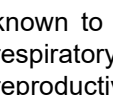

OPERATOR: Keep children and bystanders off and away from the equipment.

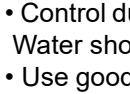

DUST PROTECTION: Machining, crushing or handling of stone, concrete, masonry, metal and other materials may generate dust, mist and fumes containing chemicals such as silica

known to cause serious or fatal injury or illness such as respiratory disease, silicosis, cancer, birth defects, or other reproductive harm.

- Control dust, mist and fumes at the source where possible. Water should be used to control dust whenever feasible.
- Use good work practices and follow the recommendations of the manufacture, OSHA/NIOSH and other occupational trade associations.
- When hazards cannot be eliminated the operator and any bystanders should always wear a OSHA specified respirator for materials being handled.

REFERENCES: For details on safety rules and regulations in the United States, contact your local Occupational Safety and Health Administration (OSHA) office. Equipment operated in other countries must be operated and serviced in accordance and compliance with any and all safety requirements of that country. The publication of these safety precautions is done for your information. MBW does not by the publication of these precautions, imply or in any way represent that these are the sum of all dangers present near MBW equipment. If you are operating MBW equipment, it is your responsibility to insure that such operation is in full accordance with all applicable safety requirements and codes. All requirements of the United States Federal Occupational Safety and Health Administration Act must be met when operated in areas that are under the jurisdiction of that United States Department.

Safety Decals

Carefully read and follow all safety decals. Keep them in good condition. If decals become damaged, replace as required. If repainting the unit, replace all decals. Decals are available from authorized MBW distributors. Order the decal set listed on the following page.

WARNING
OPERATION OF THIS EQUIPMENT MAY CREATE SPARKS THAT CAN START FIRES AROUND DRY VEGETATION. A SPARK ARRESTER MAY BE REQUIRED. THE OPERATOR SHOULD CONTACT LOCAL FIRE AGENCIES FOR LAWS OR REGULATIONS RELATING TO FIRE PREVENTION.

19791

MBW

22595

OPERATING INSTRUCTIONS

1. Check fuel level.
2. Open fuel valve.
3. Set throttle at idle position.
4. Choke engine. A warm engine may not need to be choked.
5. Pull starter rope.
6. After starting, open choke gradually and let engine warm up at idle.
7. To start compacting: open throttle fully.
8. To stop: return throttle to idle and allow engine to run for a few minutes before turning off.
9. Turn engine switch to off and close fuel valve.

14773

CAUTION
Machine is top heavy and could fall if not lifted from this bar.
R422 = 138 lb (63 kg)
R442 = 150 lb (68 kg)
R482/483 = 177 lb (80 kg)

20258

U.S. PATENT 8,057,125

19895

U.S. PATENT 8,202,022

20425

WARNING
Operating, servicing and maintaining this equipment can expose you to chemicals, including engine exhaust, phthalates and lead, which are known to the state of California to cause cancer and birth defects or other reproductive harm. Avoid breathing engine exhaust. Do not operate equipment in confined areas. For more information go to www.P65Warnings.ca.gov

21820

R442

21445

CAUTION
Read Operating Instructions before operating this piece of equipment.
Keep unauthorized and untrained people away from this equipment.
ROTATING & MOVING PARTS! Make sure all guards and safety devices are in place.
Wear OSHA approved hearing protection, foot protection, eye protection and head protection.
Avoid breathing dust from operating machine, wear OSHA specified dust mask/respirator.
SHUT OFF the motor before servicing or cleaning.
DO NOT RUN in an enclosed area. The engine produces carbon monoxide, a **POISONOUS GAS**.
Failure to comply could result in serious bodily injury.

13483

↑ RUN
↓ IDLE
THROTTLE
14770

14770

AIR CLEANER INSTRUCTIONS
CLEAN ELEMENT DAILY. MORE OFTEN UNDER DUSTY CONDITIONS. TAP ELEMENT LIGHTLY ON A FLAT SURFACE. IF DUST DOES NOT DROP OFF EASILY OR IF ELEMENT IS BENT OR CRUSHED, REPLACE IT!
WARNING: DO NOT OPERATE ENGINE WITHOUT AIR CLEANER ELEMENT - INTERNAL DAMAGE WILL RESULT!

06079

DANGER PELIGRO
Compressed spring could cause severe injury. See manual for disassembly instructions.
La resorte comprimida podría causar la herida severa. Consulte el libro para ver el desmontaje correcto.

01326

UNLEADED GASOLINE

14781

OPTIMAL OPERATING SPEED

420-421/422...	3500 RPM
440/442.....	3500 RPM
480-481.....	3200 RPM
482-483.....	3200 RPM

15287

MBW.COM



21743

REMINDER
CHECK ENGINE OIL DAILY. ENGINE MUST BE LEVEL.

15137

Safety Decals (Decal Set #17777)

SPECIFICATIONS

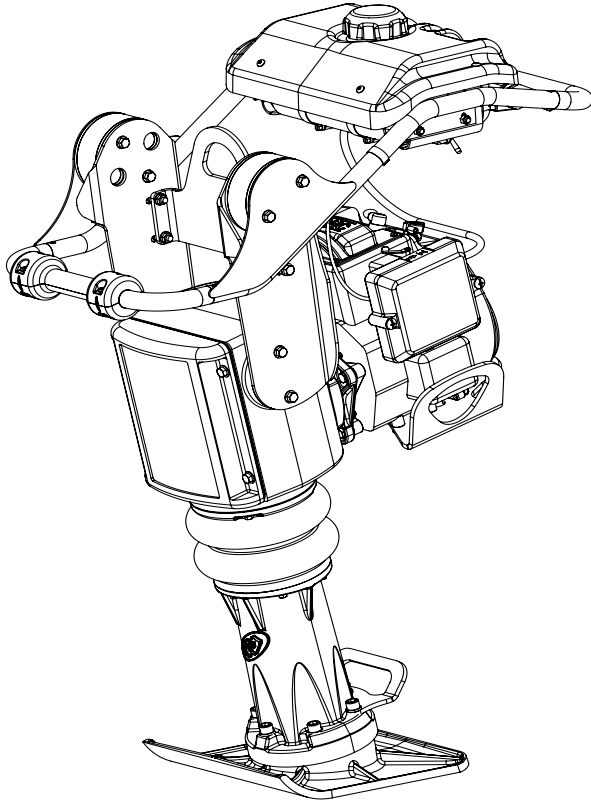

442H/442H12

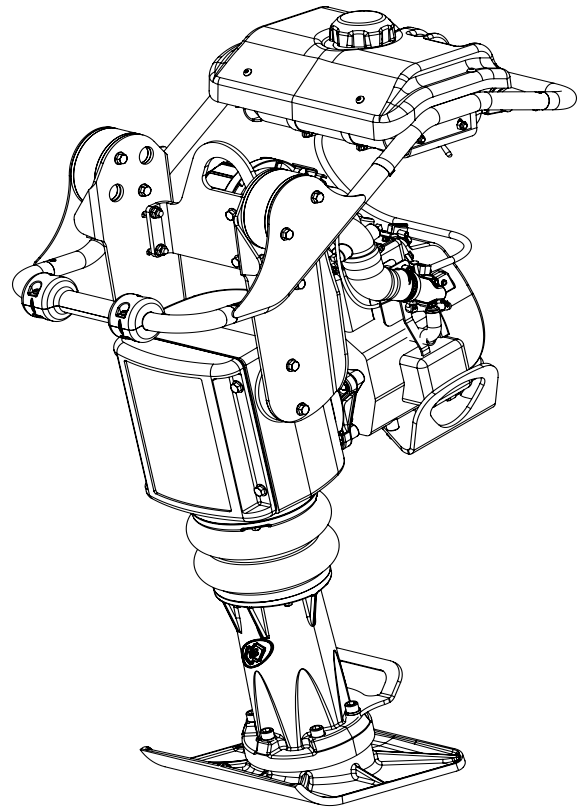

442HA

	442H/442H12	442HA
Operating Weight - lbs (kg)	150 (68)	154 (70)
Height - in (cm)	41 (104)	
Width - in (cm)	15 (38)	
Length - in (cm)	29 (74)	
Engine	Honda GX100/GXR120	Honda GX100
Shoe (W x L) in (cm)	11 x 13 (28 x 33)	
Operating Noise Level¹ dBA	93 dBA	
Compaction Force lbf (kN)	3800 (16.9)	
Travel Speed ft/min (m/min)	55 (16.8)	
Compaction Area sq ft/hr (sq m/hr)	3025 (281)	
Percussion Rate blows/min	up to 720	
Engine Speed rpm	3500	
Fuel Capacity - gal (L)	1.1 (4.2)	
Gearbox Oil Capacity ounces (L)	18 (0.5)	
Engine Oil Capacity ounces (L)	9.6 (0.28)	

Specifications subject to change without notice

1. Noise levels are taken at the operating position and are based on operating conditions. Background noise will increase noise levels.
2. Noise level is operating on loose gravel surface. Hearing protection may be required.
3. Not all product variations shown.

- No universal method or formula has been accepted for determining "Compaction Force". All manufactures employ their own method or formula.

OPERATION

Introduction

MBW equipment is intended for use in very severe applications. They are powered by four cycle engines and are available in different sizes and a selection of engines.

This parts manual contains only standard parts. Variations of these parts as well as other special parts are not included. Contact your local MBW distributor for assistance in identifying parts not included in this manual.

Before Starting & Operating

- **REMEMBER!** It is the owner's responsibility to communicate information on the safe use and proper operation of this unit to the operators.
- Review ALL of the Safety Precautions listed on page 1 of this manual.
- Familiarize yourself with the operation of the machine and confirm that all controls function properly.
- Know how to STOP the machine in case of an emergency.
- Make sure hands, feet, and clothing are at a safe distance from any moving parts.
- **OIL LEVEL** - Check the oil level in the engine. For more information see "Lubrication" under the respective engine's "Owners Manual" or the Maintenance section of this manual.
- **AIR CLEANER** - Check to ensure element is in good condition and properly installed.
- **FUEL SUPPLY** - The engines on MBW equipment require an automotive grade of clean, fresh, unleaded gasoline.
- **FUEL FILTER** - If clogged or damaged, replace.

Starting Engine

For detailed instructions refer to the engine "Owner's Manual".

1. Open fuel valve.
2. Turn engine switch to "ON".
3. Set throttle to idle.

 **CAUTION** 
The engine speed must NOT be high enough to engage the clutch.

4. Choke engine if necessary (you may not need to choke a warm engine).
5. Pull starter rope repeatedly until engine starts.
6. Move choke lever to open position.
7. Allow engine to warm up for one or two minutes.

Operating

1. Familiarize yourself with the balance of the rammer before using it in job conditions. Due to the inherent design, the machine is top heavy and could tip over.
2. After the engine warms up, open the throttle fully for normal operation.
3. On uneven terrain, pushing down on the handle will aid climbing ability.

 **WARNING** 
Do not bear down (body weight of operator) on the machine.

4. After 3 passes, the rammer may have more kick back, this is an indication that ideal compaction is being reached.

Stopping Engine

1. Move throttle to idle position.
2. Let engine idle for one or two minutes.
3. Turn switch on engine to "STOP" position.
4. Turn off fuel valve.

 **WARNING** 
Always stop the engine before:

Adding fuel.

Leaving the equipment unattended for any amount of time.

Before making any repairs or adjustments to the machine.

Lifting and Transporting

1. The unit may be lifted by the handle and engine guard.
2. The unit should be transported laying face down
3. Secure it in place by the handle and shoe. **DO NOT** lay the unit on its sides or face up during transport.

MAINTENANCE



WARNING



Always exercise the stopping procedure before servicing or lubricating the unit.

After servicing the unit, replace and fasten all guards, shields, and covers to their original positions before resuming operation.



CAUTION



Always verify fluid levels and check for leaks after changing fluids.

Do not drain oil onto ground, into open streams, or down sewage drains.

Maintenance Schedule

SYSTEM	MAINTENANCE	DAILY	EVERY 25 HOURS	EVERY 300 HOURS	YEARLY
Air Cleaner	Check and clean	X			
Engine	Refer to engine operator/owner manual	X			
Hardware	Check and tighten as needed ¹		X		X
In Line Fuel Filter	Replace			X	X
Percussion System	Check oil level	X			
	Change oil ²			X	X
Shock Mounts	Check for cracks or deterioration				X
Spark Plug	Replace			X	X

1. Check all hardware after the first 5 hours of use, then follow the maintenance schedule.
2. Change oil in lower unit after the first 50 hours of operation, then follow the maintenance schedule.

Fluid Levels

SYSTEM	FLUID VOLUME	RECOMMENDED OIL
Percussion System	18 oz	SF SAE 10W-30 Motor Oil
Engine	Refer to engine operator/owner manual	

Engine Maintenance

Refer to the engine owner's manual for maintenance intervals and procedures.

- Check and clean the air cleaner element at least once daily. The air cleaner has a foam pre-cleaner that can be washed.
- Check the engine oil level by removing the dipstick (the engine must be level). The oil level should be between the marks on the dipstick. See the "Check Engine Oil" section of the engine "Owner's Manual" for information.
- See the "Change Engine Oil" section of the engine "Owner's Manual" for information on the oil change intervals.

Engine Speed

Engine speed is factory set according to the speed listed in the SPECIFICATIONS section of this manual. Refer to the engine owners manual for procedure on setting operating speed if necessary.

Checking Percussion System Oil

Refer to Lower Unit Assembly, page 16.

The rammer percussion system and gearbox are lubricated by an oil mist which is formed and carried throughout the rammer by a pumping action in the machine's lower system.

1. Before daily operation, place the rammer on a flat surface and check the oil level in the glass sight (#8) on the spring box guard (#13).

2. If the oil is not visible in the sight gauge, add oil as required. See Fluid Levels for recommended type of oil.

Changing Percussion System Oil

Refer to Lower Unit Assembly, page 16.

1. Remove the drain plug (#4) below the sight glass (#8) on the back of the spring box guard (#13).
2. Place an oil drain pan behind the shoe and tip the rammer back so the handle is on the ground.

Refer to Gearbox and Lower Unit Assembly, page 18.

3. With the handle still on the ground, remove the four hex head flange screws (#8) holding the cover (#2) to the gearbox (#4).
4. Remove the cover, the cover gasket (#3), and the dowel pins (#1) from the gearbox.
5. Tip the unit forward and drain any oil into an oil pan.
6. After the oil has drained out, replace the dowel pins, gasket, and cover and secure with the four hex head flange screws.
7. Tip the rammer onto it's face and fill according to the Fluid Levels section in this manual.
8. Replace the drain plug (page 16, #4).

SERVICE

Assembly and disassembly should be performed by a service technician who has been factory trained on MBW equipment. The unit should be clean and free of debris. Pressure washing before disassembly is recommended.

- Prior to assembly, wash all parts in a suitable cleaner or solvent.
- Check moving parts for wear and failure. Refer to the Replacement section in this manual for tolerance and replacement cycles.
- All shafts and housings should be oiled prior to pressing bearings. Also, ensure that the bearings are pressed square and are seated properly.
- All bearings should be replaced when rebuilding any exciter or gearbox.
- All gaskets and seals should be replaced after any disassembly.

Torque Chart

SIZE	GRADE 2	GRADE 5	GRADE 8
1/4-20	49 in•lbs	76 in•lbs	9 ft•lbs
1/4-28	56 in•lbs	87 in•lbs	10 ft•lbs
5/16-18	8 ft•lbs	13 ft•lbs	18 ft•lbs
5/16-24	9 ft•lbs	14 ft•lbs	20 ft•lbs
3/8-16	15 ft•lbs	23 ft•lbs	33 ft•lbs
3/8-24	17 ft•lbs	26 ft•lbs	37 ft•lbs
7/16-14	24 ft•lbs	37 ft•lbs	52 ft•lbs
7/16-20	27 ft•lbs	41 ft•lbs	58 ft•lbs
1/2-13	37 ft•lbs	57 ft•lbs	80 ft•lbs
1/2-20	41 ft•lbs	64 ft•lbs	90 ft•lbs
9/16-12	53 ft•lbs	82 ft•lbs	115 ft•lbs
5/8-11	73 ft•lbs	112 ft•lbs	159 ft•lbs
5/8-18	83 ft•lbs	112 ft•lbs	180 ft•lbs
3/4-16	144 ft•lbs	200 ft•lbs	315 ft•lbs
1-8	188 ft•lbs	483 ft•lbs	682 ft•lbs
1-14	210 ft•lbs	541 ft•lbs	764 ft•lbs
1-1/2-6	652 ft•lbs	1462 ft•lbs	2371 ft•lbs
M 6	3 ft•lbs	4 ft•lbs	7 ft•lbs
M 8	6 ft•lbs	10 ft•lbs	18 ft•lbs
M 10	10 ft•lbs	20 ft•lbs	30 ft•lbs
CONVERSIONS			
in•lbs x 0.083 = ft•lbs			
ft•lbs x 12 = in•lbs			
ft•lbs x 0.1383 = kg•m			
ft•lbs x 1.3558 = N•m			

Service Tools

Part No.	Description
01629	Rubber Test Mat
07552	Blind Hole Bearing Puller Tool

General

The disassembly and assembly procedures given on the next few pages are intended for a complete dismantling of the rammer. Read the following sections carefully. It is not necessary to follow the complete disassembly procedure when only partial disassembly is required. If repairs have to be made to the Lower Assembly only, it is recommended that the drive unit (engine, gearbox and handle) be removed from the lower unit. See "Lower Unit Disassembly".

Handle Removal

Refer to Handle Assembly, page 20.

1. Turn the fuel valve (10) to the OFF position.
2. Loosen the hose clamp (7) at the engine end of the fuel line (9). Disconnect the fuel line.
3. Remove the flat head screws (27) holding the throttle (15) to the handle (20).
4. Remove the four flange head cap screws (32) and flange nuts (33) securing the handle to the torsion mounts (5).
5. Lift the handle (20) from the rammer.

Engine Removal

NOTE: It is not necessary to remove the handle to take the engine off the machine.

Refer to Engine Assembly, page 22.

1. Follow steps 1 through 3 under "Handle Removal".
2. HA Models only, remove hose clamp 38 page 20 from adapter elbow on engine.
3. While supporting the engine, remove the four hex flange nuts (9) holding the engine (8) and engine adapter plate (2) assembly to the studs (1) in gearbox.
4. Remove the engine assembly from the rammer.

Clutch Removal

Refer to Engine Assembly, page 22.

1. Remove the jam (10) nut and slide the clutch off engine crank shaft.

2. Reinstall the clutch, making sure key remains in place and aligned with keyway
3. Reinstall jam nut with medium strength thread locker and tighten to 60 ft lbs (N•m).

Gearbox Removal

NOTE: It is necessary to remove the Handle and the Engine to remove the Gearbox.

Refer to Gearbox and Lower Unit Assembly, page 18.

1. Drain the oil from the rammer following steps 1 through 3 under "Checking Percussion System Oil" on page 5.
2. Replace the drain plug.
3. Remove the four hex head flange screws (#8) holding the cover (#2) to the gearbox (#4).



NOTE: There may be oil in the gearbox. Tip the unit back when removing the cover from the gearbox.

4. Remove the cover (2), the cover gasket (3), and the dowel pins (#1) from the gearbox.
5. Tip the unit forward and drain any oil into an oil pan.
6. Remove retaining ring (6) from piston. Thread a 5/16-18 screw into the piston connecting pin (#5) and remove the pin. See Figure 1.

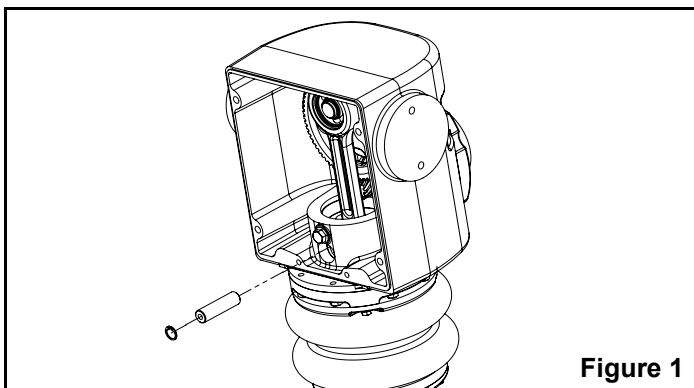

Figure 1

7. Remove the six hex head flange screws (page 16, #23) holding the spring box guard (page 16, #13) to the bottom bellows ring (page 16, #3).

8. Remove the gearbox assembly from the lower unit assembly. See Figure 2.

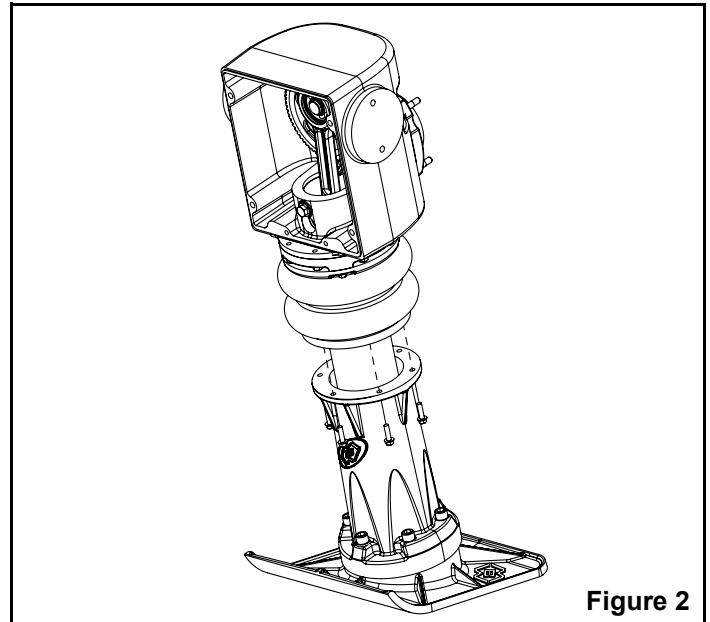

Figure 2

Gearbox Disassembly

Refer to Gearbox Assembly, page 14.

Crank Gear Removal

1. Slip a retaining ring pliers through the slot opening in the crank gear (20) and remove the retaining ring (#10) from the housing. The retaining ring will remain between the crank gear and the bearing (2).
2. Remove the SAE plug (19) from the rear of the gearbox. Use a 3/8 in. or (10mm) diameter steel rod to press the crank gear out of the gearbox.
3. Remove the retaining ring (1) from crank gear (20) and remove ball bearing (2) using a bearing puller. Remove the large retaining ring (10) from the back of the crank gear.
4. Remove the small retaining ring (9) from the front of the offset shaft on the crank gear and remove the connecting rod (5).
5. Remove the needle bearing (6) from the gearbox with a blind hole bearing puller tool (MBW #07552).

Pinion Removal

1. Remove the external retaining ring (4) from the gear end of the pinion (21) on the inside of the gearbox. If the retaining ring is pinched in its groove, tap the pinion on the drum side. This will relieve the pressure on the retaining ring.
2. Press out the pinion.
3. Pry out the oil seal (11) and discard.
4. Remove the retaining rings (#10 & #18).
5. Use a bearing puller to remove the ball bearings (2 & 22).

Breather Removal

1. Remove the hex head cap screw (28) from the top of the breather assembly (14).
2. Remove the plain washer (29), cap (17) and filter (15).
3. Use a pipe wrench to remove the breather tube (16).



Slide Bearing Removal

1. For serial numbers 44200615 and older, remove retaining ring (23) from bottom of gear box guide tube.
2. Pull the slide bearing (#25) out the bottom of the gear box guide tube.



Bellows Removal

Refer to Lower Unit Assembly, page 16.

1. Loosen the four hex head flange screws (22) securing the upper bellows ring (6) to the gearbox.
2. Slide the bellows assembly off the gearbox.
3. Remove upper & lower bellows rings (6 & 3) from bellows (5).

Gearbox Assembly

Refer to Gearbox Assembly, page 14.

1. Press the small ball bearing (22) into the gearbox from the back. Secure with a retaining ring (18).
2. Press the large ball bearing (2) into the gearbox from the back. Secure with a retaining ring (10).
3. Press a new oil seal (11) into the gearbox. Make sure the oil seal is pressed in straight.
4. Lightly oil the lip of the oil seal and the shaft portion of the pinion (21). Carefully press the pinion into the gearbox.



5. Install a retaining ring (4) onto the pinion from inside the gearbox.
6. Press the needle bearing (6) into the gearbox. The bearing must be pressed in with the numbers and letters facing up. Apply a light coat of oil (see Fluid

Levels, page 5 for proper oil type) to the needle bearing after installation.

7. Place a retaining ring (10) over the large shaft of the crank gear (20). Press the ball bearing (2) onto the crank gear.
8. Install a retaining ring (1) to secure the ball bearing to the crank gear shaft.
9. Press the bearing (3) into the connecting rod (5) and secure with a retaining ring (8).
10. Press the connecting rod (5) onto the offset shaft of the crank gear (20).
11. Install a retaining ring (9) to secure the connecting rod.
12. Press the crank gear assembly into the gearbox. Install the snap ring (10) using a retaining ring pliers inserted through the slot in the crank gear.
13. Install the SAE plug (19) into the gearbox. Do not over tighten.
14. Replace the breather tube sub-assembly (16), filter (15), cap (17), and plain washer (29). Apply medium strength thread locking liquid to the threads of the hex head cap screw (28) and install.
15. Slide the slide bearing (25) with the holes up into the gearbox tube and align the hole in the bearing with the access hole in the gearbox.
16. Install retaining ring (23) for units with ring groove in guide tube.
17. Assemble the lower bellows ring (page 16, #3) to one side of the bellows (page 16, #5).
18. Assemble the upper bellows ring (page 16, #6) to the other side of the bellows.
19. Insert four hex head flange screws (page 16, #22) through the upper bellows mount so the head of the screw is wedged between the bellows and the upper bellows mount.
20. Slide the bellows assembly over the gearbox guide tube (page 18, #4) with the upper bellows ring toward the gearbox.
21. Thread the hex head flange screws into the gearbox to secure the bellows.

Apply a light coat of oil (see Fluid Levels, page 5 for proper oil type) to all bearings after installation is complete.

Lower Unit Disassembly

NOTE: The lower unit can be separated from the drive unit (engine, gearbox and handle) without completely disassembling the rammer. If the lower unit has not already been separated, follow the “Gearbox Removal” instructions.

Refer to Lower Unit Assembly, page 16.

Shoe and Spring box Guard Removal

1. Remove the six socket head cap screws (4 & 5) and lock washers (6) that secure the shoe (2) to the lower unit assembly and remove the shoe.
2. Lift the spring box guard (3) off the spring box assembly.
3. Remove the o-ring (#) from the spring box guard (13).

Spring box Disassembly

WARNING
Working with compressed springs! Failure to follow the next set of steps very carefully could result in injury or death.

1. Flip the spring box assembly upside down.
2. Insert the spring box tool (MBW #20260) rods into the spring box assembly as shown in Figure 3.

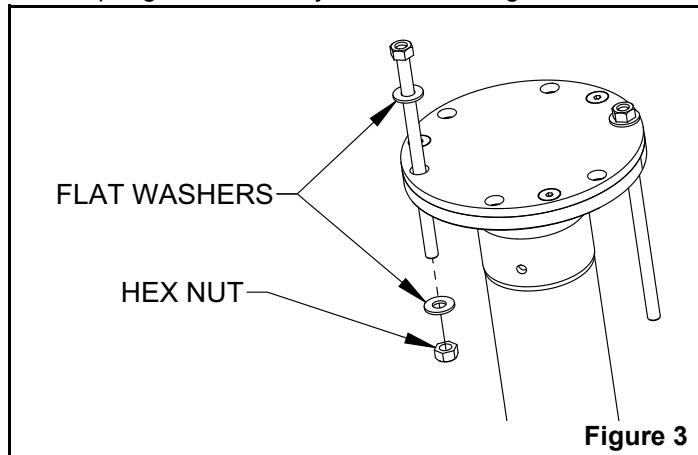

3. Make sure the rods are 180° apart.
4. Place the washers over the rods and run the nuts down so the washers are snug against the cover (#1).
5. Remove the flat head socket screws (21) holding the cover to the spring box.
6. While holding the hex nuts from turning, slowly and evenly back off the rods on the cover side of the spring box.
7. After the tension is removed from the cover, the spring box tools and the cover can be removed. See Figure 4.
8. Remove the o-ring (2) from the cover.

9. The lower springs (9, 10 & 11) can be removed from the spring box (18).
10. Place a drift pin or 5/8" dia. steel rod into the connecting pin hole in the ram head (19). Use this to hold the ram head from turning while removing the deformed flange lock nut (27). Remove and discard flange lock nut.
11. Remove the spring separator (14) and slide bearing (15).
12. Remove upper springs (9, 10 & 11) and ram shaft (19).
13. Remove the retaining ring (17) and ram shaft slide bearing (16) from top of spring box (18).

Lower Unit Assembly

WARNING
Working with compressed springs! Failure to follow the next set of steps very carefully could result in injury or death.

Refer to Lower Unit Assembly, page 16.

1. Install the ram shaft slide bearing (16) and retaining ring (#7) into the top of spring box (18).
2. Install ram shaft (19) into top of spring box.
3. Turn spring box (18) up side down and install the upper springs (9, 10 & 11).
4. Wrap slide bearing (15) around spring separator (14) and install into spring box.
5. Apply high strength (red) thread locker to threads of new flange lock nut (27) and assemble to the ram shaft. Torque to 60 ft lbs (81 N•m).
6. Insert the lower springs (9, 10 & 11).
7. Lightly grease the o-ring groove in the cover (1) and install a new o-ring (2).
8. Insert the spring box tool (MBW #20260) rods into the spring box as shown in Figure 4.

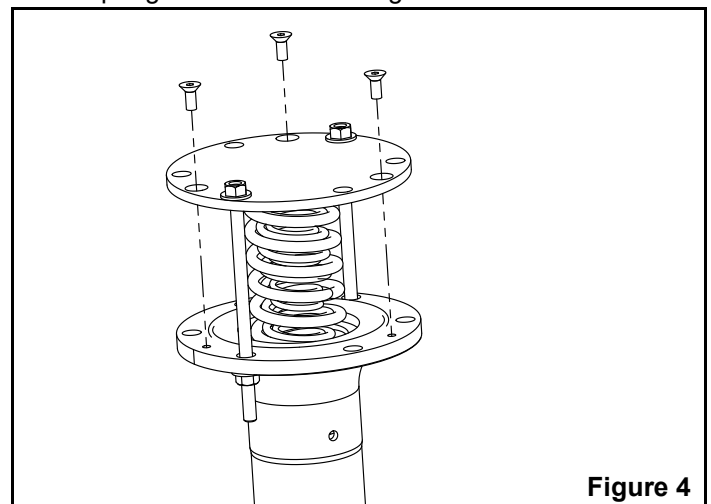

9. Slowly draw the cover down onto the spring box by alternately tightening each rod.



10. Secure the cover with three flat head socket screws (#21) torqued to 8 ft lbs (11 N•m).
11. Remove the spring box tool rods from the assembly.
12. The spring box warning decal (page 2, #01326) should be clean and highly visible. If not, the old decal should be completely removed and replaced with a new decal.
13. Lightly oil a new o-ring (7) and place it into the groove in the spring box guard (13).
14. Slide the spring box guard over the ram head onto the spring box. Be careful not to damage the o-ring during installation.
15. Place the spring box assembly onto the shoe (12) with the fill plug (8) pointing toward the back of the shoe.
16. Install six socket head cap screws (24 & 25) as shown and lock washers (26). Torque the cap screws to 40 ft lbs (56 N•m).

9. Align the holes in the cover (2) with the dowel pins and place the cover on the gasket.
10. Secure the cover to the gearbox using four flange head screws (8). Tighten the flange screws equally and torque to 13 ft lbs (18 N•m).
11. The gasket will compress slightly after initial tightening, re-torque the flange screws after 5 minutes.
12. If the handle brackets (page 20, #12 & #13) were removed, reinstall with flange head cap screws (page 20, #22). Torque to 35 ft lbs (47 N•m).
13. Fill the unit with oil according to the Changing Percussion System Oil section on page 6.

Gearbox and Lower Unit Assembly

Refer to Gearbox and Lower Unit Assembly, page 18.

1. Rotate the ram head (page 16, #19) in the lower unit so the larger hole on top is positioned toward the front of the shoe (page 16, #12).
2. Slide the gearbox assembly onto the lower unit.
3. Align the connecting rod (page 14, #5) with the ram head and install the piston connecting pin (5) with the threaded hole in the pin facing out.
4. Install retaining ring (6) into ram head. Be sure retaining ring is completely seated into groove in ram head.
5. Rotate the gearbox assembly so the front of the gearbox is aligned with the front of the lower unit.
6. Secure the lower bellows mount (page 16, #3) to the spring box guard (page 16, #13) using six hex head flange screws (page 16, #23). Torque to 12 ft lbs (16 N•m).
7. Tip the assembly back and place a new gasket (3) over the gearbox face.
8. Insert the dowel pins (1) into the gearbox through the holes in the gasket.

Parts Replacement Cycles and Tolerances

Bearings	Replace anytime a bearing is rough, binding, discolored or removed from housing or shaft.
Bellows	Replace when they are worn, cracked, or to the point of leaking.
Clutch	Replace clutch if shoes and/or springs show signs of heat damage or if it does not disengage below 2000 rpm.
Crank Gear	Replace if teeth are cracked or if they become sharp.
Engine Components	Refer to your engine manufacturer's Owner's Manual.
Guide Bushings	Replace if a 0.025" (0.635 mm) feeler gauge can be slid between the spring box and the guide tube.
Hardware	Replace any worn or damaged hardware as needed. Replacement hardware should be grade 5 and zinc plated unless otherwise specified.
Pinion	Replace if teeth are cracked or if they become sharp. Replace if the drum is scored or gouged deeper than 0.03" (0.76 mm).
Piston (Spring box)	Replace if a 0.025" (0.635 mm) feeler gauge can be slid between the spring box and the piston.
Piston Pin	Replace if the outside diameter is less than 0.620" (15.75 mm).
Safety Decals	Replace if they become damaged or illegible.
Seals & Gaskets	Replace if a leak is detected and at every overhaul or tear-down.
Springs	Replace if a flat spot on the side of a spring is greater than 0.09" (2 mm). Replace if the free length is less than 6.75" (171 mm). Replace ALL springs at the same time.

REPLACEMENT PARTS

The warranty is stated in this book on page 24. Failure to return the Warranty Registration Card renders the warranty null and void.

MBW has established a network of reputable distributors/dealers with trained mechanics and full facilities for maintenance and rebuilding, and to carry an adequate parts stock in all areas of the country. Their sales engineers are available for professional consultation. If you cannot locate an MBW distributor in your area, contact MBW or one of our Sales Branches listed below.

When ordering replacement parts, be sure to have the following information available:

- Model and Serial Number of machine when ordering MBW parts
- Model and Serial Number of engine when ordering engine parts
- Part Number, Description, and Quantity
- Company Name, Address, Zip Code, and Purchase Order Number
- Preferred method of shipping

REMEMBER - You own the best! If repairs are needed, use only MBW parts purchased from authorized MBW distributors.

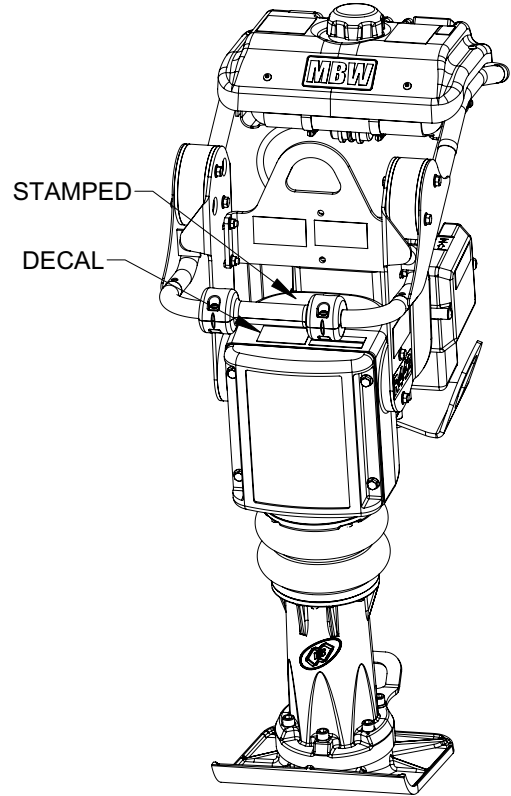

The unit's serial number can be found in the following locations:

- The serial number decal is located on the top of the gearbox.
- The serial number is also stamped on the top of the gearbox.

Write Model Number here

Write Serial Number here

Contact Information

MBW, Inc.

250 Hartford Rd • PO Box 440
Slinger, WI 53086-0440
Phone: (262) 644-5234
Fax: (262) 644-5169
Email: mbw@mbw.com
Website: www.mbw.com

MBW Europe Ltd.

Units 2&3 Cochrane Street
Bolton BL3 6BN
England, UK
Phone: +44 (0) 1204 387784
Fax: +44 (0) 1204 387797
E-mail: saleseurope@mbw.com
Website: mbw-europe.com

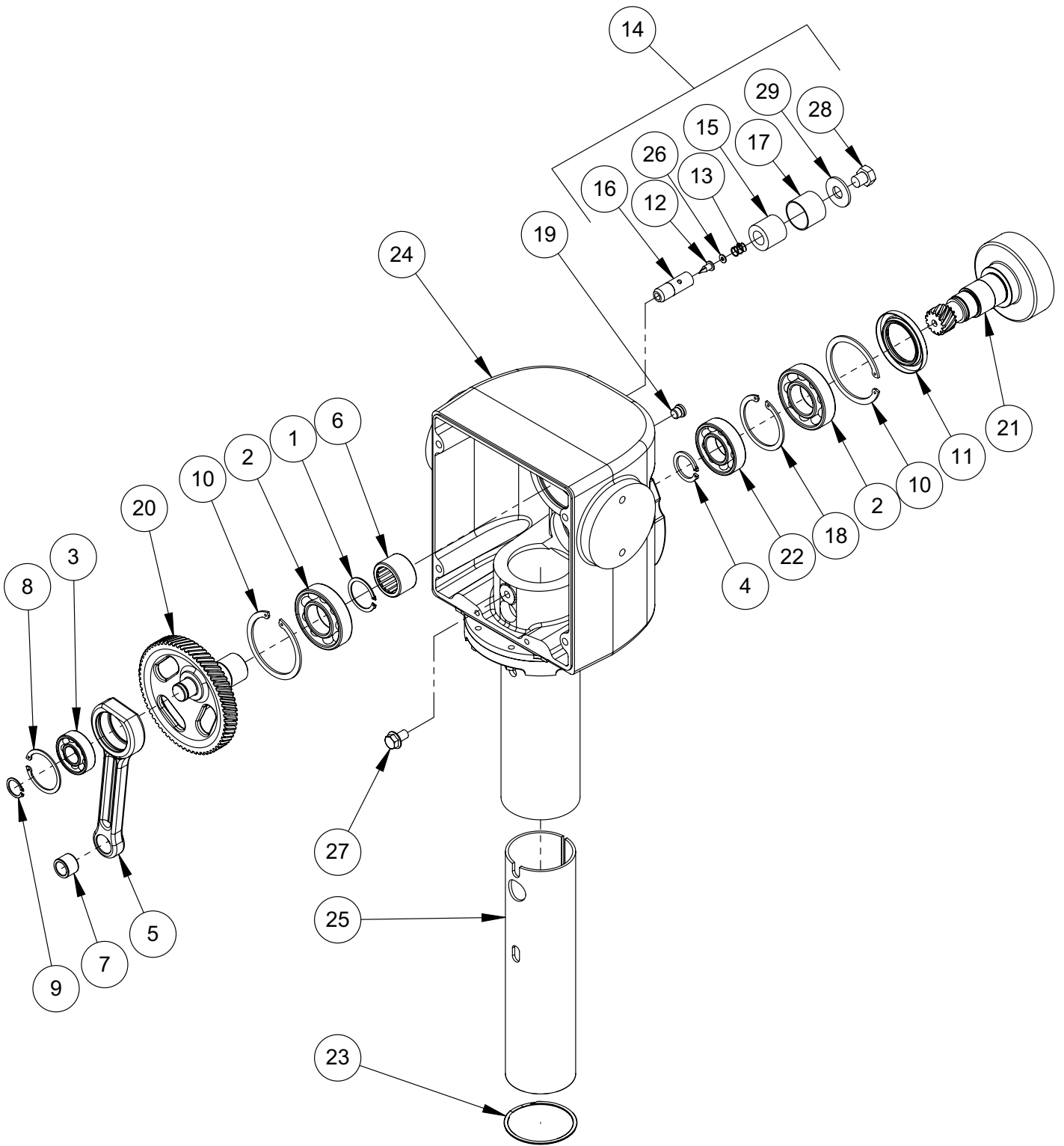

Gearbox Assembly

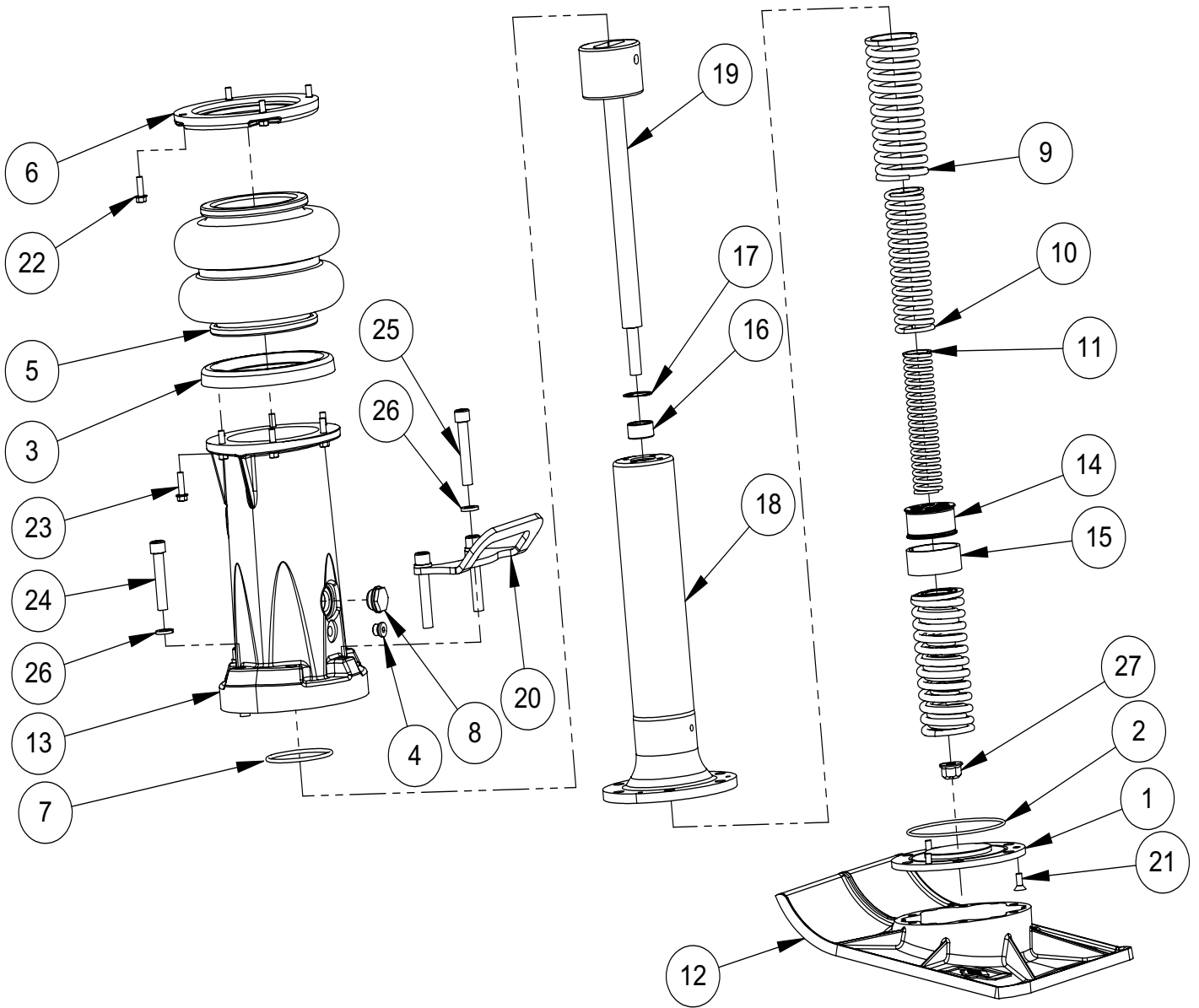

Lower Unit Assembly

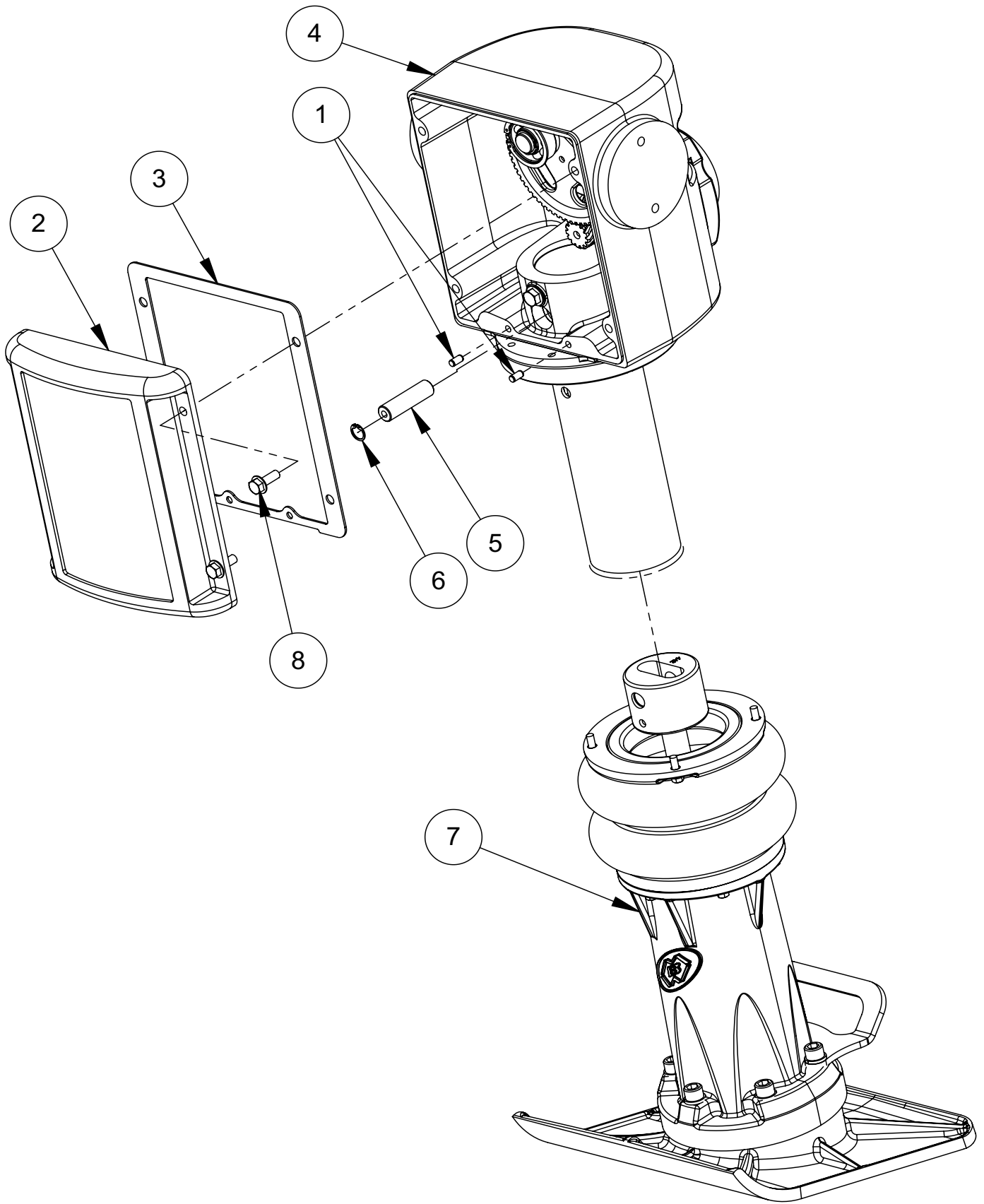

Gearbox and Lower Unit Assembly

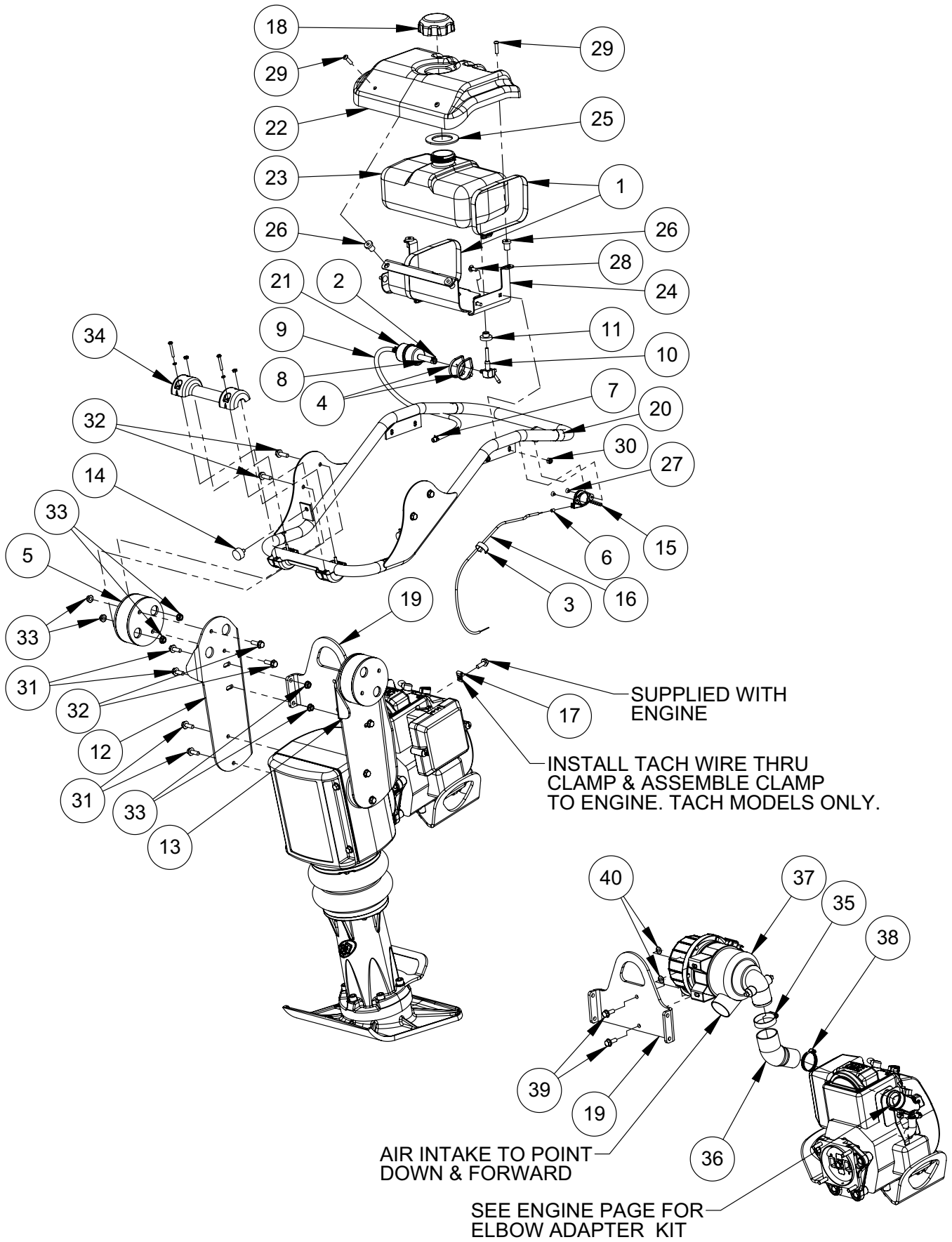

Handle Assembly

ITEM	PART NO.	DESCRIPTION	QTY
1.	01026	WORM DRIVE CLAMP	2
2.	01052	CLAMP, 1/4" FUEL HOSE	2
3.	01145	CLAMP, SPRING	1
4.	01291	CABLE TIE, 3/16 X 7-1/2, BLACK	2
5.	07351	TORSION MOUNT	2
6.	07916	FERRULE, THROTTLE LEVER	1
7.	15016	CLAMP, 3/16" FUEL HOSE	2
8.	15183	HOSE, FUEL, 1/4" X 2"LG.	2
9.	20303	HOSE, FUEL, 3/16 I.D. x 20" lg.	1
10.	16414	VALVE, FUEL	1
11.	16586	GROMMET, 1/2"	1
12.	18510	HANDLE SUPPORT, RIGHT	1
13.	18511	HANDLE SUPPORT, LEFT	1
14.	18515	SNUBBER	2
15.	18742	THROTTLE, RATCHET, FLANGE MOUNT	1
16.	19899	CABLE, THROTTLE	1
17.	14946	CLAMP, TACH WIRE	1
18.	20476	CAP, 2-1/4", EPA	1
19.	20713	BRACKET, LIFTING	1
20.	20719	HANDLE, COATED	1
21.	18883 21700	HANDLE, COATED (For serial number 4420599 and lower) FUEL FILTER, IN-LINE	1
22.	21840	SHROUD, RAMMER HANDLE	1
23.	21842	FUEL TANK, ONE GALLON, EPA	1
24.	21844 21875	MOUNTING BRACKET, FUEL TANKS KIT, FUEL TANK UPDATE (For serial number #4220xxx and lower)	1
25.	21847	GASKET, FUEL TANK	1
26.	21848	WELLNUT, 1/4-20	4
27.	F032402FSS	FLAT HEAD SOCKET SCREW, 10-24 X 1/4" ZP	2
28.	F042005CB	CARRIAGE BOLT, 1/4-20 X 5/8 LG.	4
29.	F042008BCS	BUTTON HEAD SCREW, 1/4-20 X 1.0	4
30.	F04ELN	NYLON LOCK NUT, 1/4-20	4
31.	F051807FWS	FLANGE SCREW, 5/16"-18 x 7/8"	8
32.	F051808FWS	FLANGE SCREW, 5/16"-18 x 1" ZP	8
33.	F0518FN	NUT, FLANGE 5/16"-18 ZP	16
34.	20549	KIT, HANDLE ROLLER	1
		AIR CLEANER COMPONENTS, FOR "HA" MODELS ONLY	1
35.	09215	CLAMP, ADAPTER TUBE, AIR CLEANER	1
36.	20544	ADAPTER TUBE, AIR CLEANER	1
37.	20714	AIR CLEANER	1
38.	20716	CLAMP, WORM DRIVE	2
39.	F051807FWS	FLANGE SCREW, 5/16"-18 x 7/8"	2
40.	F0518FN 20715	NUT, FLANGE 5/16"-18 ZP REPLACEMENT AIR FILTER (NOT SHOWN)	2
	20718	EJECTOR BOOT, AIR CLEANER HOUSING (NOT SHOWN)	
		OPTIONAL ACCESSORIES	
	20305	KIT, FUEL HOSE ASSEMBLY (Includes items #2, 7, 8, 9 & 21)	

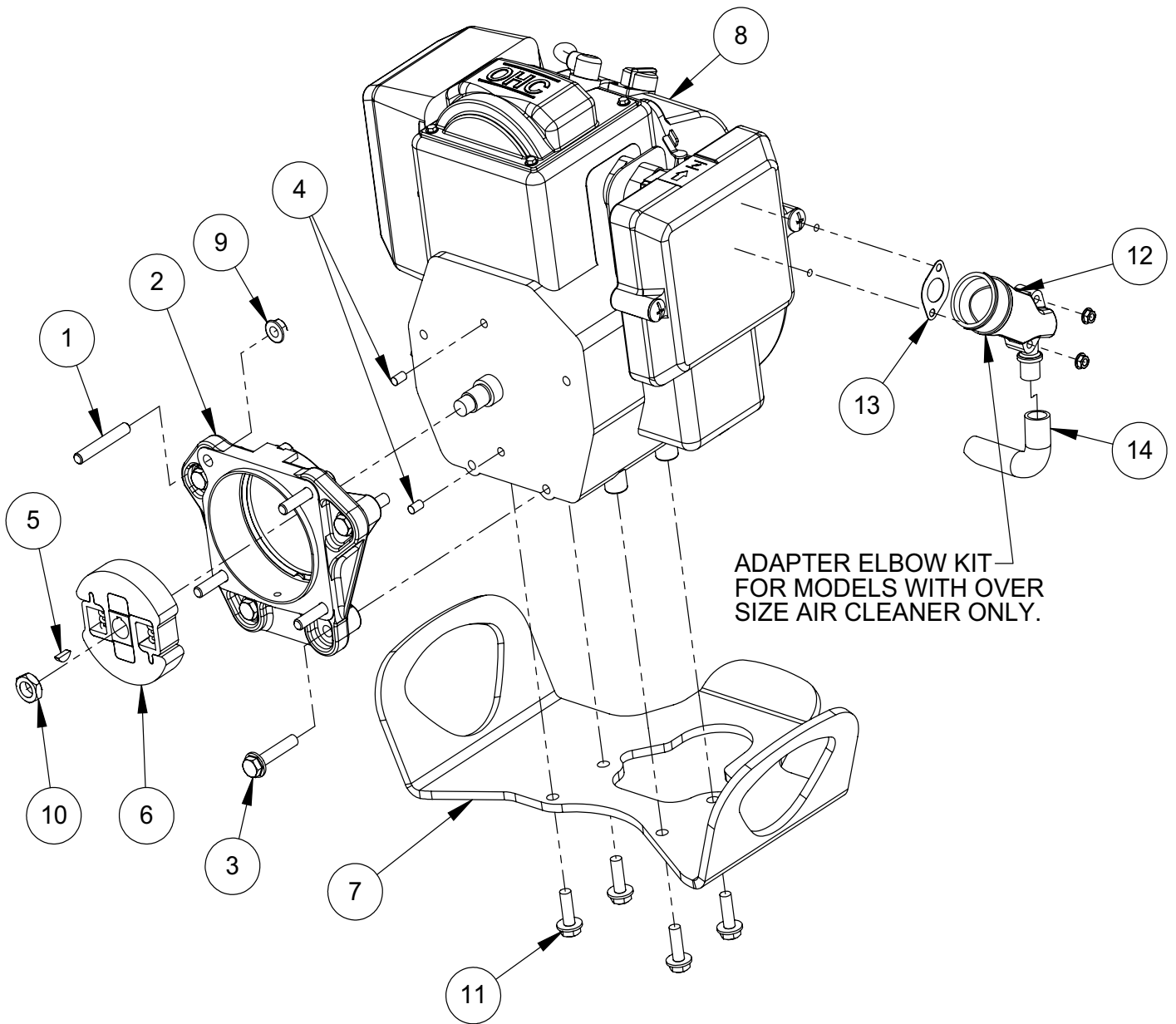

Engine Assembly

WARRANTY

1. IN GENERAL - The warranties described in this document are provided by M-B-W, INC. and MBW EUROPE, LTD. ("MBW") to define what is, what is not, and for how long machines and parts are covered against material defects and/or defective workmanship. To obtain warranty service, the purchaser must, within the Warranty Period (defined in Paragraph 3): (i) report the product defect to an authorized repair center, (ii) make a written request for repair, (iii) provide proof of purchase to the authorized repair center, and (iv) deliver the equipment to the authorized repair center. A list of authorized repair centers is available on the MBW website (mbw.com) or by contacting MBW at 800-678-5237.

2. COVERED - MBW's obligation under this limited warranty is limited to the cost of the parts and the labor to repair any defect in material and/or workmanship at an authorized MBW repair center. Transportation charges are not covered by this limited warranty.

3. WARRANTY PERIODS - The Warranty Period begins on, as applicable: (i) the product purchase date by an end user or (ii) the first day the product is put into rental or two years after invoice date from MBW to Dealer, whichever starts the warranty period first. To insure that your warranty is in place, fill out the warranty card and mail it in or register your product online at www.mbw.com/service-support/warranty-registration. The warranty is nontransferable.

The Warranty Period ends after:

- A. New Ground compaction equipment - 2 years.
 - B. New Concrete finishing equipment - 1 year.
 - C. New Utility equipment - 1 year.
 - D. Demonstration equipment - 6 months.
 - E. Wear parts: lubricants, filters, belts and shock mounts - 30 days.
4. NOT COVERED- This warranty does not include, and MBW specifically excluded from any warranty:
- A. Used equipment - all used equipment is not warranted and is sold 'as is' 'where is' with all defects.
 - B. Replacement electrical parts, including but not limited to: electric motors, circuit boards, switches, are not warranted or returnable.
 - C. OEM: engines, batteries, and chargers. Those warranties are covered by the manufacturer.
 - D. Consumable parts: trowel and screed blades.
 - E. Equipment that has been: altered, abused, neglected, not maintained, or modified to run outside its specifications. Any modification to the machine or its parts makes this warranty null and void.
 - F. Other: damage to a product from normal wear, air freight, overtime, pickup and delivery, temporary replacement rentals, freight damage, or other similar incidents.
 - G. Product used in a fashion it was not designed for.
 - H. Parts and labor not performed by authorized dealers.

It is at MBW's discretion if warranty applies and has the right to adjust labor rates on a claim by claim basis.

5. OTHER - IT IS EXPRESSLY AGREED THAT THIS SHALL BE THE SOLE AND EXCLUSIVE REMEDY UNDER THIS WARRANTY. UNDER NO CIRCUMSTANCES SHALL MBW BE LIABLE FOR ANY COSTS, LOSS, EXPENSE, DAMAGE, SPECIAL DAMAGES, DIRECT DAMAGES, INCIDENTAL DAMAGES, EXEMPLARY, CONSEQUENTIAL, OR PUNITIVE DAMAGES ARISING DIRECTLY OR INDIRECTLY FROM THE USE OF MBW PRODUCT OR DAMAGES FOR LOSS OF USE, LOSS OF ANTICIPATED PROFITS, INCOME, OR ECONOMIC LOSSES OF ANY KIND. MBW'S LIABILITY TO BUYER UNDER THESE WARRANTIES FOR THE PRODUCT IS LIMITED AS SET FORTH HEREIN, WHETHER BASED UPON WARRANTY, CONTRACT, NEGLIGENCE, TORT, STRICT LIABILITY OR ANY OTHER THEORY OF LIABILITY, INCLUDING BUT NOT LIMITED TO FRAUD, MISREPRESENTATION, BREACH OF CONTRACT, PERSONAL INJURY, PRODUCTS LIABILITY OR ANY OTHER THEORY.

MBW'S LIABILITY UNDER ANY WARRANTY HEREUNDER, WHETHER EXPRESS OR IMPLIED, SHALL NOT EXCEED THE COST OF REPAIR OR REPLACEMENT OF DEFECTIVE PARTS OF THE PRODUCT OR THE PRODUCT. BUYER MAY NOT BRING ANY ACTION UNDER THESE WARRANTIES MORE THAN ONE YEAR AFTER THE CAUSE OF ACTION HAS ACCRUED.

THE FORGOING WARRANTY IS EXPRESSED IN LIEU OF ALL OTHER WARRANTIES, EXPRESSED OR IMPLIED, INCLUDING THE WARRANTIES OF MERCHANTABILITY, FITNESS FOR USE, AND FITNESS FOR A PARTICULAR PURPOSE, AND ALL OTHER OBLIGATIONS OR LIABILITY ON MBW'S PART. MBW SPECIFICALLY DISCLAIMS AND EXCLUDES ANY AND ALL WARRANTIES OF MERCHANTABILITY AND FITNESS FOR A PARTICULAR PURPOSE.

MBW NEITHER ASSUMES NOR AUTHORIZES ANY OTHER PERSON TO ASSUME ON BEHALF OF MBW ANY OTHER LIABILITY OR WARRANTY IN CONNECTION WITH THE SALE OR SERVICE OF ANY MBW PRODUCT.

Some states do not allow limitations on how long an implied warranty lasts, so the above limitation may not apply to you. This warranty gives you specific legal rights, and you may also have other rights which vary from state to state.

NOTES: