

TX1000

HYDRAULIC
WOOD
CHIPPER



Operator's Manual

CROBA

READ AND UNDERSTAND THE ENTIRE MANUAL BEFORE OPERATING MACHINE

TABLE OF CONTENTS

SPECIFICATIONS	2	TRANSPORTATION	25
SAFETY LABELS	6	MAINTENANCE	26
GENERAL SAFETY	8	TROUBLESHOOTING	30
CONTENTS SUPPLIED	14	PARTS DIAGRAM	32
ASSEMBLY	15		
KNOW YOUR MACHINE	17		
OPERATING INSTRUCTIONS	20		

SPECIFICATIONS

Model	TX1000
Engine Parameter	
Engine Brand Model	Zonsen GB1000EI
Engine Power	35HP
Torque	74Nm
Fuel Tank Capacity	18L
Max Fuel Consumption	2.38gal/h
Fuel Type	Gasoline 92#
Air Cleaner	Double filtration
Oil Filter	Screw mounting
Recommended Oil	SAE 10W-30
Oil Volume With Filter	2.5L
Maximum Continuous Working Angle	20°
Cooling Medium	Forced cooling
Alternator	25A/300W
Clutch Type	Manual clutch
Engine Shaft Diameter	1.125 in
Tensioner	Spring automatic tensioning
Belt	2SB1505LE
General Dimensions And Weight	
Overall Length-Feed Table Up	135 in
Overall Length-Feed Table Down	155 in
Overall Width	55 in
Overall Height-Discharge Chute Up	79 in
Overall Height-Discharge Chute Down	92 in
Overall Weight	1874 lbs
Tongue Weight	198 lbs

Feed System	
Feed Roller Orientation	Horizontal
Feed Roller Nos.	1
Feed Roller Clamp Load	344 lbs
Knife Nos.	4
Number Of Feed Roller Motors	1
Feed Roller Clamping Mechanism Type	Spring + feeding roller weight
Feed Roller Dimension	φ 12*11 in
Minimum Distance From Feed Roller To Blade Housing	5 in
Weight Of Feed Roller Assembly	123 lbs
Feed Speed	54ft/min
Infeed Table Height	22 in
Infeed Table Length	24 in
Infeed Table Width	41 in
Infeed Throat Size	12*8 in
Distance From feed roller to end of feed table	61 in
Distance From feed table to ground	30 in
Safety System	
Bottom feed stop bar function	Feed roller stopped - reset
Bottom feed stop bar	Standard
Bottom feed stop bar diameter	1.2 in
Bottom feed stop bar material thickness	0.07 in
Stop bar resetting Method	manual reset
Three-position feed control bar	Standard
control bar diameter	1 in
Control bar material thickness	0.07 in
Control bar position function	Forward/stop/reverse
Red emergency stop button	Stop the engine
Red emergency stop button reset method	manual reset

Blade Housing parameter	
Chipping Capacity	8 in
Blade housing width	7 in
Cutting disc size	30*0.7 in
Cutting disc rotating speed	1800
Weight with shaft	225 lbs
Safety lock - number of positions	1
Blade size	4*1*0.5 in
Blade cutting edge Nos.	2
Blade bolt Nos.	3
Vertical anvil size	3.5*7.8*0.5 in
Vertical anvil cutting edge Nos.	2
Horizontal anvil size	3.7*11.6*0.4 in
Horizontal anvil cutting edge Nos.	2
Blade material	A8 steel
Anvil material	Cr12
Blade holder replaceable	No
Fan blades Nos.	4
Fan blade fixation method	Bolt fixing
Fan blade air flow	92 m ³ /min
Disc	
Bearing Nos.	2
Bearing hole diameter	2 in
Bearing type	Spherical bearing
Bearing brand	skf
Dynamic capacity	23.2KN
Static capacity	27KN
Tensioner	Automatic tensioning
Belt type	Combined belt

Discharge System	
Chute height	97 in
Flange thickness	0.2 in
Side wall thickness	0.07 in
chute rotation angle	360°
Rotation type	Manual
Rotatation lock included?	Yes
Rotational lock type	Tighten the dual handle bolts
Hydraulic System	
Tank capacity	7.4 Gallon
Recommended oil type	hm46
system type	open center
Filtration method	Return oil filtration - 10um
Pump flow at the maximum RPM	4.2gal
Maximum pressure	2102psi
Electric Control Parameter	
System voltage	12V
Battery	12V 48AH
Display screen size	4.3 in.
Controller Function	Timer, automatic control, status display, speed display, etc.
Shutdown system	Engine
Trailer lights	Vehicle power supply
Others	
Tow ball size	2" Coupler hitch / 2" ball coupler
Hook type	ball coupler
Axle load-bearing capacity	2756 lbs torsion shaft
Mud guard	Bolt fixing
Torque shaft type	Solid torque shaft
Tyre	φ594x165R13

SAFETY LABELS

Safety sign locations on the equipment are shown in the illustrations that follow. Good safety requires that you familiarize yourself with the various safety signs, the type of warning and the area, or particular function related to that area, that requires your SAFETY AWARENESS.

Safety Sign Explanations













IMPORTANT!

If parts are replaced that have safety signs on them, new signs must be applied. Safety signs must always be replaced if they become damaged, are removed, or become illegible.

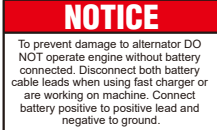
Safety signs are included in the product decal kit available from your authorized dealer. Decals are not available separately

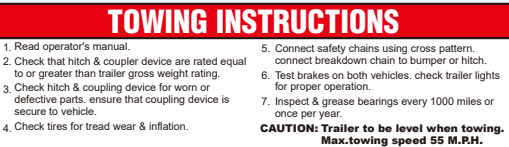
1		Before you use the machine, please read the instruction manual carefully and pay attention to the relevant safety information.	2		Please wear safety gear and heed all safety information.
3		Before you start the machine, please read the instruction manual to avoid hazards resulting from improper operation.	4		Stay away from all moving parts to avoid hazards.
5		Moving belts & spinning blades inside. Always keep covers in place while the machine is in operation.	6		Binding position.
7		Lube every six months until grease appears at headshaft hub.			

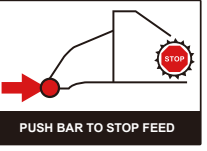
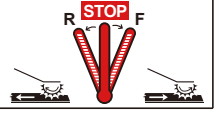
<p>8</p> 	<p>Moving belts & spinning blades inside. Always keep covers in place while the machine is in operation.</p>	<p>9</p>  <p>Read and understand Operator's Manual before using machine.</p>	<p>Read and understand Operator's Manual before using machine.</p>
<p>10</p>  <p>CHECK TIRE CONDITION AND INFLATION DAILY! Under-Inflated Tires Can Cause Unsafe towing conditions, resulting in roll-over or vehicle accident. Under-inflation causes tire damage.</p>	<p>Daily, check your tire condition and inflation!</p>	<p>11</p>  <p>CHECK ALL FLUIDS DAILY USE APPROVED OILS, LUBRICANTS, COOLANTS</p>	<p>Daily, please check all fluids.</p>
<p>12</p> 	<p>Please stay away from the discharge port and wear safety gear.</p>	<p>13</p>  <p>NOTICE Proper personal safety gear and proper snug-fitting protective clothing. Loose clothing may become entangled in moving machinery causing injury or death.</p>	<p>Proper personal safety gear and proper snug-fitting protective clothing.</p>
<p>14</p>  <p>NOTICE To prevent damage to alternator DO NOT operate engine without battery connected. Disconnect both battery cable leads when using fast charger or are working on machine. Connect battery positive to positive lead and negative to ground.</p>	<p>To prevent damage to alternator DO NOT operate engine without battery connected.</p>	<p>15</p>  <p>DANGER • Never reach inside infed chute. • Never operate this machine when wearing loose clothing, scarves, or gauntlet gloves, or gloves with large cuffs or holes. • Never operate this machine alone. Make certain there are at least two people with this machine at all times. • Never operate this machine without thoroughly reading the operator's manual.</p>	<p>Before you use this product, please read the safety instructions carefully.</p>
<p>16</p>  <p>TOWING INSTRUCTIONS</p> <ol style="list-style-type: none"> 1. Read operator's manual. 2. Check that hitch & coupler device are rated equal to or greater than trailer gross weight rating. 3. Check hitch & coupling device for worn or defective parts, ensure that coupling device is secure to vehicle. 4. Check tires for tread wear & inflation. 5. Connect safety chains using cross pattern, connect breakdown chain to bumper or hitch. 6. Test brakes on both vehicles, check trailer lights for proper operation. 7. Inspect & grease bearings every 1000 miles or once per year. <p>CAUTION: Trailer to be level when towing. Max.towing speed 55 M.P.H.</p>	<p>TOWING INSTRUCTIONS Before dragging, please read the instructions carefully to avoid accidents.</p>		
<p>17</p>  <p>DANGER Limbs can snag clothing. Rollers or blades can grab and pull you in faster than you can let go of limb. Cutting injury or death will result.</p> <p>Feed material only from side of table. Feed base of limb first.</p> <p>Never climb onto feed table. Use wood object to push short material.</p> <p>Gloves must have narrow cuffs.</p> <p>Keep away from rotating feed rollers and blades.</p>	<p>Clothing can get snagged on limbs. Rollers or blades can grab and pull you inwards faster than you can let go of your limb. Cutting injuries or death may occur.</p>		
<p>18</p>  <p>PUSH BAR TO STOP FEED</p>	<p>Push bar to stop feed.</p>	<p>19</p> 	<p>Reverse Feed, Stop Feed, Forward Feed</p>

GENERAL SAFETY

Accidents typically occur due to mistakes, lack of training, and failure to follow instructions. It is essential that all users are properly protected with the appropriate personal protective equipment and receive thorough training. All users must fully understand the content of this manual and the instructions they need to follow when operating this machine.

All safety designs have been implemented to safeguard users from all potential injuries during operation and reduce the risk of accidents. The general safety instructions listed in this document must be adhered to. Disregarding them could lead to serious injuries, fires, explosions, or even fatalities.

Regarding operator safety, operators should undergo comprehensive training and know the correct way to operate. Continuously memorizing all instructions and repeatedly reading labels are extremely beneficial.

WORKSITE SAFETY

- Operating this wood chipper requires at least two adults. This is an absolute requirement.
- Remove all irrelevant debris from the work site.
- The machine should be located in a safe, open area with good ventilation.
- All bystanders must stay away from the work site, which should be marked with a warning ribbon.

PERSONAL SAFETY

At no time should children be allowed to operate this machine. Ensure that children, pets, and individuals not using the equipment remain outside the work area. Stay vigilant and turn off the unit immediately if anyone enters the work zone. Children must be under the attentive supervision of a responsible adult at all times.

Do not attempt to operate the machine if you are under the influence of drugs, alcohol, or any medication that might impair your ability to use it correctly.

Dress appropriately for the task. Wear thick, long - legged pants, boots, and gloves. Avoid wearing loose - fitting clothing, shorts, or any type of jewelry. Fasten long hair so that it is above shoulder length. Keep your hair, clothing, and gloves clear of the moving parts. Loose items such as clothes, jewelry, or long hair can get caught in the moving components.

Protect your eyes, face, and head from any objects that the unit might project. Always wear safety goggles or safety glasses with side shields while operating the machine.

Wear suitable hearing protection. During the machine's operation, it is imperative to keep your hands and feet at a safe distance from all moving parts. These moving parts have the potential to cut or crush body extremities. Additionally, always ensure that your hands and feet are clear of any pinch points.

Avoid touching parts that may have become hot due to the machine's operation. Before attempting any maintenance, adjustment, or servicing, allow these parts sufficient time to cool down.

While operating the machine, remain alert, pay close attention to what you are doing, and apply common - sense principles. Do not overreach as this can lead to loss of balance and potential injury.

Do not operate the machine if you are barefoot, wearing sandals, or other types of lightweight footwear. Instead, wear protective footwear. Such footwear not only safeguards your feet but also enhances your grip on slippery surfaces. At all times, maintain proper footing and balance. This will enable you to better control the machine in the event of unexpected circumstances.

INSPECT YOUR MACHINE

Before starting the machine, conduct a thorough check. Ensure that all guards are in their proper positions and are functioning correctly. Verify that all nuts, bolts, and similar fasteners are securely tightened.

Under no circumstances should you operate the machine if it requires repair or is in a poor mechanical state. Replace any damaged, missing, or malfunctioning parts prior to use. Also, inspect for fuel leaks. It is crucial to keep the machine in a safe working condition at all times.

Do not use the machine if the engine switch fails to turn the machine on or off. Any gasoline-powered machine with an engine switch that fails to turn the machine on or off poses a significant danger. A faulty switch must be replaced.

Regularly verify that keys and adjusting wrenches are removed from the vicinity of the machine before starting it. A wrench or key left attached to a rotating part of the machine can cause serious personal injury.

Take measures to avoid accidental starting. Before transporting the machine or performing any maintenance or servicing on it, make certain that the engine switch is in the off position. Transporting or working on a machine with the switch on significantly increases the risk of accidents.

If the machine begins to vibrate abnormally, immediately stop the engine (motor) and check for the cause. Abnormal vibration is typically a warning sign of an underlying problem.

FUEL SAFETY

Fuel is extremely flammable, and its vapors have the potential to explode upon ignition. It is essential to take appropriate precautions when handling fuel to minimize the risk of severe personal injury.

When refilling or draining the fuel tank, use only an approved fuel storage container and perform the task in a clean, well-ventilated outdoor location. Under no circumstances should you smoke, or permit sparks, open flames, or any other ignition sources to be present in the vicinity while adding fuel or operating the machine.

Never fill the fuel tank indoors. Keep grounded conductive objects like tools away from exposed, live electrical components and connections to prevent sparking or arcing, as these phenomena could ignite fuel fumes or vapors.

Always shut off the engine and allow it to cool down completely before refilling the fuel tank. Never remove the fuel tank cap or add fuel when the engine is running or still hot. Do not operate the machine if there are known leaks in the fuel system.

Loosen the fuel tank cap slowly to release any pressure within the tank. Do not overfill the fuel tank; fill it to a level no higher than 1/2" below the bottom of the filler neck to accommodate fuel expansion caused by the heat of the engine.

Avoid creating any potential ignition sources for spilled fuel. If fuel is spilled, do not try to start the engine. Instead, move the machine away from the spill area and refrain from creating any ignition sources until the fuel vapors have completely dissipated.

If fuel comes into contact with your skin or clothes, wash your skin immediately and change your clothes. Store fuel only in containers that are specifically designed and approved for this purpose.

Store fuel in a cool, well-ventilated area, keeping it safely away from sparks, open flames, or other ignition sources. Never store fuel or a machine with fuel in the tank inside a building where fuel fumes could reach a spark, open flame, or any other ignition source, such as a water heater, furnace, or clothes dryer. Allow the engine to cool down before storing the machine in any enclosed space.

FEEDING MATERIALS

When using the machine, it is crucial to adhere to the following material - feeding guidelines for optimal performance and longevity.

Only feed clean materials into the machine. Foreign substances like soil, sand, grit, stones, and metal pieces can severely damage the sharp edges of the cutting knives. Additionally, root balls and dead wood will rapidly dull the blades.

Steer clear of feeding pine needles, flax, and cabbage tree leaves into the machine. These stringy materials have a tendency to wrap around the rotor shaft and gradually work their way into the bearing, causing potential mechanical issues.

Avoid inserting short, stubby pieces of wood into the machine. Such pieces often bounce and spin erratically within the feed hopper. Instead, combine these short pieces with longer ones before feeding. Once you've become acquainted with the machine's capabilities, prune materials to match its requirements.

This machine is designed to be self-feeding. Under no circumstances should you force branches into the blades. Let the machine automatically draw in the materials. Before adding the next batch of branches, allow sufficient time for the machine to reach its maximum spinning revolutions. This ensures efficient operation and reduces the risk of jams or damage to the equipment.

GENERAL SAFETY MATTERS

- Always stop the chipper engine before making any adjustments, refuelling or cleaning.
- Always check the rotor has stopped rotating and remove the chipper ignition key before maintenance of any kind, or whenever the machine is to be left unattended. If in doubt, look through the in-feed funnel to see if rotor is still moving.
- Always check the machine is well supported and cannot move. If working on an incline, position on solid ground, across the slope.
- Always operate the chipper with the engine set to maximum speed when chipping.
- Always check (visually) for fluid leaks. If found, resolve the leak before operating the chipper.
- Always take regular breaks. Wearing personal protective equipment for long periods can be tiring and hot.
- Always keep hands, feet and clothing out of feed opening, discharge and moving parts.
- Always use a push stick to push in short pieces. Under no circumstances should you reach into the funnel.
- Always keep the operating area clear of people, animals and children.
- Always keep the operating area clear from debris build up.
- Always keep clear of the chip discharge tube. Foreign objects may be ejected with great force.
- Always ensure protective guarding is in place before commencing work. Failure to do so may result in personal injury or loss of life.
- Always operate the chipper in a well ventilated area - exhaust fumes are dangerous.
- Ensure a fire extinguisher is available on site.
- Ensure a personal first aid kit and hand cleaning materials are available (e.g. waterless skin cleanser).
- Always cover ignition switch with plug provided when towing or jet wash cleaning.

MOVING SAFETY

This wood chipper is equipped with a Tow Bar with a 2-inch Coupler. However, never attempt to tow the machine on public highways, roads, or arterial roads. Towing this equipment on these public routes not only violates the traffic regulations in most regions but also poses a serious safety risk.

MACHINE USE AND CARE

Position the machine in such a way that it cannot move during maintenance, cleaning, adjustment, assembly of accessories or spare parts, as well as under storage.

Do not force the machine. Use the correct machine for your application. The correct machine will do the job better and safer at the rate for which it is designed.

Do not change the engine governor settings or over-speed the engine. The governor controls the maximum safe operating speed of the engine.

Do not run the engine at a high speed when you are not working.

Do not put hands or feet near rotating parts.

This machine has two rotating cutting knives capable of amputating hands and feet and throwing objects. Keep hands and feet out of openings while machine is running. Failure to observe these safety instructions could result in serious injury or death.

Avoid contact with hot fuel, oil, exhaust fumes and hot surfaces. Do not touch the engine or muffler. These parts get extremely hot from operation. They remain hot for a short time after you turn off the unit. Allow the engine to cool before doing maintenance or making adjustments.

If the machine should start to make an unusual noise or vibration, immediately shut off the engine, disconnect the spark plug wire, and check for the cause. Unusual noise or vibration is generally a warning of trouble.

Use only attachments and accessories approved by the manufacturer. Failure to do so can result in personal injury.

Keep the engine and muffler free of grass, leaves, excessive grease or carbon build up to reduce the chance of a fire hazard.

Never douse or squirt the unit with water or any other liquid. Keep handles dry, clean and free from debris. Clean after each use.

Observe proper disposal laws and regulations for gas, oil, etc. to protect the environment.

When storing machine out of the reach of children and do not allow persons unfamiliar with the machine or these instructions to operate it. This machine can be dangerous when used by an untrained user.

MAINTAINING SAFETY

Some parts of this machine are made of plastic or rubber and should be kept away from any chemicals. Always remember never to cover the machine while the muffler is still hot. Do not alter or adjust any part of the chipper shredder or its engine that are sealed by the manufacturer or distributor. Only a qualified service technician may adjust parts that increase or decrease governed engine speed. To maintain your machine, check for any misalignment or binding of any moving parts. Parts that are broken or worn down may affect the machine's operation. If damaged or worn parts are identified, they should be repaired before use. Many accidents are caused by poorly maintained equipment.

BASIC WOOD CHIPPING SAFETY

The operator should be aware of the following points:

- Maintain a safety exclusion zone around the chipper of at least 10 meters (approximately 33 feet) for the general public or employees without adequate protection. Use hazard tape to identify this working area and keep it clear from debris build up. Chips should be ejected away from any area the general public have access to.
- Hazardous material - Some species of trees and bushes are poisonous. The chipping action can produce vapour, spray and dust that can irritate the skin. This may lead to respiratory problems or even cause serious poisoning. Check the material to be chipped before you start. Avoid confined spaces and use a face mask if necessary.
- Be aware when the chipper is processing material that is an awkward shape. The material can move from side to side in the funnel with great force. If the material extends beyond the funnel, the brush may push you to one side causing danger. Badly twisted brush should be trimmed before being chipped to avoid thrashing in the feed funnel.
- Be aware that the chipper can eject chips out of the feed funnel with considerable force. Always wear full head and face protection.
- Always work on the side of the machine furthest from any local danger, e.g., not the road side.
- Never leave the chipper unattended when running. Machines must be supervised at all times when in use.
- In the event of an accident, stop the machine, remove the key and call the emergency services immediately.

Danger: Keep the discharge chute clear of all personnel during wood chipping.

OPERATE ZONE

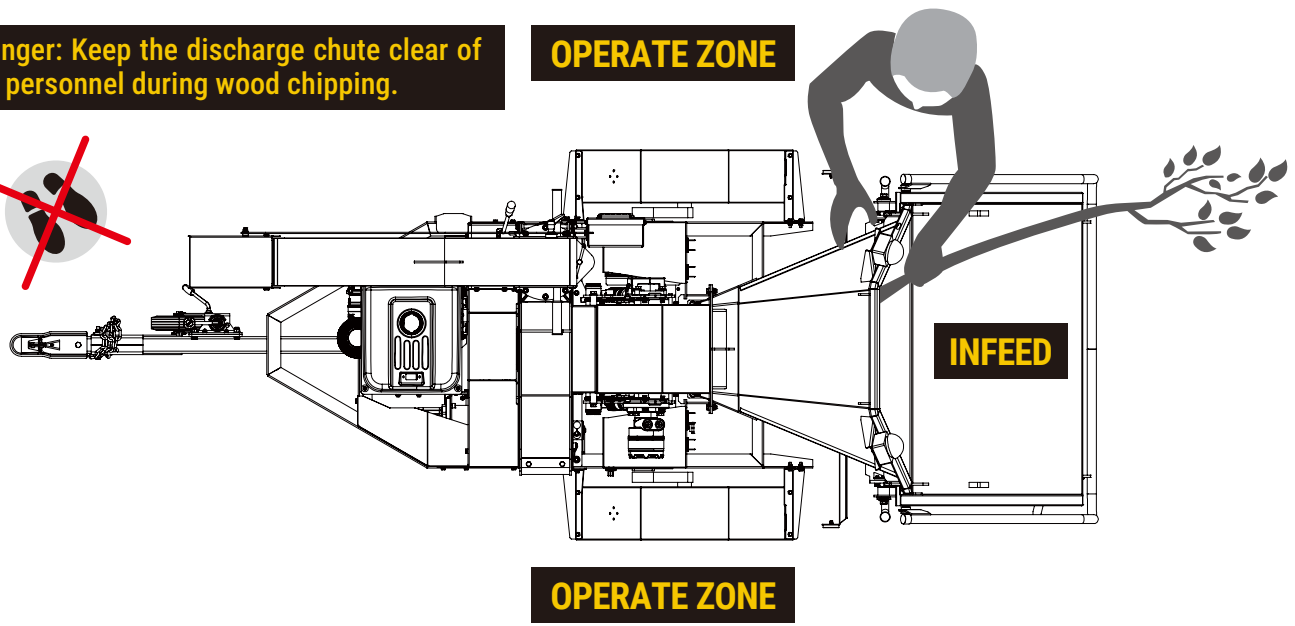

OPERATE ZONE

BATTERY SAFETY

 **Burn Hazard!** The battery electrolyte is highly corrosive and poisonous. Any contact with the eyes, skin, or clothing can cause severe burns and other grave personal injuries. In case of contact, seek immediate medical assistance without delay. Exercise extreme caution when handling batteries to prevent electrolyte leakage and potential exposure.

- Wear gloves and safety glasses or a face shield when working on or near batteries.
- Use a battery carrier to lift the battery or place hands at opposite corners to avoid spilling acid through the vents.
- Avoid contact with battery electrolytes:
 - External Contact: Flush immediately with water.
 - Eye Contact: Flush with water for 15 minutes. Get prompt medical attention. Clean up any spilled electrolyte immediately.
 - Avoid contact with battery posts, terminals and related accessories. They contain lead and lead compound chemicals known to cause harm if ingested. Wash hands immediately after handling battery.
 - Keep all sparks and flames away from batteries. Electrolyte fumes are explosive.
 - To avoid injury from spark or short circuit, disconnect battery ground cable before servicing any part of the electrical system.

 **Risk of explosion or fire!** Do not let metal objects come into contact with the battery terminals. Arcing can cause a fire or explosion. Cover terminals if working near batteries.

- Do not jump-start or charge a frozen battery. Frozen batteries can explode and result in death or serious injury. Let the battery thaw before charging.

HYDRAULIC SAFETY

- Ensure all components in the hydraulic system are clean and well-maintained.
- Before pressurizing the system, verify that all fittings are secure and that lines, hoses, and couplings are free from damage.
- Do not attempt temporary or makeshift repairs on hydraulic lines, fittings, or hoses using tape, clamps, or adhesives. Hydraulic systems operate under extremely high pressure, and such repairs can suddenly fail, posing serious safety hazards.
- Always wear appropriate hand and eye protection when inspecting for high-pressure leaks. Use a piece of wood or cardboard—never your hands—to help detect and isolate the source of a leak safely.
- If you are injured by a high-pressure stream of hydraulic fluid, seek immediate medical attention. Even small punctures can lead to serious infections or toxic reactions.
- Always relieve system pressure before performing any maintenance or repair work.

CONTENTS SUPPLIED

Your Wood chipper comes partially assembled and contains the following:

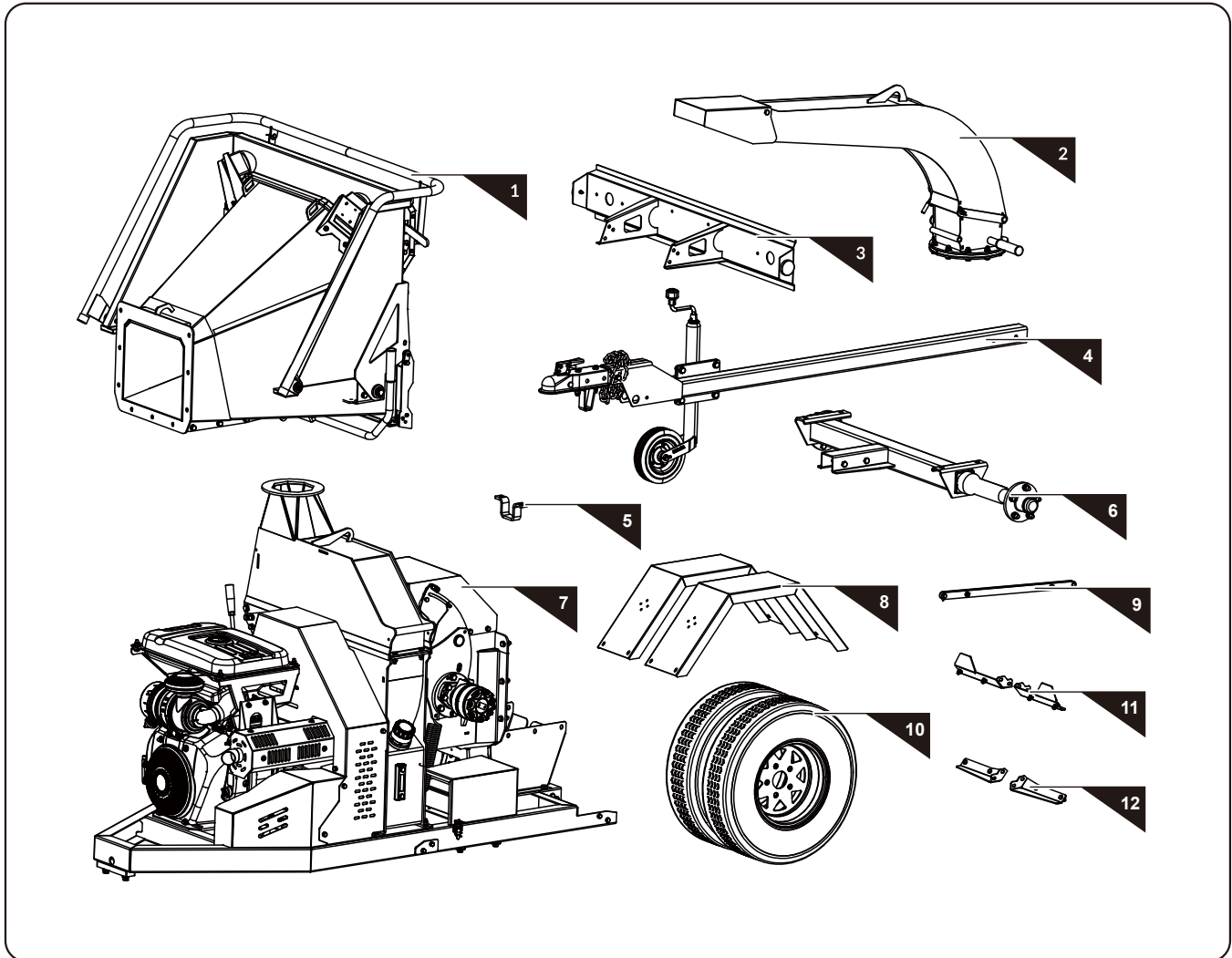

- | | |
|-----------------------------|--------------------------|
| 1. In-feeding chute | 7. Engine and base frame |
| 2. Lower discharging chute | 8. Fender |
| 3. Taillight holder | 9. Connecting rod |
| 4. Tow Bar and Jockey Wheel | 10. Wheels |
| 5. Reinforced | 11. Fender assembly |
| 6. Axle | 12. Fender assembly |

ASSEMBLY

Following the assembly directions below, you will assemble the machine in a few minutes.

AXLE

Install the axle onto the base frame and secure it using M12×30 full-thread hex head bolts, 12 mm spring washers, and 12 mm flat washers.

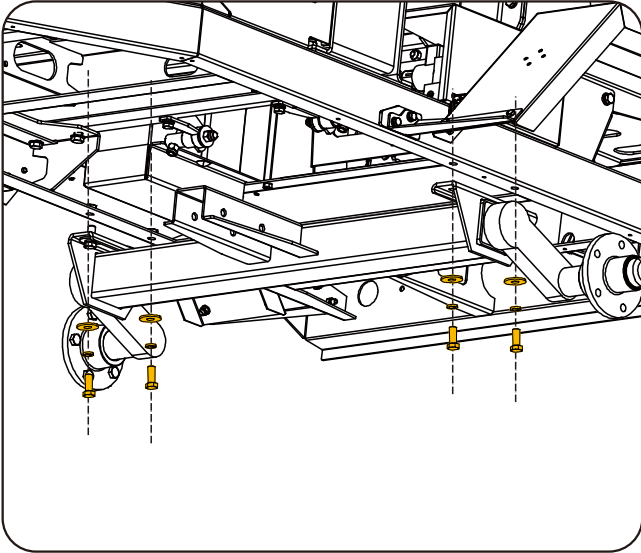

Next, attach the tow bar and jockey wheel to the base frame using M12×90 hex head bolts, M12 hex lock nuts, and 12 mm flat washers.

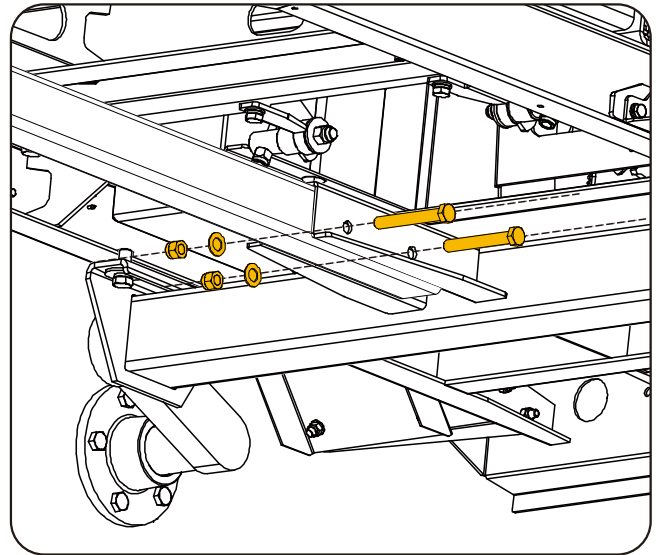

TOW BAR AND JOCKEY WHEEL

Begin by securing the tow bar and jockey wheel using the tow bar clamp. Use M12×35 full-thread hex head bolts, along with 12 mm flat washers and 12 mm spring washers.

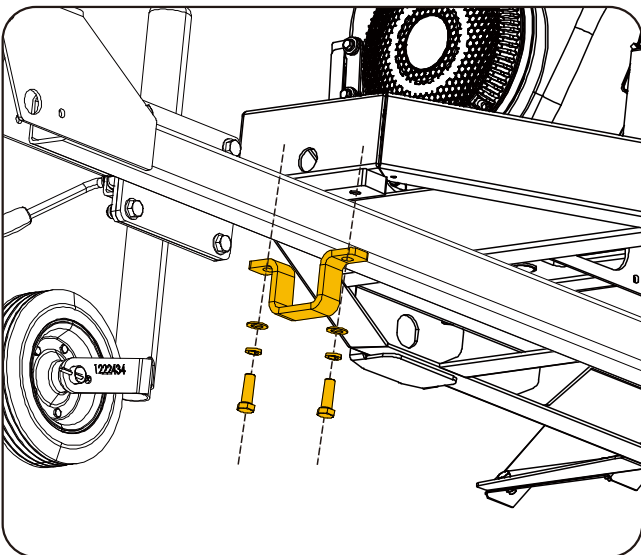

WHEELS

Assemble the wheel onto the axle.

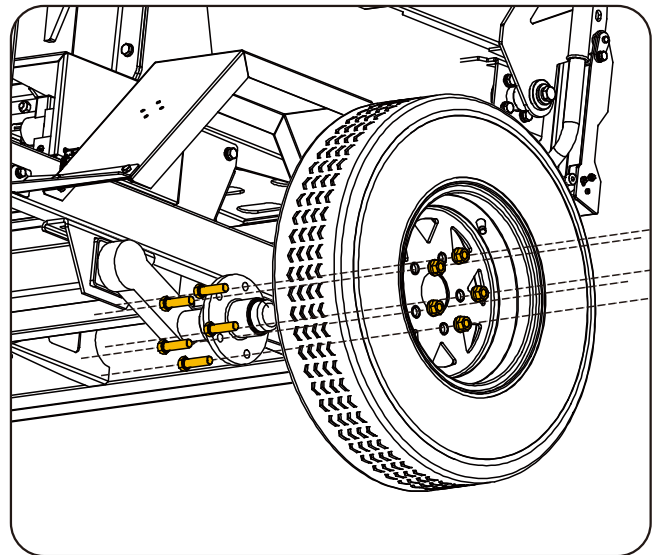

LOWER DISCHARGING CHUTE

Use M10×40 full-thread bolts, M10 hex jam nuts, and 10 mm flat washers to assemble the lower discharging chute to the base frame.

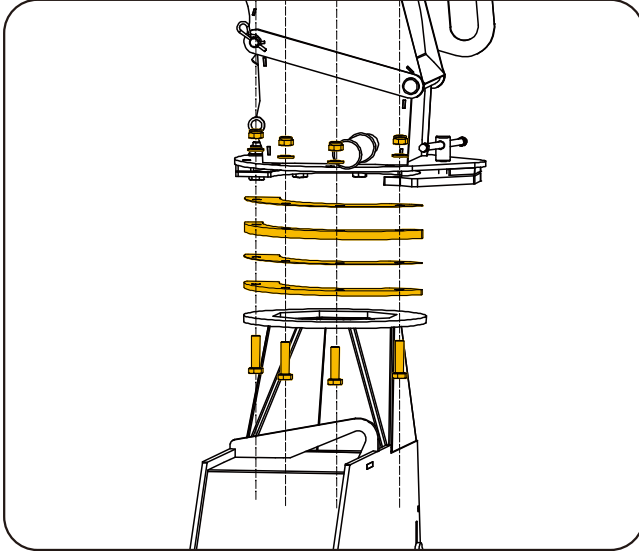

IN-FEEDING CHUTE

Assemble the in-feeding chute to the base frame using a thin hexagon lock nut M10, a full - thread hexagon - head bolt M10×30, a plain washer Class C 10 and a spring washer 10.

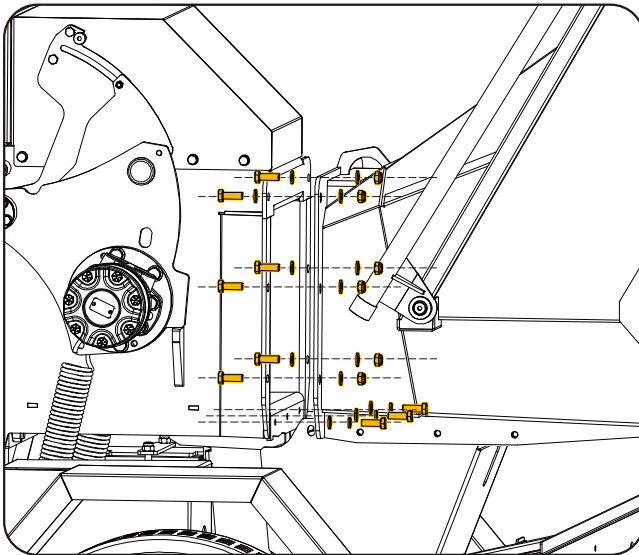

Then use a full - thread hexagon - head bolt M10×25, a spring washer 10 and a plain washer Class C 10 for fixation.

Fix both ends of the connecting rod to the positions shown in the figure using a pin of Type B 8×26, a plain washer 8 and a split pin 2×20.

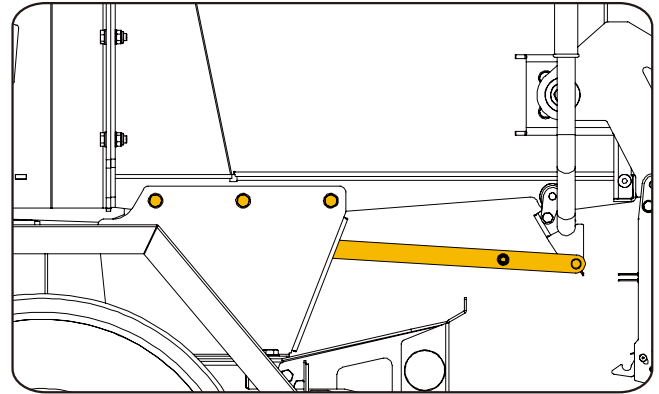

FENDER

Assemble the fender to the base frame through the fender assembly using an M8×20 full-thread hexagon head bolt, M8 hex lock nut, and Ø8 plain washer.

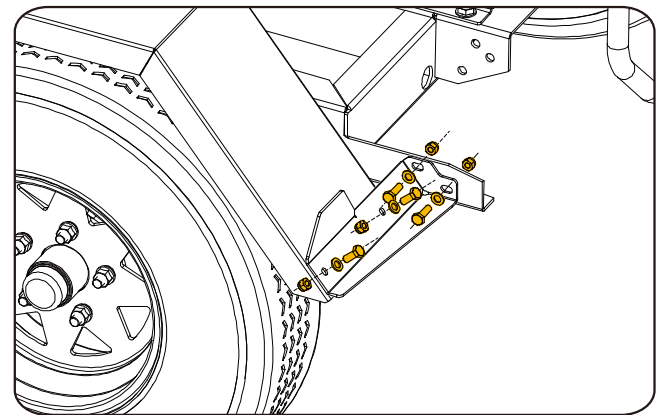

TAILLIGHT HOLDER

Use a full-thread M10×25 hexagon head bolt, a Class C M10 plain washer, and an M10 hexagon lock nut to assemble the taillight holder to the base frame.

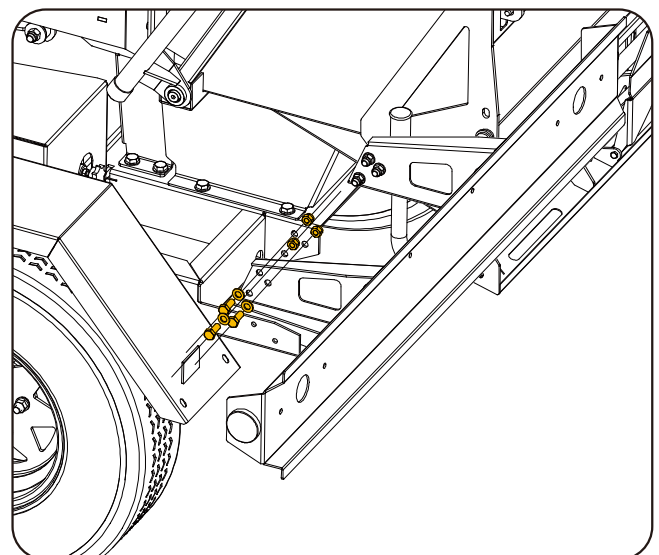

KNOW YOUR MACHINE

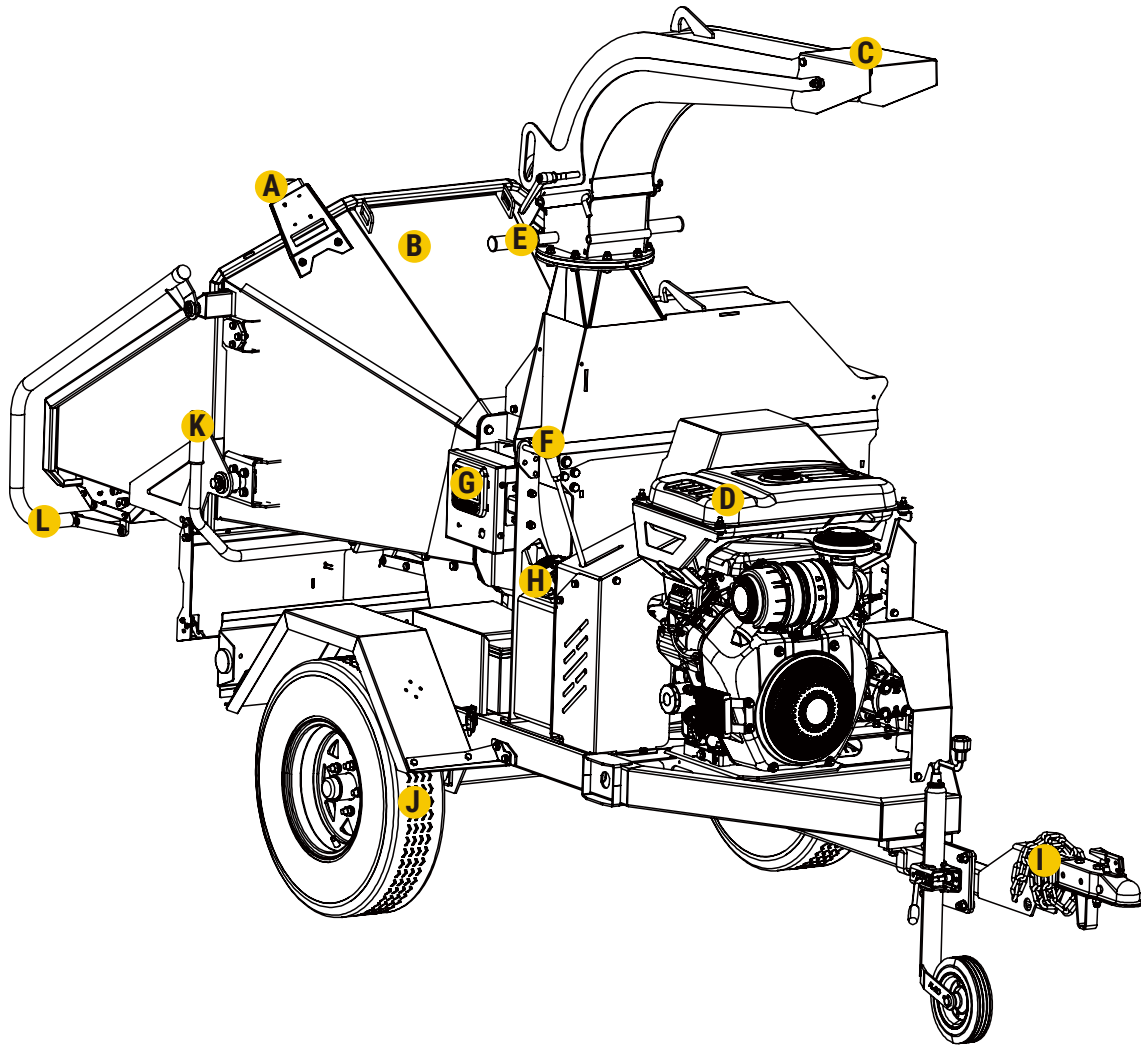

A EMERGENCY STOP

B FEED CHUTE

C DEFLECTOR

D ENGINE

E DIRECTION HANDLE

F BELT CLUTCH HANDLE

G CONTROL PANEL

H HYDRAULIC RETURN PORT

I TOW COUPLER

J WHEEL

K FEED ROLLER REVERSING LEVER

L FEED CONTROL LEVER

EMERGENCY STOP

In case of an emergency, press the emergency stop button to immediately halt the machine, including the engine.

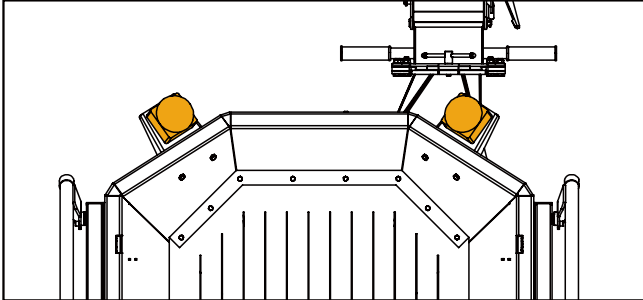
**BELT CLUTCH HANDLE**

After starting the engine, pull the belt clutch lever to the position shown in the figure.

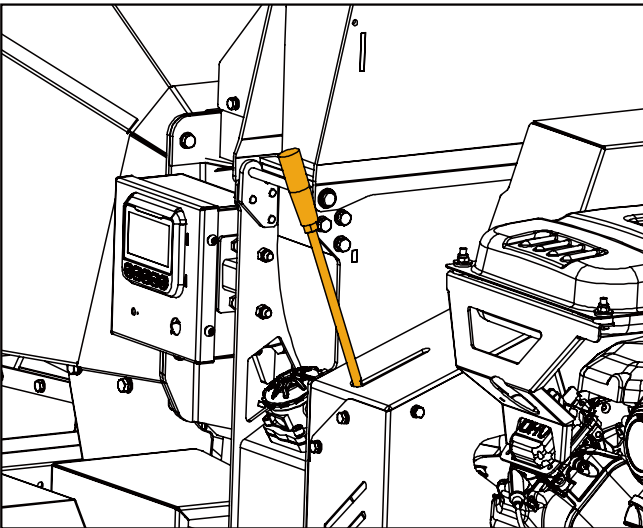
**FEED CONTROL LEVER**

When the feed control lever is pressed, feeding stops. Pulling it up resumes feeding.

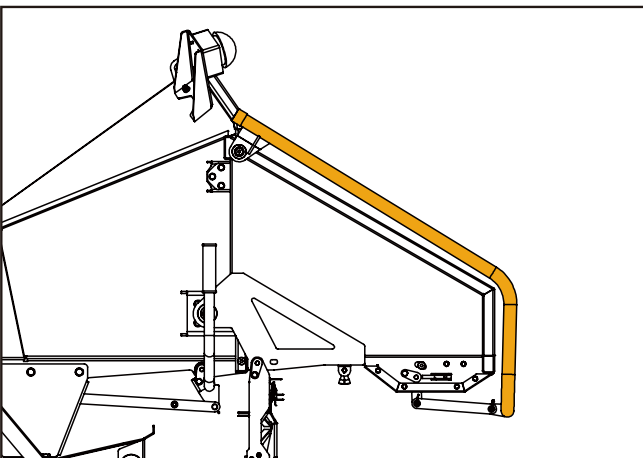
**FEED ROLLER REVERSING LEVER**

The control lever has three positions, as shown in the figure:

Left: The feed roller rotates in reverse to discharge material.

Center: Both feeding and reversing are stopped.

Right: The feed roller rotates forward to start feeding.

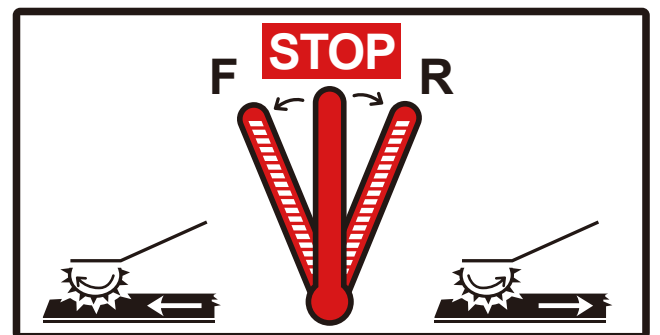
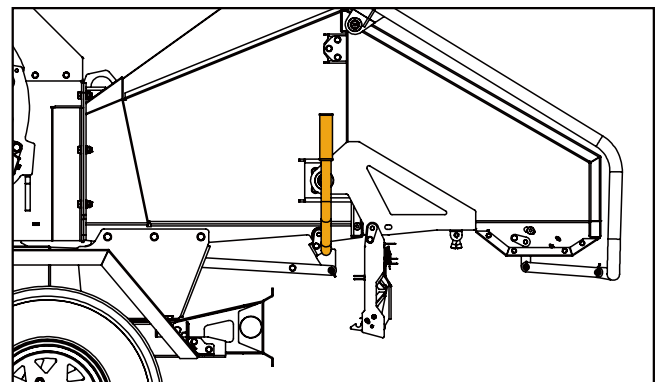
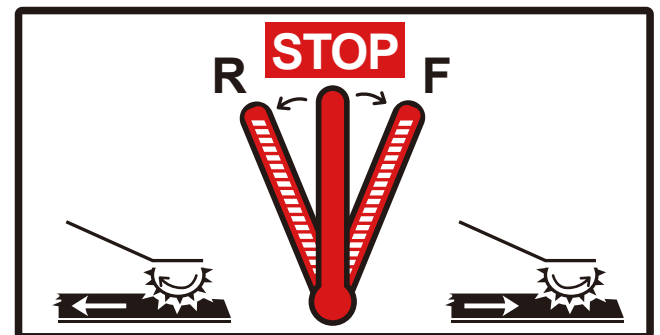
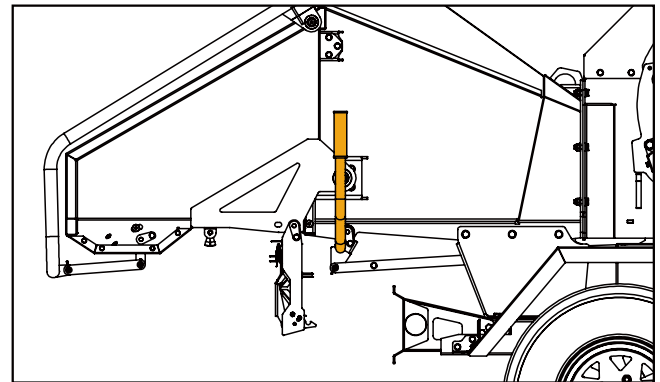

HYDRAULIC FLOW CONTROL VALVE

The flow control valve has 10 scale positions, marked 0 to 9.

- Turning the dial counterclockwise increases the number, allowing greater flow and resulting in faster feed roller speed.
- Turning it clockwise decreases the number, allowing less flow and resulting in slower feed roller speed.

The flow control valve adjusts the speed of the hydraulic motor that drives the feed rollers.

- When processing larger-diameter branches, reduce the flow as needed.
- When processing smaller-diameter branches, increase the flow to raise the feed speed.

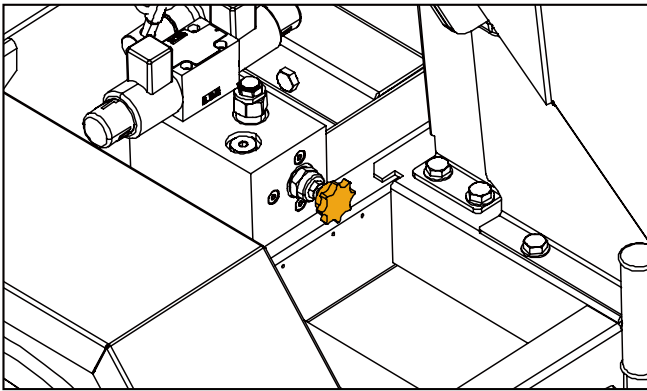

CONTROL PANEL

Display Parameters

- Display Size: 4.3-inch true color screen.
- Resolution: 800 × 480 pixels.

The main interface primarily displays key information such as alarm icons, analog gauges, text-based alarm messages, operating status, and total working time. Details are as follows:

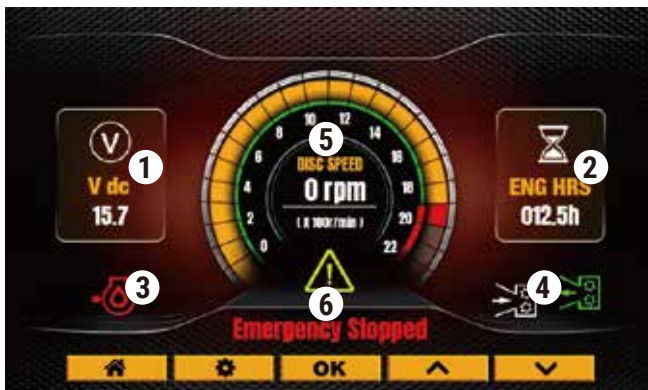

1. Battery Voltage (Charging Status)

2. Engine Working Hours

3. Engine Oil Pressure Alarm

4. Feed / Reverse Status Indicator

5. Chipper Disc Speed Display

6. Alarm Message Prompt:

- Example: Emergency stop is activated. Engine cannot start. Please release the emergency stop button.

Button Function Area:

Indicates the function of each button based on the current screen. The functions are as follows:

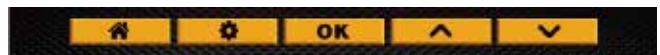

- Home
- Settings
- Confirm
- Up (Increase)
- Down (Decrease)

System Settings Interface

Press the Settings button  on the main screen to enter the settings interface.



High Speed: Sets the automatic feed start speed.
Default: 1750 rpm

Low Speed: Sets the automatic feed stop speed.
Default: 1500 rpm

Cal.: Calibration parameter for the speed sensor.
Default: 8

Back Time: Set reverse feed time. Default: 0 seconds

Reserved Blank: Reserved space for future use

Restore Defaults: Reset parameters to factory default values

OPERATING INSTRUCTIONS

PREPARATION

All personnel involved with this machine must thoroughly read and fully understand the contents of this manual. Prior to use, training is essential and should be provided by the dealer. The dealer must also possess a comprehensive understanding of the manual, including proper operation, maintenance, and all aspects related to the machine's functions and safety protocols.

Work Site Preparation:

- Remove all rocks, metal objects, or other materials that could damage the machine from the work area and material storage zones.
- Clear all obstacles that may block walkways or access paths.
- Ensure the work site is not located under high-voltage power cables.
- Verify the work site is well-lit and adequately ventilated.
- Confirm the work site is in an open area with sufficient space for operation and movement.
- Identify where branches/twigs will be processed and designate a collection area for wood chips.
- Maintain enough space for material delivery and unobstructed access.
- Check that first aid kits are fully stocked, in good condition, and readily accessible.
- Ensure at least two adult operators are present during machine operation to monitor functionality and maintain site safety.

Material Preparation:

Proper material preparation enhances efficiency, improves working conditions, and reduces the risk of unnecessary maintenance costs.



Metals, rocks, glass, or similar substances can severely damage the machine, leading to property loss, injuries, or even fatalities. Vines or entanglement wrapping around twigs may entangle operators or damage the machine, so all vines in the material must be removed beforehand.

- An inclined feeding end facilitates easier material loading.
- Ensure materials are sufficiently long (over 1.2m) to keep hands clear of the rollers. Short materials can be pushed into the rollers using longer pieces as a guide.
- Adjusting material weight and length by cutting them into appropriate pieces can reduce the risk of operator injury.
- This chipper is designed for processing branches free of foreign objects such as rocks, metals, mud, or any substances that could damage the machine.

Chipper Preparation:

To secure the machine on-site, one of the following methods must be used:

- Proper towing and anchoring to prevent unintended movement; or
- Deployment of support wheels with wheel chocks (blocks) firmly in place to stabilize the unit.

Note: Operating the chipper on uneven, sloped, or unstable ground can result in equipment instability and poses serious safety risks.

While Towing:

When towing the chipper, follow these safety precautions to ensure secure transportation:

- Ensure the towing vehicle is powerful enough to handle the chipper's weight.
- Always park the vehicle on flat, level ground before connecting or disconnecting the chipper.
- The towing vehicle must be fully stopped with the parking brake engaged.
- Never operate the chipper while it is being transported.
- Ensure the tow coupler is securely fixed onto the vehicle's tow ball.
- Attach the safety chain and cable:
 - The chain must be evenly hooked and must not drag on the ground.
 - The cable must be correctly connected.
- Check that all trailer lights (brake, indicator, etc.) are functioning properly.

When Parking Without Towing:

- Each model is equipped with a jacky wheel for support when parked without being towed. Always retract the jacky wheel during transportation.
- Ensure the chipper's chassis remains parallel to the ground.
- Place wheel blockers in position to secure the wheels.

ADD OIL TO ENGINE

*Shipped with NO fluids. Must add own fluid



The engine is shipped without oil. Do not start the engine before adding oil.

1. Make sure the chipper shredder is on a flat, level surface.
2. Remove the oil fill cap/ dipstick to add oil.
3. Remove the dipstick and check the oil filling volume which should be at the upper limit of the scale (F point).



DO NOT OVERFILL. Check engine oil level daily and add as needed.

4. Completely insert the dipstick into the dipstick hole during inspection.
5. Dispose of used oil at an approved waste management facility.

Engine oil

SAE 10W-30 is recommended for general, all-temperature use. Other viscosities shown in the chart may be used when the average temperature in your area is within the indicated range. (See engine manual for oil capacity, oil recommendation, and location of fill cap.).

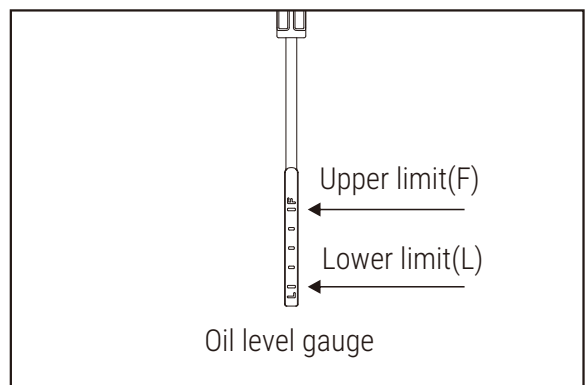
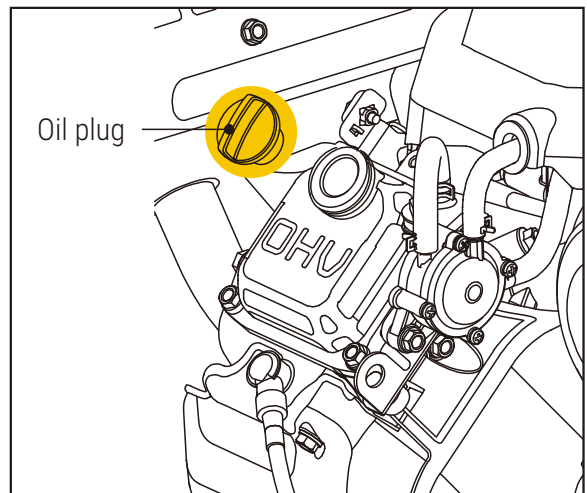

ENGINE FUEL

*Shipped with NO fluids. Must add own fluid

With the engine stopped, check the fuel level gauge. Refill the fuel tank if necessary.



Pressure can build up in the fuel tank. Allow the engine to cool for at least two minutes before removing fuel cap. Loosen the fuel cap slowly to relieve any pressure in the tank.

Use clean, fresh, regular unleaded gasoline. DO NOT mix oil with gasoline. Be sure not to fill above the upper limit mark. Always allow room for fuel expansion.

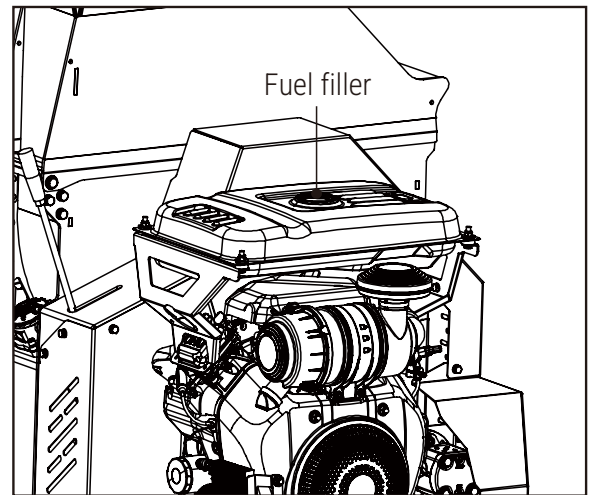

Do not fill the fuel tank above the upper limit. Over fill will result in engine die or damage the carbon canister (if equipped) and void your warranty.

FIRE OR EXPLOSION

Gasoline is highly flammable and extremely explosive.

Fire or explosion can cause severe burns or death.

Keep flammable items away while handling gasoline.



Fill fuel tank outdoors and in a well-ventilated area with the engine stopped.

Always wipe off spilled fuel and wait until the fuel has dried before starting the engine.

DO NOT operate the engine with known leaks in the fuel system.

Use proper fuel storage and handling procedures. DO NOT store fuel or other flammable materials nearby.

Empty the fuel tank before storing or transporting this engine.

Keep fire extinguisher handy and be prepared if a fire starts.

NEVER use engine or carburetor cleaner products in the fuel tank or permanent damage may occur.

HYDRAULIC OIL

***Shipped with NO fluids. Must add own fluid**



USE PLASTIC GLOVES TO KEEP OIL OFF SKIN AND DISPOSE OF THE USED OIL AND FILTER IN AN ECOLOGICALLY SOUND WAY. THE OIL AND FILTER SHOULD BE CHANGED ONCE A YEAR OR AT ANY TIME IT BECOMES CONTAMINATED. BEFORE STARTING CHECK THAT THE CHIPPER IS STANDING LEVEL AND BRUSH AWAY LOOSE CHIPS.

1. Remove the black screw cap from the top of the filter housing.
2. Partially remove filter element from inner cup. Leave filter to drain for 15 minutes.
3. Remove filter element from cup when clear of hydraulic oil.
4. Remove drain plug and drain oil into a suitable container.
5. Replace drain plug.
6. Refill with ISO VG 46 hydraulic oil until the level is between the min and max lines on the tank (about 15 litres).
7. Refit the filter cup, install a new filter element and refit the black screw cap, to the filter housing, ensuring o-ring remains in place.

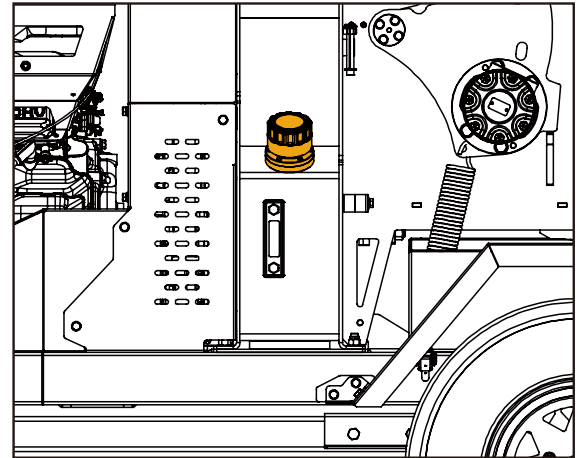

STARTING ENGINE

1. Open the fuel valve (fuel pipe switch) under the fuel tank.

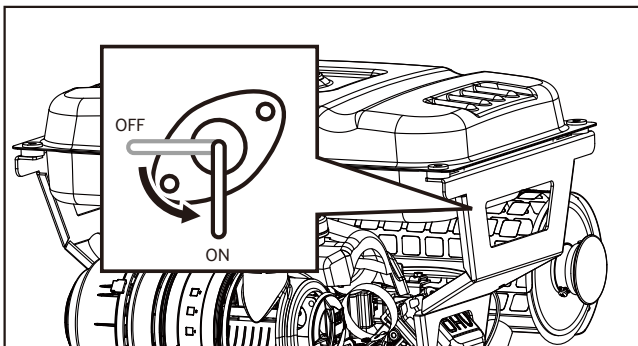

2. Move the throttle slightly.

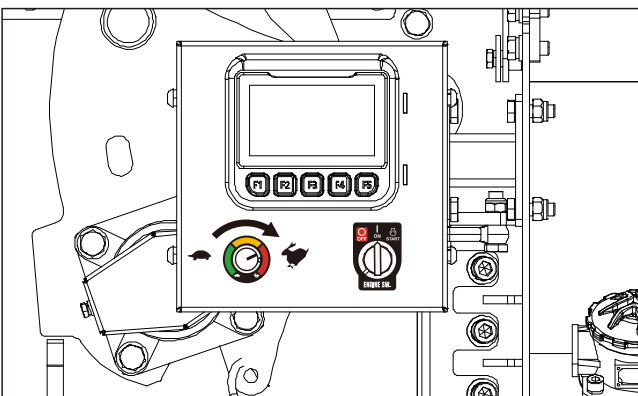

3. Move the engine switch to the ON position.

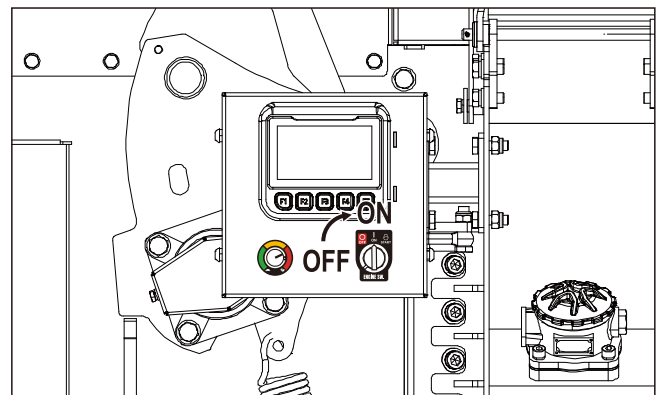

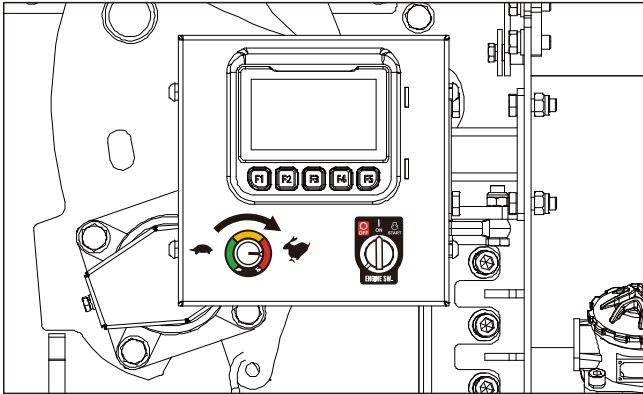

When starting the machine for the first time, you need to start it several times when starting the key.

4. Move the throttle lever slightly to the FAST speed.



STOP ENGINE

To stop the engine in an emergency, simply turn the engine switch to the OFF position. Under normal conditions, use the following procedure:

1. Move the throttle lever to the SLOW () position.
2. Let the engine idle for one or two minutes.
3. Turn the engine switch to the OFF position.
4. Turn the fuel valve lever to the OFF () position.



Sudden stopping at a high speed under a heavy load is not recommended. Engine damage may result.



Do not move the choke control to CLOSE to stop the engine. Backfire or engine damage may occur.

Wait until the machine completely stops. Allow the engine to completely cool. Then clean out the interior of the machine and its discharge chute.



Do not disengage the belt drive with the machine running. This will cause friction and vibration on the belt drive.

TRANSPORTATION

- The maximum legal towing speed is 60 mph (96 km/h).

Reduce speed on rough or uneven surfaces to minimize excessive vibration and protect the machine.

- Avoid obstacles that may contact or damage the underside of the machine.
- Steer clear of steep gradients and heavily potholed terrain.
- Exercise extra caution when reversing—the short wheelbase causes the machine to respond quickly to steering inputs.
- Tire pressure should be maintained at 2.8 Bar (41 psi).
Ensure all wheel nuts are tightened to between 90 Nm and 100 Nm.
- Before departure:
 - Remove all loose woodchip material from the machine.
 - Ensure the chute is securely fixed in the inboard (transport) position.
 - Confirm that the hopper tray is closed in the upright position and the locking latch is fully engaged.

ATTACHING TO THE VEHICLE TOW HITCH

Ensure the vehicle's tow ball is clean and well-greased. Turn the jockey wheel handle anticlockwise to raise the machine hitch until the hitch socket is positioned above the vehicle's tow ball.

Reverse the vehicle carefully so that the tow ball aligns directly beneath the machine's hitch socket. Grasp the handle on the tow head and push back the safety catch with your thumb.

Turn the jockey wheel handle clockwise to lower the hitch socket onto the tow ball. Release the tow head handle and continue winding the jockey wheel handle clockwise. The tow head should snap securely into place on the tow ball. If it does not, repeat the previous two steps to ensure proper alignment and connection.

Continue turning the jockey wheel handle until it is fully retracted and the jockey wheel frame is seated in its notch on the stem. The machine's full weight should now rest on the towing vehicle.

Release the jockey wheel clamp, slide the jockey wheel assembly fully upward, then tighten the clamp securely.

Connect the vehicle's trailer socket to the machine's socket using the connection lead. Verify that all machine and vehicle lights are functioning correctly.

The machine is now securely attached to the tow vehicle and ready for transport.

MAINTENANCE



ALWAYS IMMOBILISE THE MACHINE BY STOPPING THE ENGINE, REMOVING THE IGNITION KEY AND DISCONNECTING THE BATTERY BEFORE UNDERTAKING ANY MAINTENANCE WORK.

Item	How	Before start	8 hrs	40 hrs	120 hrs	400 hrs
Entire machine	Visual inspection	✓	✓			
	Clean machine		✓			
Tighten parts (excl. blade bolts)	Use thread fasten glue			✓		
Blades	Grinding or replacing blades while chips are not good		✓			
Blade bolts	Check bolts while checking blades, change if necessary		✓			
Gap between blade and anvil	Do adjustment to get right gap (1-1.5mm) between blade and anvil			✓		
Anvil	Check anvil while change blade, change if necessary			✓		
Belt	Check tension of belt and make it right. change if necessary.		✓	✓		
Roller	Roller worn or cracked should be changed immediately.	✓				
Oil return filter in Hydraulic oil tank	Change accordingly.					✓
Hydraulic oil	Check, replace, fill to 3/4 position if necessary.	✓				

SAFE MAINTENANCE

- ALWAYS STOP THE ENGINE, remove the ignition key, and disconnect the battery to immobilize the machine before starting any maintenance.
- Handle blades with extreme care to prevent injury. WEAR GLOVES when handling cutters or sharp components.
- Keep drive belts connected while changing blades to restrict sudden movement of the rotor and reduce accident risks.
- The machine's major components are heavy. USE PROPER LIFTING EQUIPMENT for disassembly to avoid physical strain or damage.
- CLEAN THE MACHINE REGULARLY—clean surfaces are safer and easier to inspect/service. Avoid direct contact with hydraulic oil; use protective gear if exposure is possible.

SPARES

You should only fit genuine replacement blades, screws and chipper spares. Failure to do so will result in the warranty being invalidated and may cause damage to the chipper, personal injury or even loss of life.

BATTERY MAINTENANCE

- Remove the negative lead first and then the positive lead.
- Clean, charge and/or top up the battery as required.
- Installation is the reverse of removal steps. Apply a smear of petroleum jelly to the terminals to prevent corrosion.

CHANGE BLADES

Check the disc blade sharpness daily.

If you're processing material containing a lot of sand, soil, or dirt, inspect the blades more frequently.

If the chipper is not pulling in material on its own or if material must be forced into the chipper, the disc blades are likely dull and need sharpening or replacement.



WARNING: Risk of fingers or hands being pinched or wedged between the lower disc hood and the disc. Rotate the disc slowly and always be aware of hand placement.

1. Shut off the engine and remove the key.
2. Remove the M10×35 bolts securing the guard, and open the guard.
3. Slowly rotate the cutting disc until the blade is visible from the hopper side.
4. Remove the bolts and nuts securing the blade.
5. Before reinstalling the blade, clean the back of the blade, the bolts, and the rotor mounting area.
 - Ensure no debris or material is present under the blade during reassembly.
 - If the blade is not flush and properly tightened, it will loosen quickly during operation.
6. Reassemble the blade, bolt, washer, and nut in the order shown in the diagram.
 - Use only genuine nuts and washers, as they are of a higher grade than typical stock fasteners.
 - Using incorrect or lower-grade fasteners may cause equipment damage, injury, or death.

Genuine blades and bolts are strongly recommended.

7. Apply anti-seize compound (copper-based) to the bolt threads and the back of the nut.

- Do not apply copper grease to the blade contact surface or the underside of the bolt head.

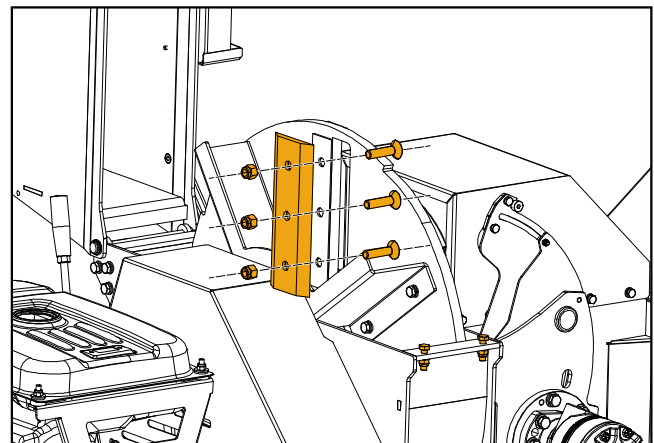

BELT

1. Remove the belt guard.
2. Push the clutch belt lever to the right to loosen the belt.
3. Remove the pulley guard.
4. Loosen the belt pressure plate.
5. Remove the old belt and replace it with a new one.
6. Push the clutch belt lever to the left to tighten the belt, then adjust the belt pressure plate so that it is 5–8 mm from the belt.
7. Reinstall the pulley guard and belt guard following the steps above.

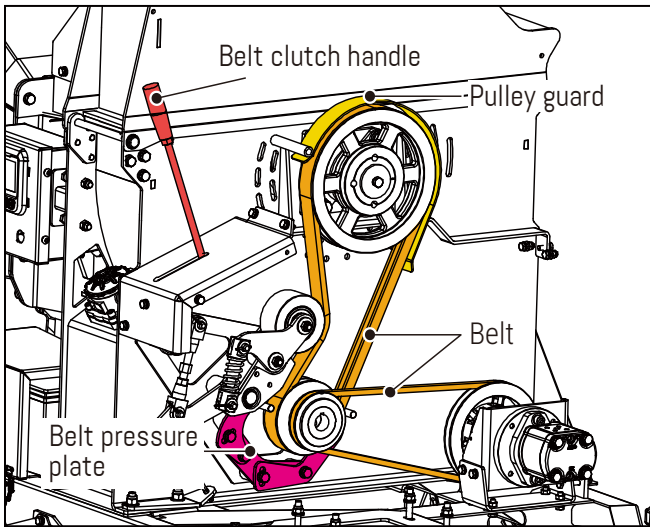

 Always replace both belts, as they come in a matched set. This is required for proper operation.

 **NOTE:** Check and re-tighten belts after initial break-in period, one hour of use.

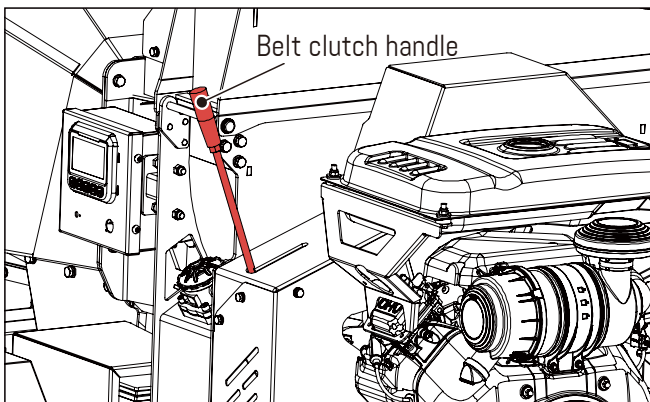

8. Reset the belt clutch handle. Start the engine and run it at full speed. Then, engage the belt clutch handle to the 3/4 position. After 3–5 seconds, fully engage the handle.

HYDRAULIC SYSTEM

- **Fire and Explosion Risk:** Hydraulic oil is flammable and can evaporate under high temperatures, posing serious risks such as fire or explosion. Keep hydraulic oil away from ignition sources, including open flames, sparks, and smoking areas.
- **Slipping Hazard:** Leaks can cause hydraulic fluid to accumulate on the ground, creating slippery conditions that may lead to serious injury. Clean up any spilled oil promptly and repair leaks immediately.
- **High-Pressure Injection Hazard:** Hydraulic oil under high pressure—such as in hydraulic cylinders—can be ejected from leaks with great force. This may result in serious burns or even injection injuries where oil penetrates the skin. If this occurs, seek immediate medical attention.
- **Burn Hazard:** Hydraulic components (e.g., pumps, motors) and the oil itself may become extremely hot during operation. Contact with these parts can cause severe burns.
- **Personal Protective Equipment (PPE):** Always wear appropriate protective equipment—such as safety goggles, gloves, and protective clothing—during operation and maintenance of the hydraulic system.

 Wait for the machine to cool down completely.

The hydraulic oil should be tested every 250 hours for signs of aging. The signs of aging include:

- The color of the hydraulic oil changes.
- The smell of hydraulic oil has changed.
- It feels that there is dirt or sand in the hydraulic oil.
- Hydraulic components fail regularly.
- The operating noise is larger than normal.

Under normal conditions, replace hydraulic oil every 2000 hours or annually (1000 hours or every 6 months under severe conditions), always using anti-wear hydraulic oil and maintaining the oil level at three-quarters of the tank to prevent air intake, pressure loss, and slow machine operation.

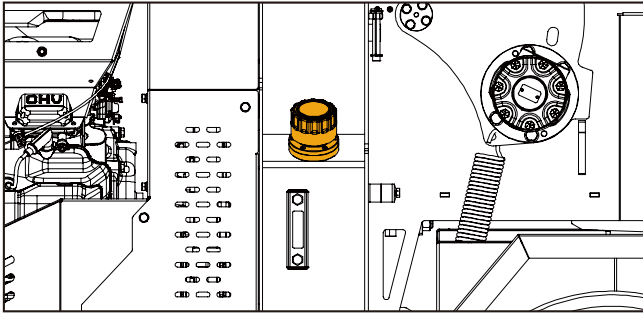

OIL RETURN FILTER

Fire and Explosion Risk: Hydraulic oil is flammable and can evaporate under high temperatures, posing serious risks such as fire or explosion. Keep hydraulic oil away from ignition sources, including open flames, sparks, and smoking areas.

Replace the hydraulic oil filter every 500 working hours or whenever the hydraulic oil is changed, whichever comes first.

Use a 10-micron filter and wear protective plastic gloves to avoid skin contact with oil. Dispose of used oil and filters responsibly and in accordance with environmental regulations.

Replacement Steps:

1. Unscrew the top of the filter housing and remove the old filter element.
2. Insert the new filter element and securely screw the filter housing back in place

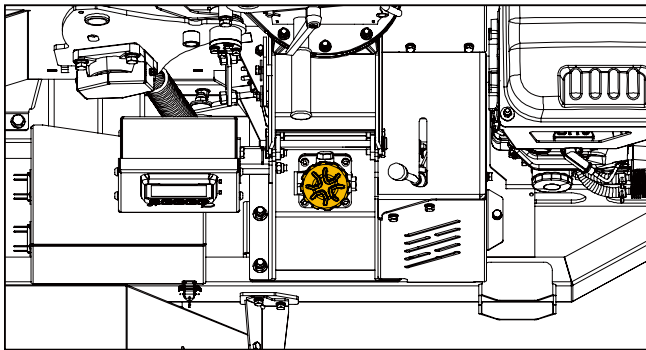

CHECK HOSES

All the hydraulic hoses should be regularly inspected for chafing and leaks. The hydraulic system is pressurized to 150 Bar and thus the equipment containing it must be kept in good condition.

Identify the hoses that run to the top motor. These have the highest chance of damage as they are constantly moving. If any hydraulic components are changed new seals should be installed during reassembly. Fittings should then be retightened.

RECOMMENDED OIL

Use 4-stroke motor oil that meets or exceeds the requirements for API service category SJ or later (or equivalent). Always check the API service label on the oil container to be sure it includes the letters SJ or later (or equivalent).

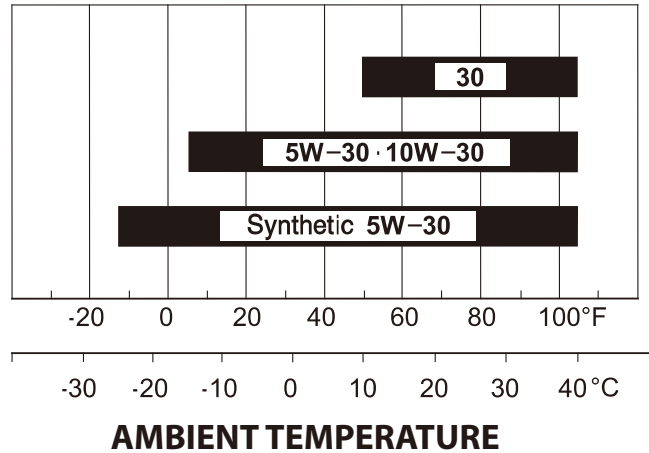

SAE 10W-30 or 5W-30 is recommended for general use. Use a full synthetic 5W-30 for starting/operating temperatures between 5°F (-15°C) and 13°F (-25°C). Other viscosities shown in the chart may be used when the average temperature in your area is within the indicated range.

REFUELING

Recommended Fuel

This engine is certified to operate on unleaded gasoline with a pump octane rating of 86 or higher (a research octane rating of 91 or higher). Refuel in a well ventilated area with the engine stopped. If the engine has been running, allow it to cool first. Never refuel the engine inside a building where gasoline fumes may reach flames or sparks. You may use unleaded gasoline containing no more than 10% ethanol (E10) or 5% methanol by volume. In addition, methanol must contain cosolvents and corrosion inhibitors. Use of fuels with content of ethanol or methanol greater than shown above may cause starting and/or performance problems. It may also damage metal, rubber, and plastic parts of the fuel system. Engine damage or performance problems that result from using a fuel with percentages of ethanol or methanol greater than shown above are not covered under the Warranty.

ENGINE SERVICING

All engine servicing must be performed in accordance with the Engine Manufacturer's handbook provided with the machine. **FAILURE TO ADHERE TO THIS MAY INVALIDATE WARRANTY AND/OR SHORTEN THE LIFE OF THE ENGINE.**

TROUBLESHOOTING

Problem	Cause	Remedy
Engine fails to start	<ol style="list-style-type: none"> 1. Spark plug wire is disconnected. 2. Out of fuel or stale fuel. 3. Engine and/or Fuel valve is not in ON position. 4. Choke lever is not in CLOSE position. 5. Blocked fuel line. 6. Fouled spark plug. 7. Engine flooding. 	<ol style="list-style-type: none"> 1. Attach spark plug wire securely to spark plug. 2. Fill with clean, fresh gasoline. 3. Engine and Fuel valve must be in ON position. 4. Choke lever must be in CLOSE position for a cold start. 5. Clean fuel line. 6. Clean, adjust gap, or replace. 7. Wait a few minutes to restart, but do not prime.
Engine runs erratically	<ol style="list-style-type: none"> 1. Spark plug wire is loose. 2. Unit running with Choke lever in CLOSE position. 3. Blocked fuel line or stale fuel. 4. Vent plugged. 5. Water or dirt in fuel system. 6. Dirty air cleaner. 7. Improper carburetor adjustment. 	<ol style="list-style-type: none"> 1. Connect and tighten spark plug wire. 2. Move choke lever to OPEN position. 3. Clean fuel line. Fill tank with clean, fresh gasoline. 4. Clear vent. 5. Drain fuel tank. Refill with fresh fuel. 6. Clean or replace air cleaner. 7. Refer to engine manual.
Engine overheats	<ol style="list-style-type: none"> 1. Engine oil level low. 2. Dirty air cleaner. 3. Air flow restricted. 4. Carburetor not adjusted properly. 	<ol style="list-style-type: none"> 1. Fill crankcase with proper oil. 2. Clean air cleaner. 3. Remove housing and clean. 4. Refer to engine manual.
Chipping action seems too slow, cutting disk stalls, or no material is discharged when engine is running	<ol style="list-style-type: none"> 1. Engine speed is too slow causing belt to slip. 2. Drive Belt is loose or damaged. 3. Knives are dull or damaged. 4. Cutting disk is jammed by debris from the feed hopper and discharge chute. 5. Discharge chute is clogged. 	<ol style="list-style-type: none"> 1. Run the engine at full throttle. 2. Tighten or replace drive belt. 3. Sharpen or replace knives. 4. Remove any built-up debris and turn cutting disk with a wooden stick to be sure it turns freely. 5. Clean out debris.

Problem	Cause	Remedy
The belt frays or rolls over the pulley	<ol style="list-style-type: none">1. Rotor drive pulley groove may be nicked.2. Drive belts may be stretched.3. Pulleys may be misaligned.	<ol style="list-style-type: none">1. Check drive belts for wear and hard spots. File off any nicks on the pulley.2. Replace drive belts.3. Adjust pulleys.
When chipping, branch seems to vibrate and move about excessively with unusual noise	<ol style="list-style-type: none">1. Knives are dull or damaged.2. Knives are not properly seated on the cutting disk.3. The gap between the knives and wear plate is too large.4. Rotor is overloaded with material.	<ol style="list-style-type: none">1. Sharpen or replace knives.2. Loosen the knife mounting screws, reset the knives, and tighten the screws.3. Adjust the gap.4. Allow unit to clear itself before adding more material to the hopper.
Chipper Knives are hitting the wear plate	The gap between the knives and wear plate is set incorrectly.	Adjust the gap.
The machine's wheels track left or right while being towed	Low tire pressure.	Add air to tires.

PARTS DIAGRAM

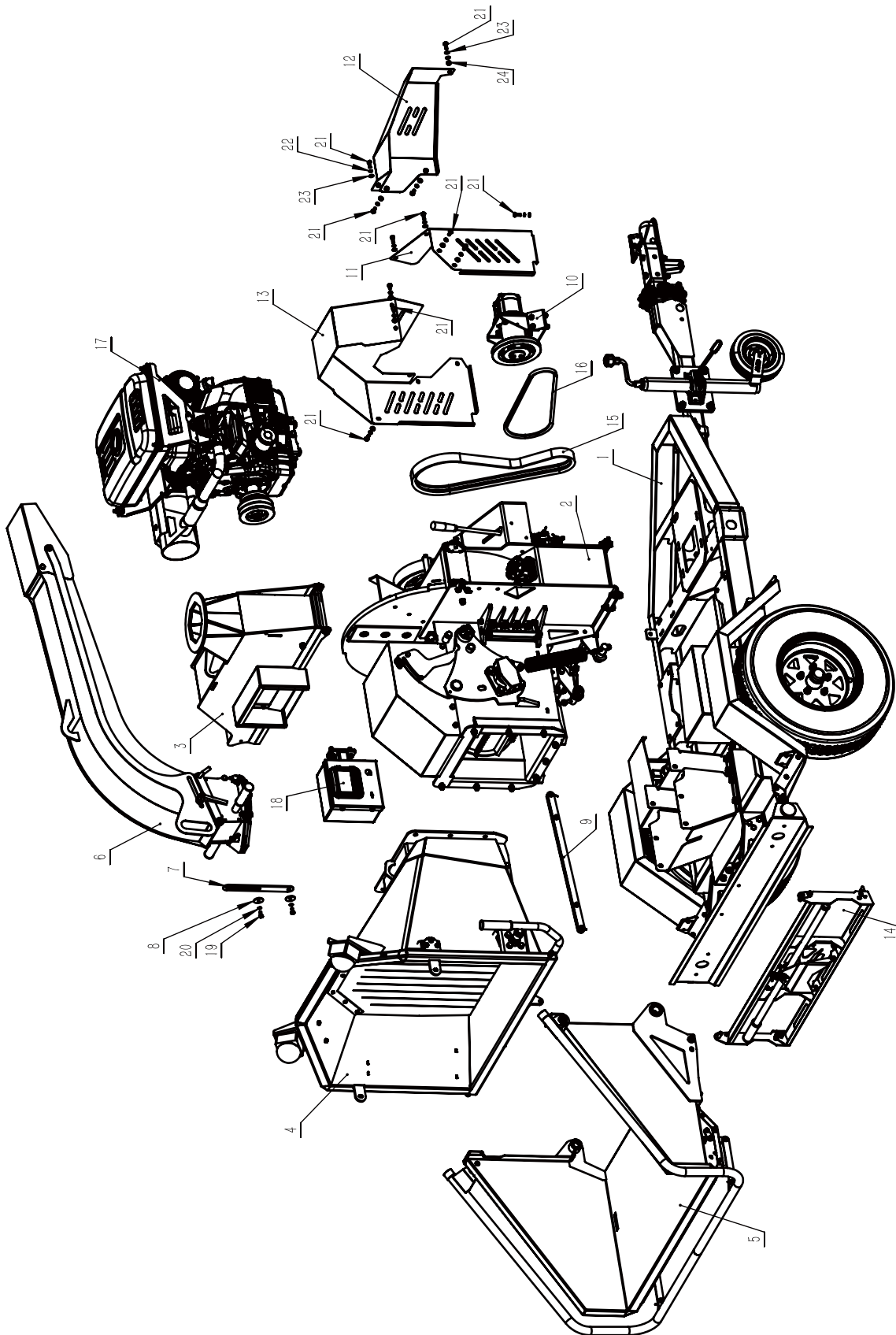

PARTS LIST

NO.	Description	Qty.
1	Chasis assembly	1
2	Disc house assembly	1
3	Disc cover assembly	1
4	In-feed hopper	1
5	Feed tray	1
6	Discharge chute assembly	1
7	Top cover plate	1
8	Pressure plate	2
9	Direction-changing rod	1
10	Pump assembly	1
11	Right belt cover	1
12	Left belt cover	1

NO.	Description	Qty.
13	Top belt cover	1
14	Folding baffle plate assembly	1
15	Disc Belt 2SB1505LE	1
16	Pump belt AV13x1185le(A46)	1
17	Engine assembly	1
18	Controller assembly	1
19	Hex bolt M8*16	2
20	Spring washer 8	2
21	Hex bolt M8*20	12
22	Spring washer 8	11
23	Flat washer 8	13
24	Hex nut M8	1

PARTS DIAGRAM

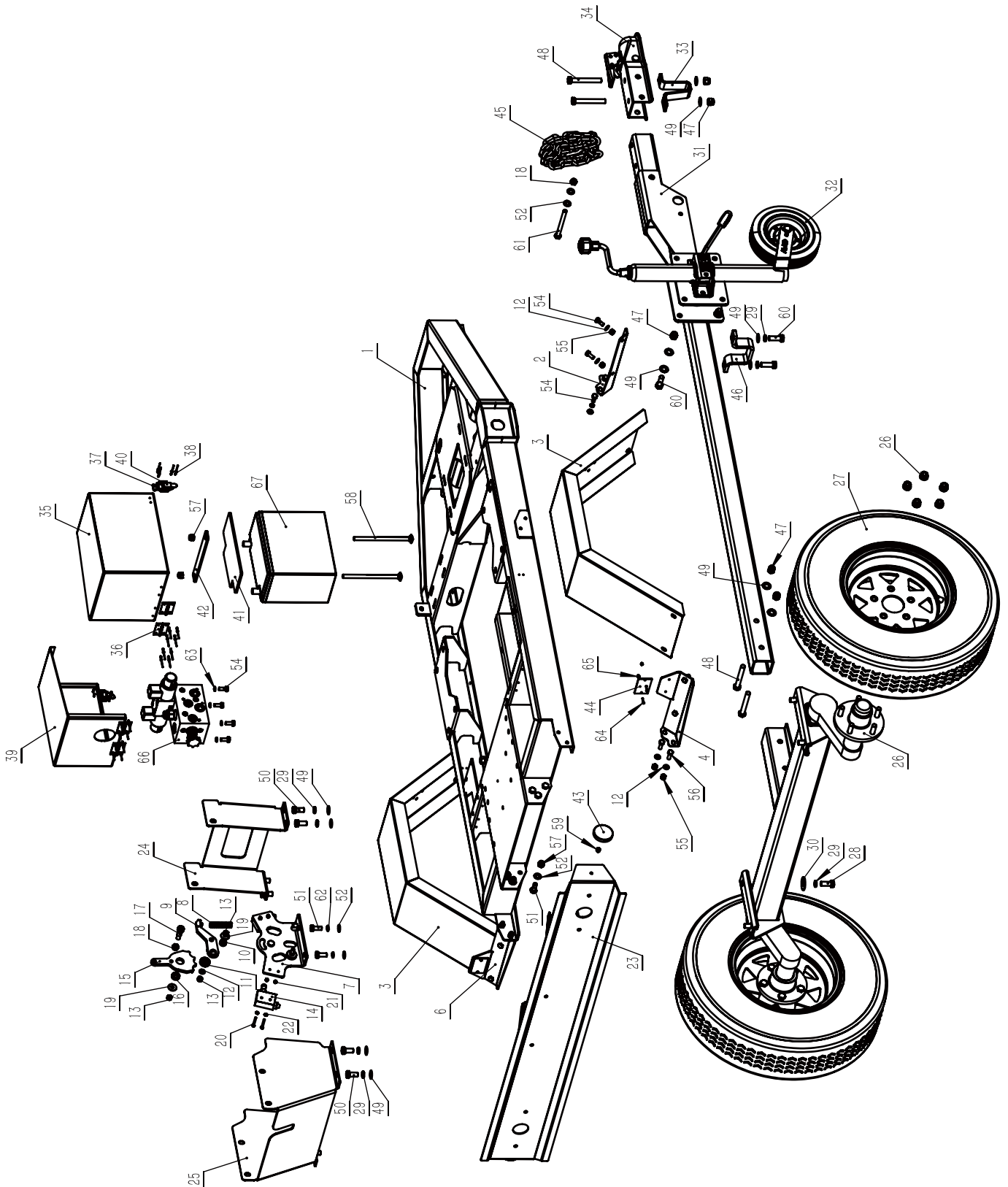

PARTS LIST

NO.	Description	Qty.
1	Chassis base	1
2	Mudguard front right bracket	1
3	Mudguard	2
4	Mudguard rear right bracket	1
5	Mirror tyre mudguard front right bracket	1
6	Mirror tyre mudguard rear right bracket	1
7	Direction-changing fixing plate	1
8	Direction-changing spring	1
9	Fixing plate pin-lift	1
10	Direction-changing bearing Sleeve	1
11	Bearing 6001-2RZ	1
12	Flat washer 8	17
13	Thin nut M8	3
14	Limit switch CZ-7311	2
15	Direction-changing handle	1
16	Direction-changing bearing bushing	1
17	Screw $\phi 12 \times 20$ -M10x16.4	1
18	Thin nut M10	2
19	Washer 8	2
20	Screw M4*35	4
21	Thin nut M4	4
22	Flat washer 4	4
23	Rear light plate	1
24	In-feed hopper bracket	1
25	In-feed hopper support plate	1
26	Torsion bar	1
27	Wheel $\phi 594 \times 165$	2
28	Hex bolt M12*30	4
29	Sping washer 12	14

NO.	Description	Qty.
30	Washer 12	4
31	Tow bar	1
32	Jockey wheel 8"	1
33	Coupler bent bracket	1
34	Coupler latch	1
35	Battery cover	1
36	Battery cover hinge	4
37	Small latch	2
38	Rivet 3*10	24
39	Solenoid valve cover	1
40	Small latch	2
41	Battery top rubber	1
42	Battery top plate	1
43	Yellow reflector plate	2
44	White reflector plate	2
45	Safty chain	1
46	Tow bar bent bracket	1
47	Hex nut M12	8
48	Hex bolt M12*90	4
49	Flat washer 12	22
50	Hex bolt M12*25	8
51	Hex bolt M10*25	8
52	Flat washer 10	10
53	Spring washer 8	4
54	Hex bolt M8*20	16
55	Hex nut M8	12
56	Hex bolt M8*25	4
57	Hex nut M10	8
58	Square bolt M10*170	2

NO.	Description	Qty.
59	Hex nut M6	2
60	Hex bolt M12*35	6
61	Hex bolt M10*110	1
62	Spring washer 10	2
63	Spring washer 8	4

NO.	Description	Qty.
64	Screw M3*16	4
65	Hex nut M3	4
66	Solenoid valve	1
67	Battery 12V45Ah 280A	1

PARTS DIAGRAM

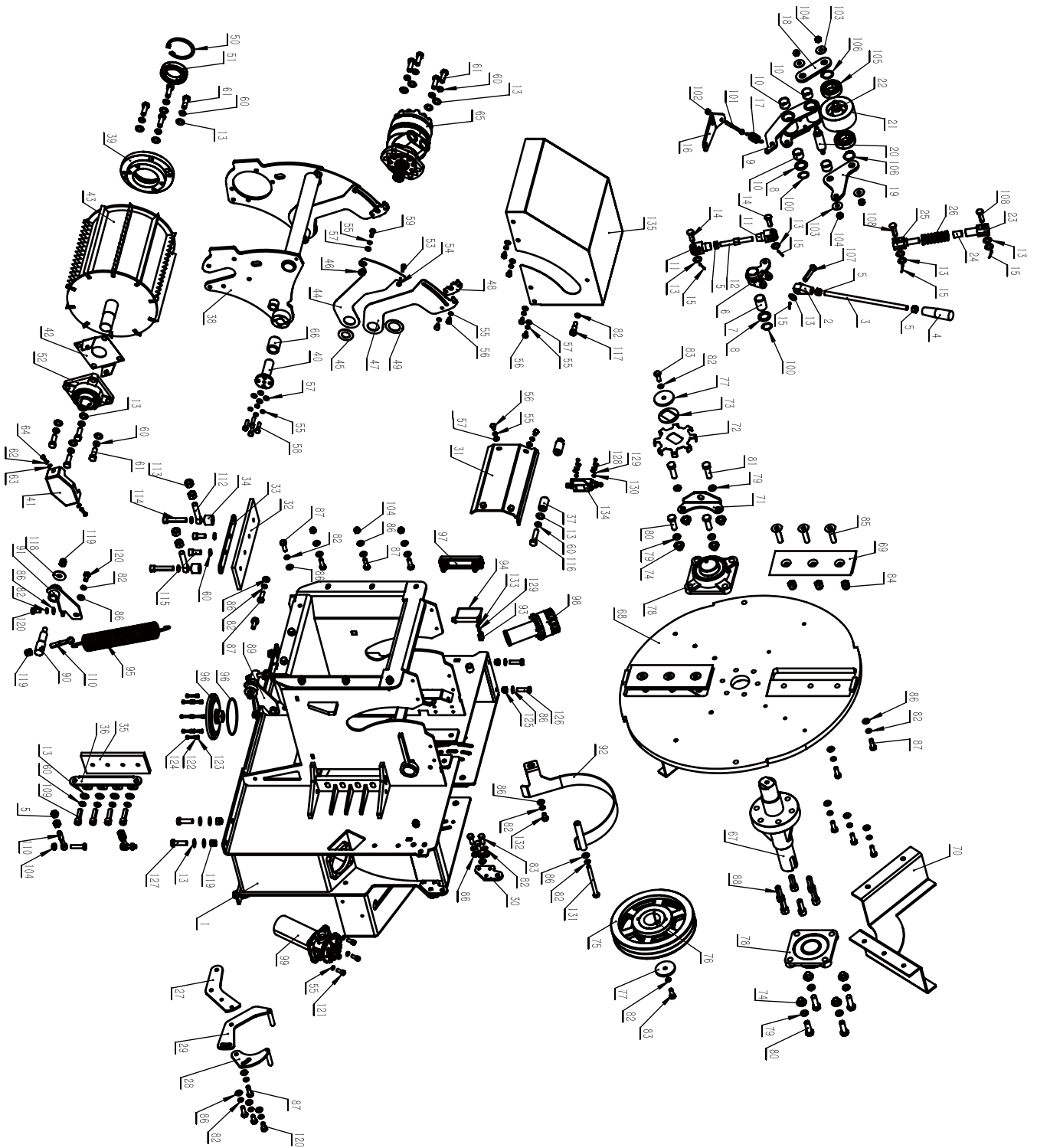

PARTS LIST

NO.	Description	Qty.
1	Disc Frame house	1
2	Handle rotating	1
3	Handle rotating rod	1
4	Handle bar M12*100	1
5	Hex nut M12	7
6	Clutch handle shift sleeve	1
7	Shift bearing $\phi 25 \times \phi 29 \times 40$	1
8	Washer $\phi 25 \times \phi 37 \times 3$	2
9	Clutch connecting rod	1
10	Clutch connecting rod sleeve	4
11	Two sides screw-Y head	2
12	Two sides screw rod	1
13	Flat washer 12	41
14	Pin 12*35	2
15	Cotter pin 3.2*22	5
16	Handle spring fixing plate	1
17	Handle spring $\phi 22 \times \phi 2 \times 70$	1
18	Clutch connecting plate A	1
19	Clutch connecting plate B	1
20	Clutch connecting shaft	1
21	Clutch connecting tension wheel	1
22	Tension wheel shaft	1
23	Tension nut head	1
24	Tension sleeve $\phi 15 \times \phi 18 \times 25$	1
25	Tension bolt head	1
26	Tension spring	1
27	Plate 1	1
28	Plate 3	1
29	Plate 2	1

NO.	Description	Qty.
30	Hinge plate	2
31	Speed sensor cover	1
32	Bottom Anvil	1
33	Bottom anvil plate	1
34	Anvil bushing	2
35	Side Anvil	1
36	Side anvil plate	1
37	Limit stop collar	2
38	Roller bracket	1
39	Motor flange	1
40	Roller bracket shaft	2
41	Bearing end cap	1
42	Bearing base plate	1
43	Roller	1
44	Roller plate 1	2
45	Thick washer	2
46	Roller plate shaft sleeve	2
47	Roller plate 2	2
48	Roller plate 3	2
49	Thin washer	2
50	Circlip 80B	1
51	Bearing 6010-2RZ	1
52	Bearing UELFU207	1
53	Screw $\phi 8 \times 5$ -M6x12	2
54	Thin nut M6	2
55	Spring washer 8	30
56	Hex bolt M8*12	16
57	Flat washer 8	22
58	Hex bolt M8*30	8

NO.	Description	Qty.
59	Hex bolt M8*20	2
60	Spring washer 12	22
61	Hex bolt M12*35	12
62	Spring washer 6	2
63	Flat washer 6	2
64	Hex bolt M6*12	2
65	Hydraulic motor	1
66	Shaft sleeve $\phi 25 \times \phi 35 \times 40$	2
67	Disc shaft	1
68	Disc	1
69	Blade	2
70	Fan	2
71	Speedometer plate	1
72	Tachometer plate	1
73	Speed plate	1
74	Bearing bolt bushing	8
75	Pulley SPB250-02-2517- $\phi 50$	1
76	Key B14x9x45	1
77	Pulley end plate	2
78	Bearing UCFU210	2
79	Spring washer 14	14
80	Hex bolt M14*40	6
81	Hex bolt M14*45	2
82	Spring washer 10	35
83	Hex bolt M10*25	8
84	Hex nut M14	6
85	Screw M14*60	6
86	Flat washer 10	45
87	Hex bolt M10*30	23
88	Screw M14*40	6
89	Roller spring left base	1
90	Roller spring	2

NO.	Description	Qty.
91	Roller spring right base	1
92	Pulley cover	1
93	Shrapnel pin	1
94	Pin $\phi 12 \times 60$	1
95	Roller spring $\phi 50 \times \phi 6 \times 332$	2
96	Oil outlet flange	1
97	Level gauge	1
98	Breathing cap	1
99	Return filter	1
100	Circlip B type 25	2
101	Eye Bolt M8*70	1
102	Thin nut M8	1
103	Washer 10	4
104	Thin nut M10	12
105	Bearing 6206-2Z	2
106	Circlip B type 30	2
107	Pin B type 12*55	1
108	Pin B type 12*40	2
109	Screw M12*40	4
110	Eye bolt M12*70	4
111	Hex bolt M10*40	2
112	Eye bolt M14*70	2
113	Hex nut M14	4
114	Screw M12*60	2
115	Screw M12*25	2
116	Hex bolt M12*50	2
117	Screw $\phi 12 \times 20$ -M10x16.4	2
118	Washer 12	2
119	Hex nut M12	12
120	Hex bolt M10*20	6
121	Screw M8*20	4
122	Spring washer 5	8

NO.	Description	Qty.
123	Flat washer $\phi 5.5 \times \phi 10 \times 1$	8
124	Screw M5*20	8
125	Hex nut M10	2
126	Hex bolt M10*35	2
127	Hex bolt M12*40	8
128	Screw M4*20	4
129	Spring washer 4	5

NO.	Description	Qty.
130	Flat washer 4	4
131	Hex bolt M10*120	1
132	Hex bolt M10*20	1
133	Screw M4*8	1
134	Limit switch ME8112	1
135	Roller cover	1

PARTS DIAGRAM

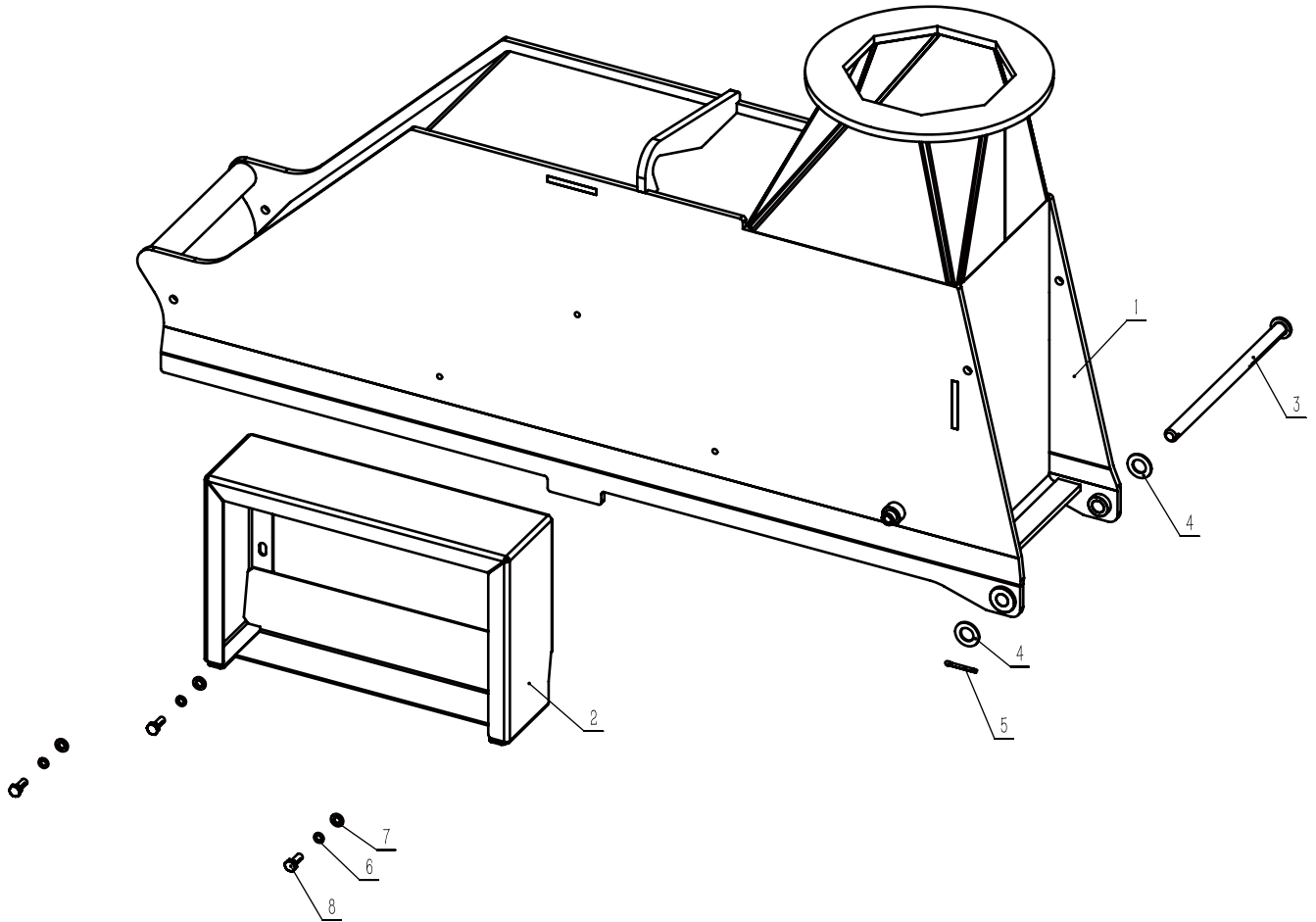

PARTS LIST

NO.	Description	Qty.
1	Disc top cover	1
2	Sensor top cover	1
3	Pin B type 12*215	1
4	Flat washer 12	2

NO.	Description	Qty.
5	Cotter pin 3.2*22	1
6	Spring washer 6	3
7	Flat washer 6	3
8	Hex bolt M6*16	3

PARTS DIAGRAM

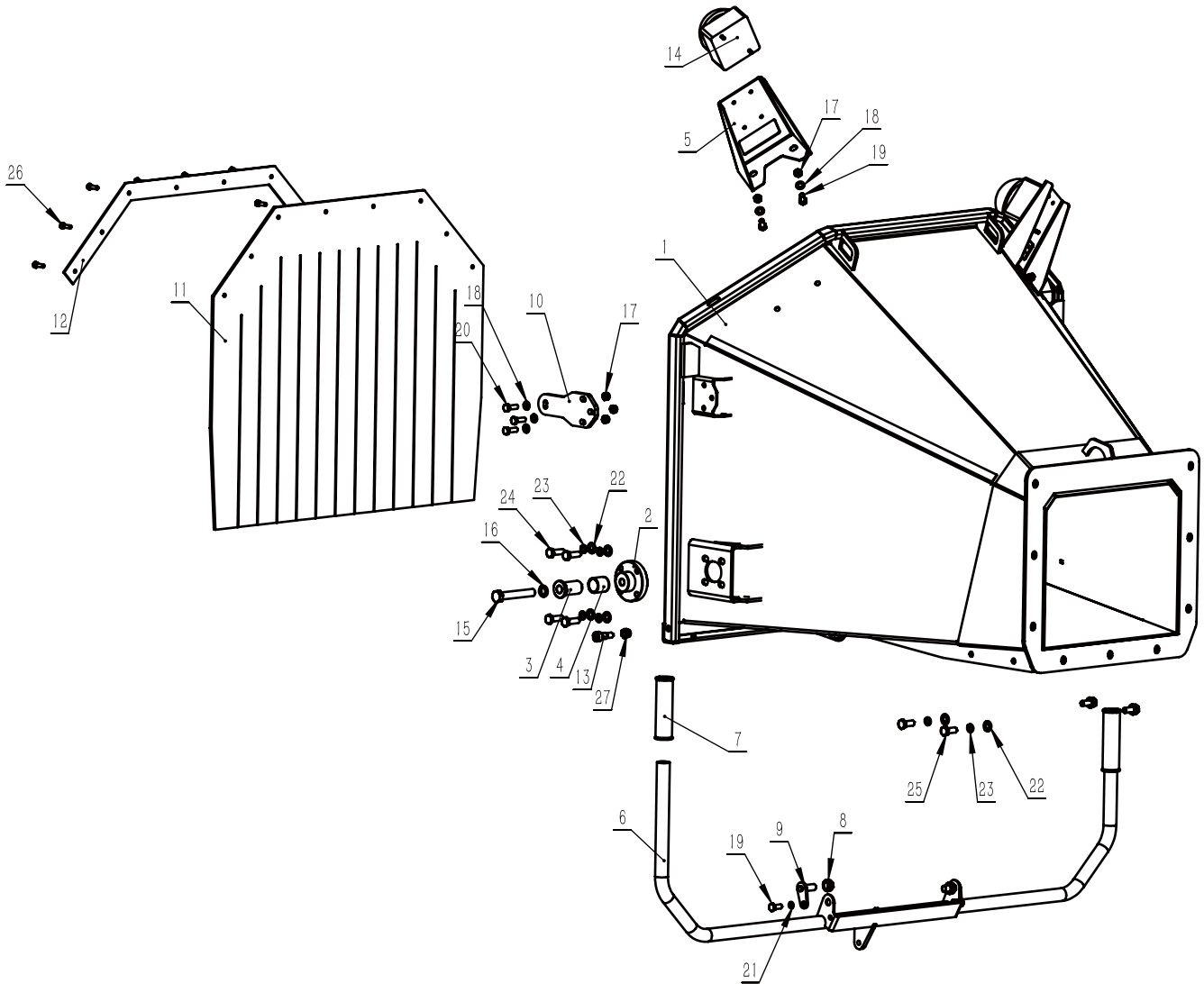

PARTS LIST

NO.	Description	Qty.
1	In-feed hopper	1
2	Feed tray mounting base	2
3	Shaft sleeve	2
4	Graphite bearing $\phi 29 \times \phi 25 \times 30$	2
5	Emergency stop button box	2
6	Direction-changing rod	1
7	Pipe sleeve	2
8	Bearing GE12C $\phi 22 \times \phi 12 \times 10$	2
9	Trunnion	2
10	Latch seat	2
11	Rubber baffle	1
12	Baffle plate	1
13	Screw $\phi 12 \times 16$ -M10 $\times 16.4$	2
14	Emergency stop button	2

NO.	Description	Qty.
15	Hex bolt M14*90	2
16	Spring washer 14	2
17	Thin nut M8	10
18	Flat washer 8	10
19	Hex bolt M8*20	6
20	Hex bolt M8*25	6
21	Spring washer 8	2
22	Flat washer 10	12
23	Spring washer 10	12
24	Hex bolt M10*30	8
25	Hex bolt M10*25	4
26	Hex bolt M6*20	8
27	Hex nut M10	2

PARTS DIAGRAM

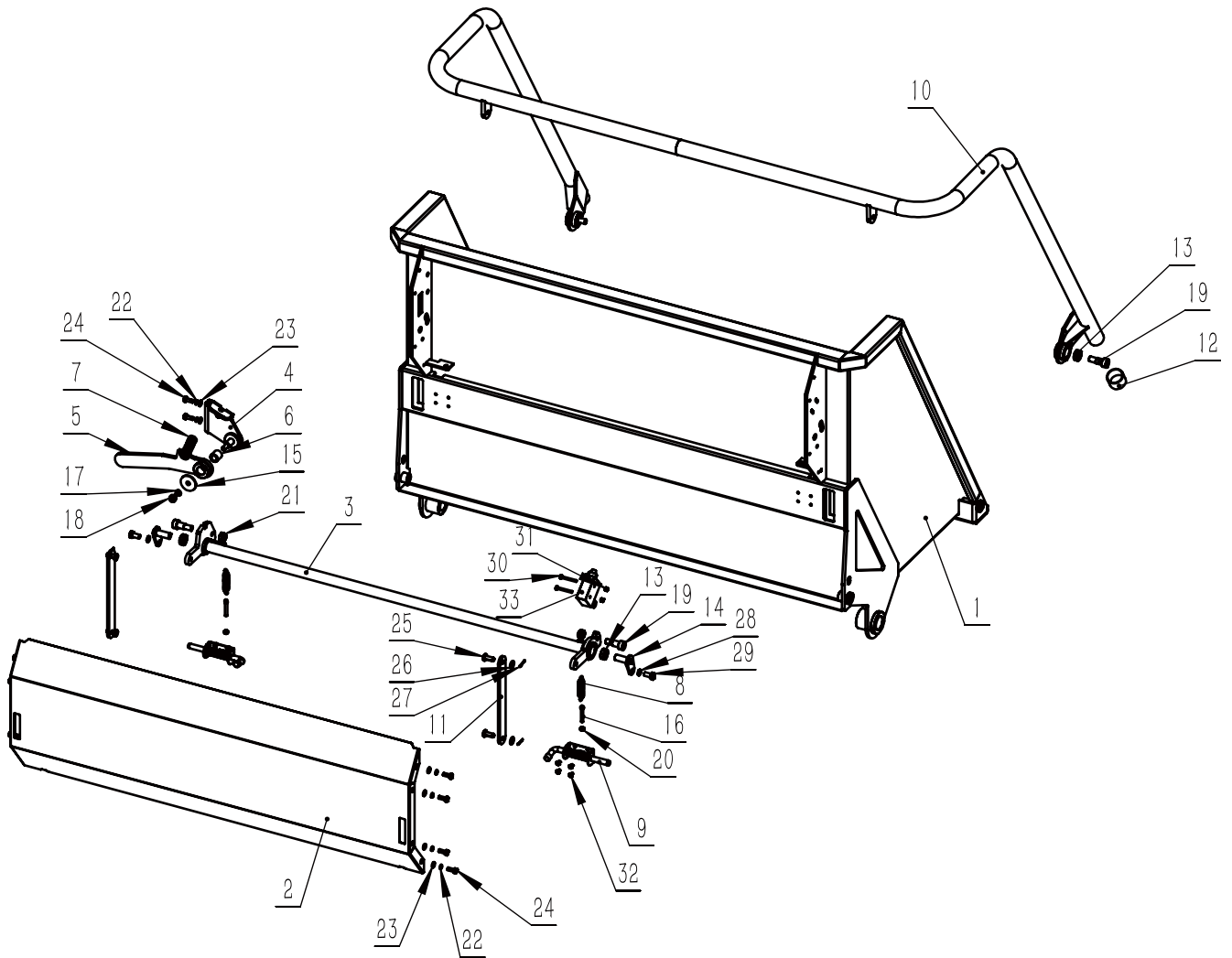

PARTS LIST

NO.	Description	Qty.
1	Feed tray	1
2	Cover plate	1
3	Emergency stop shaft	1
4	Return rod base	1
5	Return rod	1
6	Graphite bearing $\phi 18 \times \phi 12 \times 19$	1
7	Return compression spring	1
8	Return spring	2
9	Spring latch	2
10	Emergency stop bar	1
11	Emergency stop connection rod	2
12	Pipe end cover	2
13	Bearing GE12C $\phi 22 \times \phi 12 \times 10$	4
14	Trunnion	2
15	Plate	1
16	Eye bolt M5*35- $\phi 4.2$	2
17	Spring washer 8	1

NO.	Description	Qty.
18	Thin nut M8	1
19	Screw $\phi 12 \times 16$ -M10x16.4	4
20	Thin nut M5	2
21	Thin nut M10	2
22	Spring washer 6	10
23	Flat washer 6	10
24	Hex bolt M6*16	10
25	Pin B type 8*20	4
26	Flat washer 8	4
27	Cotter pin 2*16	4
28	Spring washer 8	2
29	Hex bolt M8*16	2
30	Screw M4*35	2
31	Thin nut M4	2
32	Screw M4*8	8
33	Limit switch CZ-7311	1

PARTS DIAGRAM

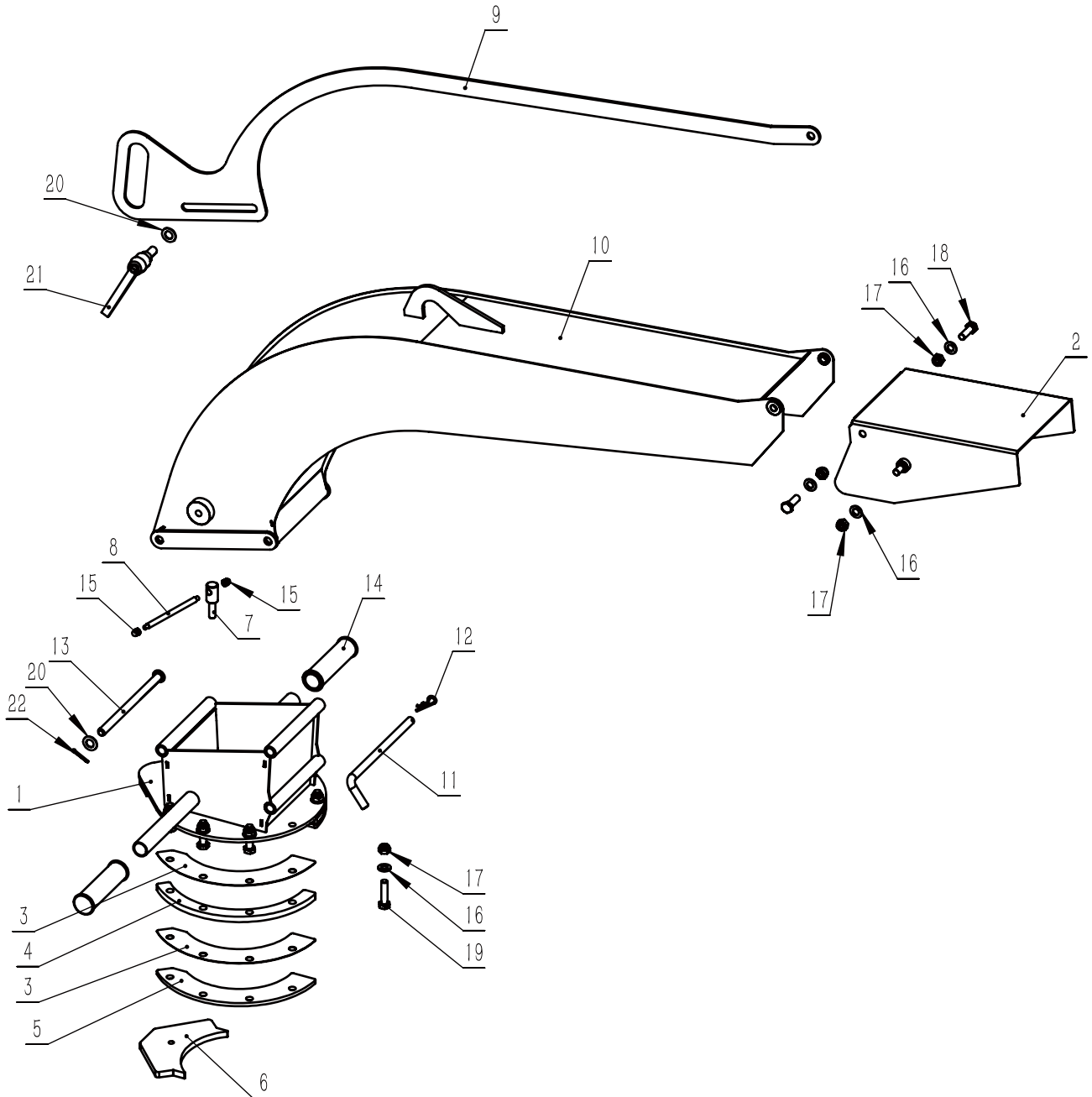

PARTS LIST

NO.	Description	Qty.
1	Outlet base	1
2	Outlet deflector	1
3	Thin plate	4
4	Base Plate	2
5	Dam board	2
6	Press board	1
7	Compression bolt	1
8	Function lever	1
9	Adjusting board	1
10	Discharge tank	1
11	Pin shaft	1

NO.	Description	Qty.
12	R type Pin 03*45	1
13	B type pin 12*195	1
14	Handle sleeve ϕ 25	2
15	Hex nut M6	2
16	Flat washer 10	11
17	Thin nut M10	11
18	Hex bolt M10*30	2
19	Hex bolt M10*40	8
20	Flat washer 12	2
21	Adjustable locking handle	1
22	Cotter pin 3.2*22	1

PARTS DIAGRAM

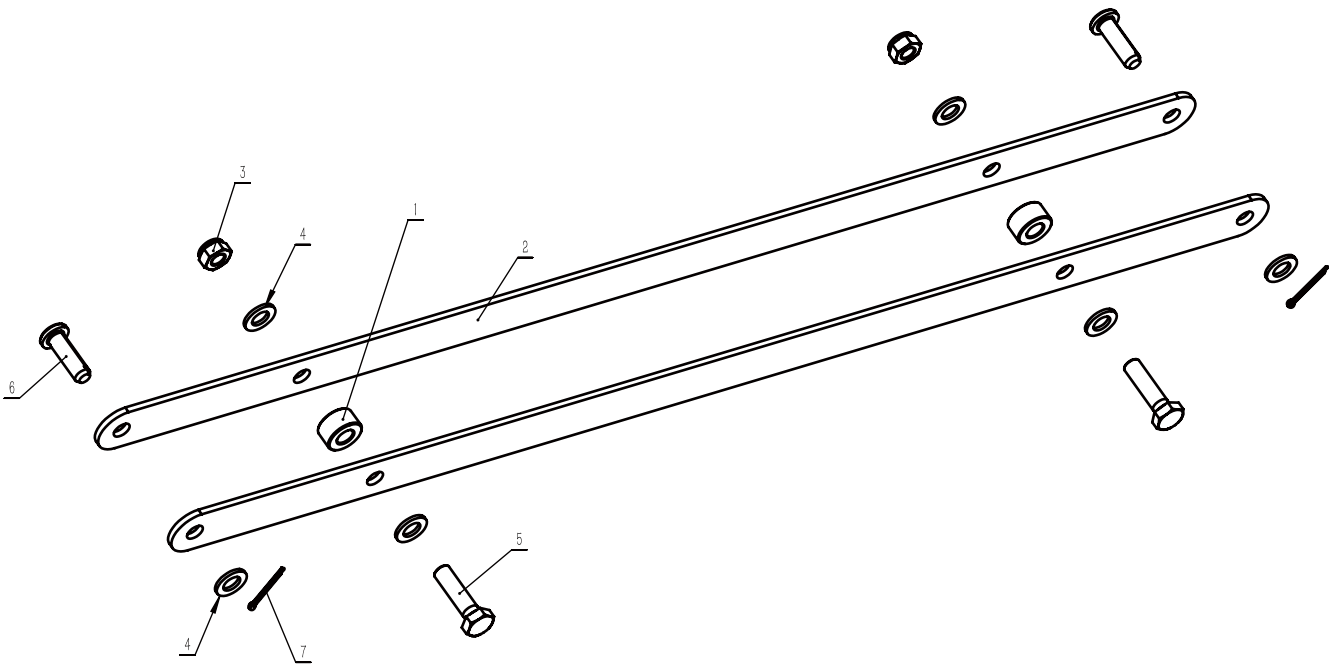

PARTS LIST

NO.	Description	Qty.
1	Direction-changing linkage sleeve	2
2	Direction-changing board	2
3	Thin nut M8	2
4	Flat washer 8	6

NO.	Description	Qty.
5	Hex bolt M8*30	2
6	Pin B tie 8*26	2
7	Cotter pin 2*20	2

PARTS DIAGRAM

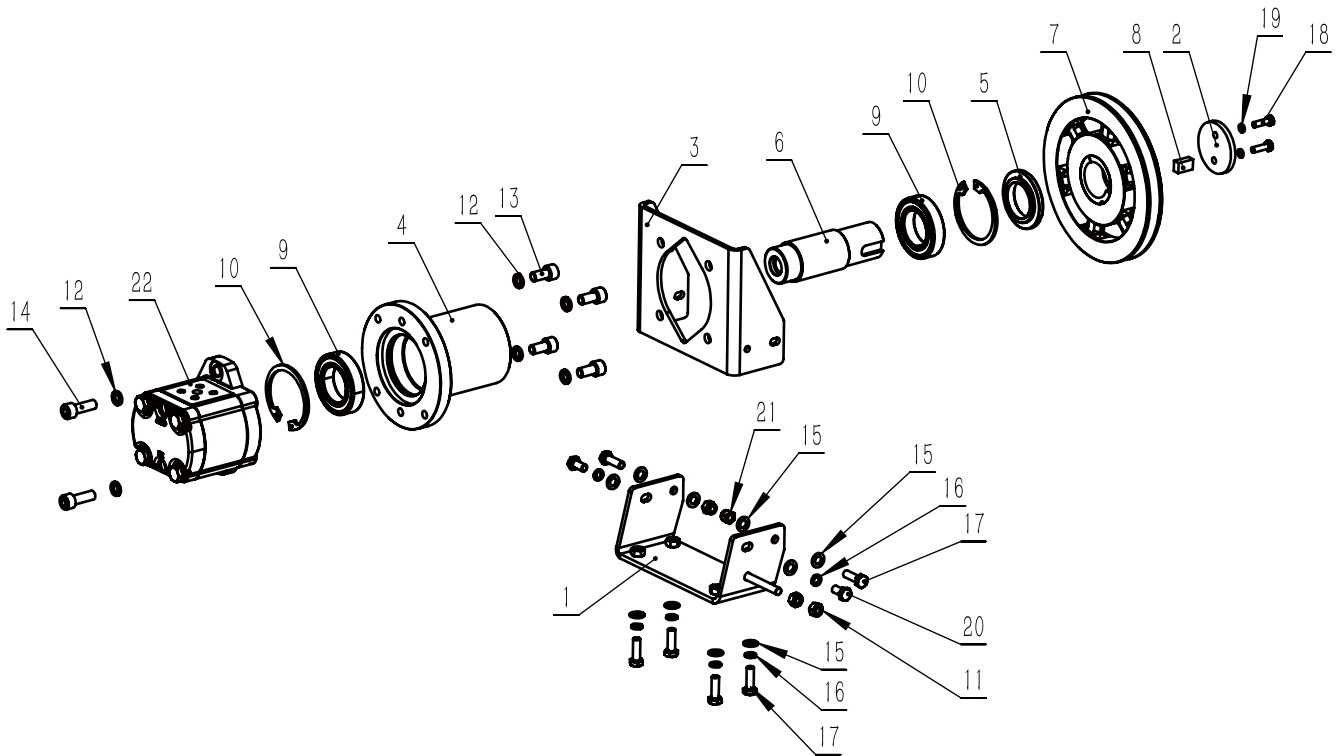

PARTS LIST

NO.	Description	Qty.
1	Oil pump base	1
2	Pump end board	1
3	Pump bracket board	1
4	Pump Transimission bracket	1
5	Pump transimission end cap	1
6	Pump transmission shaft	1
7	Pulley 180-1-1601-φ40	1
8	Shaft key B12x8xL20	1
9	Bearing 6008-2RZ	2
10	Circlip B type 68B	2
11	Hex nut M8	2

NO.	Description	Qty.
12	Spring washer 10	6
13	Hex screw M10*20	4
14	Hex screw M10*30	2
15	Flat washer 8	10
16	Spring washer 8	6
17	Hex bolt M8*25	6
18	Hex bolt M6*20	2
19	Spring washer 6	2
20	Hex bolt M8*16	2
21	Hex nut M8	2
22	Pump CBWKA-F308-AFΦ11L	1

PARTS DIAGRAM

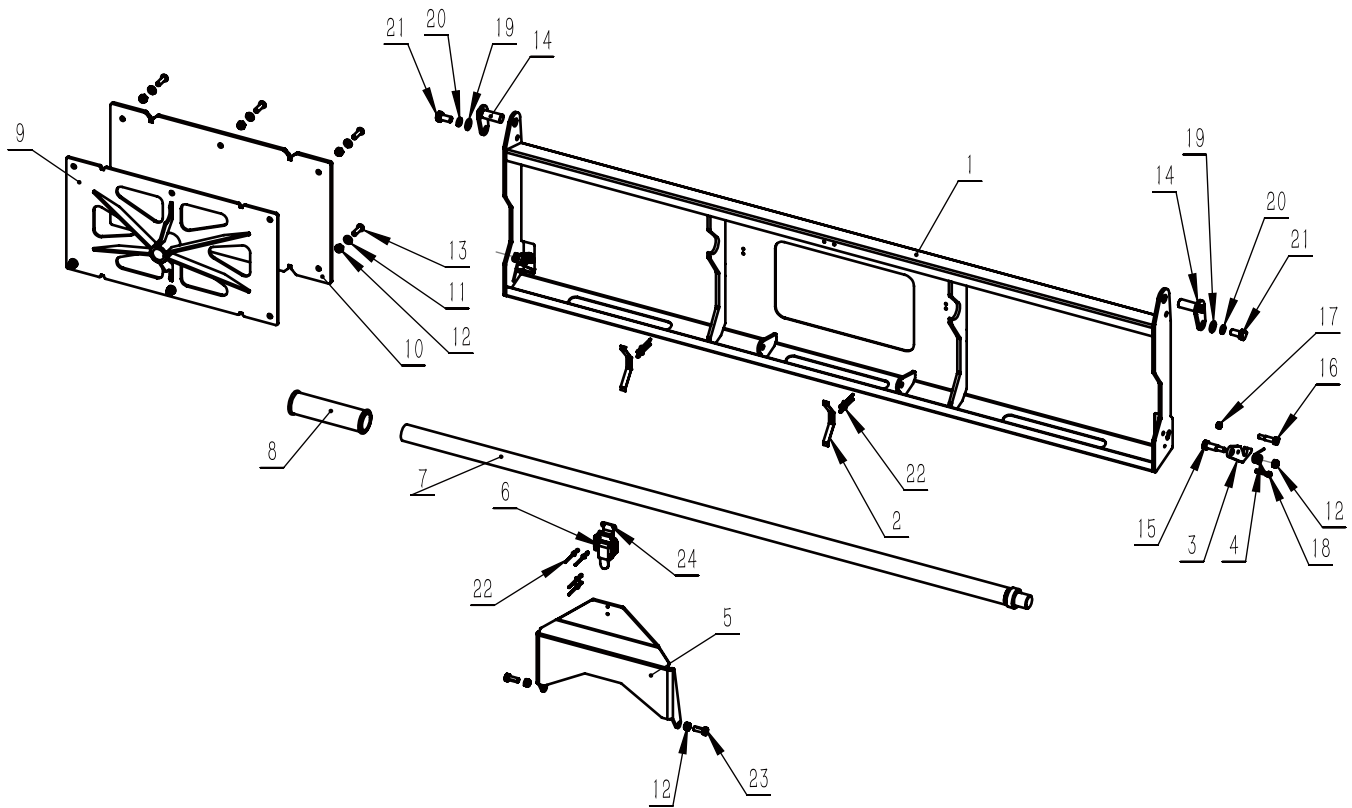

PARTS LIST

NO.	Description	Qty.
1	Folding baffle plate	1
2	Folding spring plate	2
3	Folding lock board	2
4	Torsion spring $\varphi 12 \times \varphi 1.5 \times 11$	2
5	Pressure plate	1
6	Small latch	1
7	Push-out arm	1
8	Handle sleeve	1
9	Push-out plate	1
10	Push-out base plate	1
11	Flat washer 6	6
12	Thin nut M6	10

NO.	Description	Qty.
13	Hex screw M6*20	6
14	Trunnion	2
15	Hex socket Screw $\varphi 8 \times 16$ -M6x12	2
16	Hex socket Screw $\varphi 6 \times 16$ -M5x10	2
17	Thin nut M5	2
18	Screw M4*20	2
19	Flat washer 8	2
20	Spring washer 8	2
21	Hex bolt M8*16	2
22	Rivet 3*10	8
23	Hex bolt M6*16	2
24	Small latch	1

PARTS DIAGRAM

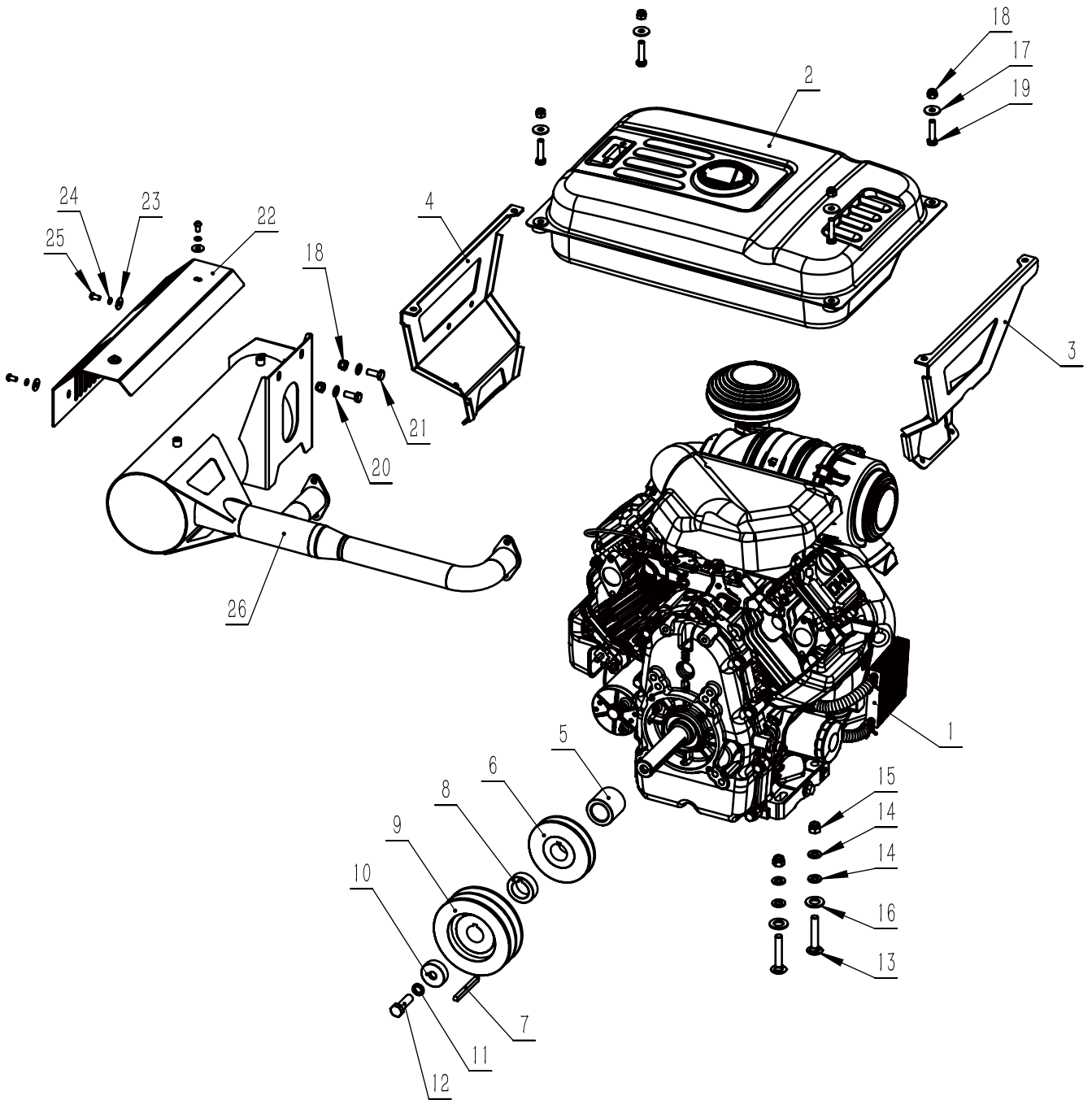

PARTS LIST

NO.	Description	Qty.
1	Zonsen 35HP Engine	1
2	Fuel tank	1
3	Tank right bracket	1
4	Tank left bracket	1
5	Impeller Spacer sleeve	1
6	Impeller	1
7	Engine shaft key 6.35x6.35x25	1
8	Pulley spacer sleeve	1
9	Pulley SPB125-02-2012-φ28.575	1
10	Engine shaft end cap	1
11	Spring washer 12	1
12	Hex bolt M20*1.5	1
13	Squire bolt M10*60	4

NO.	Description	Qty.
14	Flat washer 10	8
15	Hex nut M10	4
16	Flat washer 14	4
17	Washer 8	4
18	Hex nut M8	6
19	Hex bolt M8*35	4
20	Flat washer 8	4
21	Hex bolt M8*20	2
22	Anti-scalding cover	1
23	Flat washer 6	4
24	Spring washer 6	4
25	Screw M6*12	4
26	Muffler	1

PARTS DIAGRAM

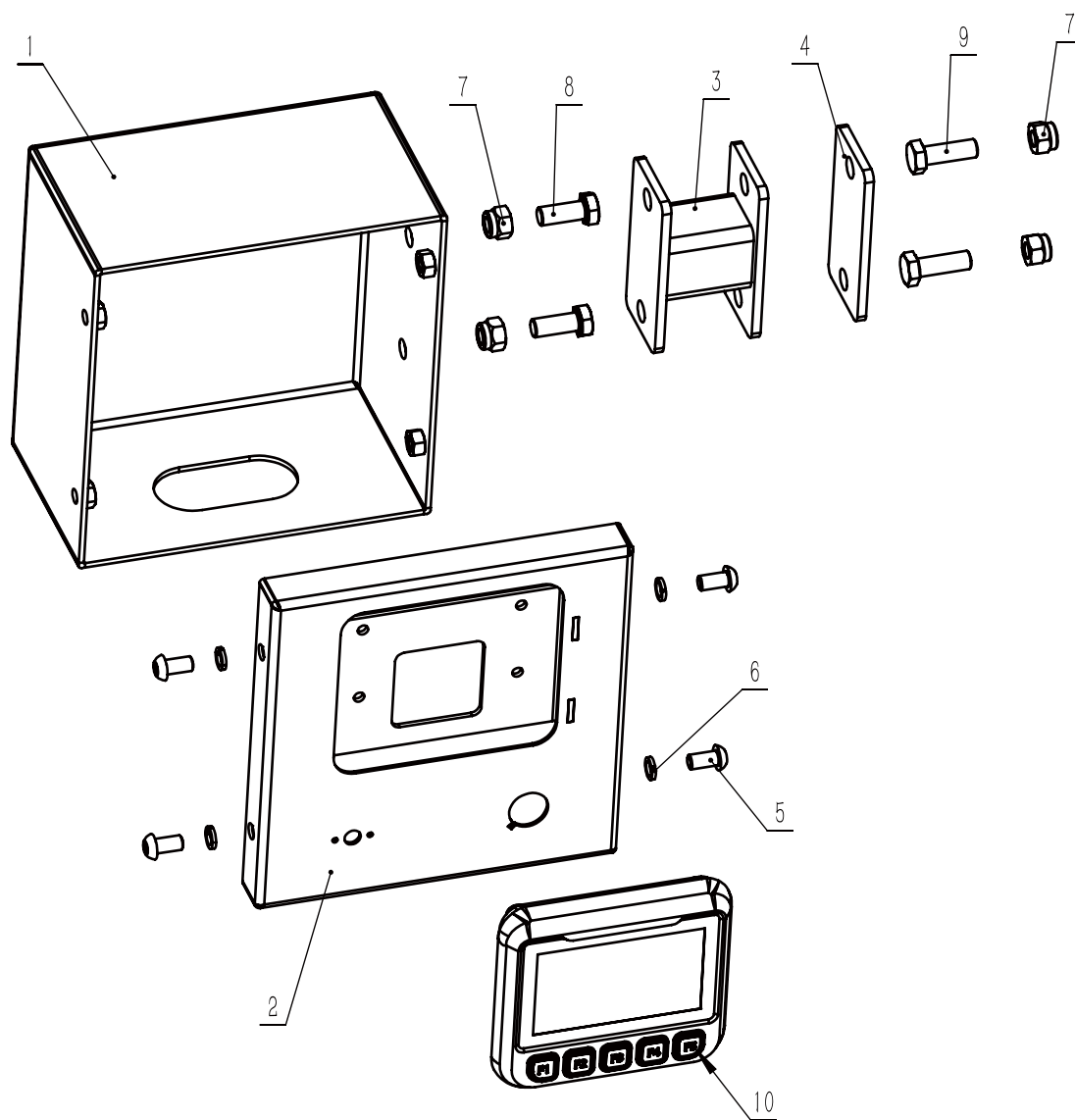

PARTS LIST

NO.	Description	Qty.
1	Controller box	1
2	Controller panel	1
3	Connection pipe	1
4	Controller box rubber plate	1
5	Screw M8*16	4

NO.	Description	Qty.
6	Spring washer 8	4
7	Hex nut M10	4
8	Hex bolt M10*25	2
9	Hex bolt M10*30	2
10	Controller	1

CROBA