

# VAM48/60/65 Flail Mower



## Operator's Manual

**MechMaxx**

[www.mechmaxx.com](http://www.mechmaxx.com)



Your new Flail Mower offers quality construction, and is easy and safe to operate. With proper use and care, it is designed to give you many years of dependable service.

Prepare to experience the durability to take on any job with the ease, portability, and convenience of your new Flail Mower !

**MAX Performance, MAX Value, MAX Support that's Flail Mower**

- ✓ Enhanced design features come standard
- ✓ Engineered for the best user experience
- ✓ Quality metal parts are used instead of plastic
- ✓ A robust warranty supports all products
- ✓ Budget-friendly prices make it practical

**TABLE OF CONTENTS**

<b>TABLE OF CONTENTS</b>	<b>1</b>	<b>DRIVELINE INSTALLATION</b>	<b>11</b>
<b>SPECIFICATIONS</b>	<b>2</b>	<b>OPERATING INSTRUCTIONS</b>	<b>13</b>
<b>SAFETY SIGNS</b>	<b>3</b>	TRANSPORTING	13
<b>IMPORTANT SAFETY INFORMATION</b>	<b>4</b>	MOWING INSTRUCTIONS	13
SAFETY AT ALL TIMES	4	OPERATING INSTRUCTIONS	13
LOOK FOR THE SAFETY ALERT SYMBOL	4	<b>ADJUSTMENTS</b>	<b>14</b>
BE AWARE OF SIGNAL WORDS	4	LEVELING THE MOWER	14
FOR YOU PROTECTION	4	CUTTING HEIGHT ADJUSTMENT	14
SHUTDOWN AND STORAGE	4	3-POINT HITCH ADJUSTMENTS	14
USE SAFETY LIGHTS AND DEVICES	4	<b>MAINTENANCE AND LUBRICATION</b>	<b>15</b>
TRANSPORT MACHINERY SAFELY	5	MAINTENANCE	15
KEEP RIDERS OFF MACHINERY	5	KNIFE REPLACEMENT	15
PRACTICE SAFE MAINTENANCE	5	V-BELT INSTALLATION	15
PREPARE FOR EMERGENCIES	5	STORAGE	15
WEAR PROTECTIVE EQUIPMENT	5	LUBRICATION	15
AVOID HIGH PRESSURE FLUIDS HAZARD	5	<b>TROUBLESHOOTING</b>	<b>17</b>
<b>INTRODUCTION</b>	<b>6</b>	<b>APPENDIX</b>	<b>18</b>
APPLICATION	6	BOLT TORQUE	18
USING THIS MANUAL	6	ENGLISH TORQUE SPECIFICATIONS	18
TERMINOLOGY	6	METRIC TORQUE SPECIFICATIONS	19
DEFINITIONS	6	<b>WARRANTY</b>	<b>20</b>
OWNER ASSISTANCE	6	<b>PARTS ILLUSTRATION</b>	<b>21</b>
SERIAL NUMBER PLATE	6	<b>VAM FLAIL MOWER PARTS LIST</b>	<b>22</b>
<b>ASSEMBLY AND SET-UP</b>	<b>7</b>		
TRACTOR REQUIREMENTS	7		
PACKING DESCRIPTION	7		
ASSEMBLY	9		

## SPECIFICATIONS

Model	VAM48	VAM60	VAM65
Power Required	25-50 hp	25-60 hp	30-60 hp
Working Width	48 in	60 in	65 in
Overall Width	56 in	64 in	72 in
Blade Ground Clearance	0.65 in-2 in		
Max. Cutting Diameter	1.5 in		
Offset Distance From The Center (Maximum)	69 in	77 in	85 in
Tilt-Up Angle	90°		
Tilt-Down Angle	60°		
Number Of Blades	20	24	28
Blade Type	Hammer		
Size of Blades	3.5x3.2x1.6 in		
Blade Weight	0.9 lbs		
Blade Material	Cast Steel		
Rotor Bearing	SKF Bearing		
Rotor Diameter	4.3 in		
Blade Swing Diameter	14 in		
Rotor Thickness	0.3 in		
Rotor Shaft Speed	2356 rpm		
Hydraulic Fittings Size	G1/2 in		
Hydraulic Hoses Quantity	4		
Drive Type	Belt Drive		
Spline End	1.375 in Z6		
Driveline Shaft Length	T6-LF-63 With Shear Bolt; 63-77 in [05B-1600]		
PTO Shaft Speed	540 rpm		
Deck Thickness	0.16 in		
Side Plate Thickness	0.25 in		
3-Point Hitch	CAT 1		
Gearbox Oil Type	85W-90		
Number of Belts	3		
Belt Size	V Belt 17x991		
Finish	Powder Coating		
Warranty	1 Year		
Dimensions (L x WxH)	56x27.5x28 in	64 x 27.5 x 28in	72 x 27.5 x 28 in
Weight (N.W./G.W.)	613/696 lbs	673/738 lbs	701/820 lbs

**SAFETY SIGNS**

The rating plate on your machine may show symbols. These represent important information about the product or instructions on its use.

**⚠ WARNING**

The PTO Driveline **MUST** be measured and cut (if required) as per the Owner's Manual. Failure to do so will result in damage to both the tractor and the implement.

**⚠ DANGER**



**ROTATING DRIVELINE CONTACT CAN CAUSE DEATH KEEP AWAY!**

**DO NOT OPERATE WITHOUT :**

- All driveline guards, tractor, and equipment shields in place.
- Drivelines securely attached at both ends.
- Driveline guards that turn freely on driveline.

**⚠ DANGER ⚠**



**High Pressure Fluid Hazard.**  
High pressure fluid leak will pierce skin. Release pressure before working on system. Detect leaks with wood or cardboard. Wear sturdy gloves and goggles. NEVER use fingers.  
Fluid injected in skin must be surgically removed by trained doctor immediately or gangrene will result.  
Fluid injected into skin will injure or kill.

**⚠ WARNING**

**To Prevent Serious Injury Or Death:**

- Read and understand Operator's manual before using.
- Do not permit riders on the tractor or mower. Never carry child on tractor seat.
- Operate with guards installed and in good condition.
- Operate only with tractor equipped with ROPS and seatbelts.
- Keep away from moving parts.
- Stop engine, set brake and wait for all moving parts to stop before dismounting.
- Be sure lights and reflectors required by law are clean and in good working order before transporting.
- Do not allow children to operate mower.
- Travel with SMV and lights that follow local codes.
- Clean debris from mowing area.
- Do not operate in the raised position.
- Support securely before working beneath unit.
- Review safety instructions annually.

**⚠ WARNING**

**ENGAGE TRACTOR CLUTCH SLOWLY DURING START UP OR DAMAGE WILL OCCUR. KEEP PTO SHAFT WITH 25° OF LEVEL DURING OPERATION.**

**⚠ DANGER**

**GUARD MISSING WHEN THIS IS VISIBLE DO NOT OPERATE ENTANGLEMENT HAZARD**

**⚠ DANGER ⚠**



**ROTATING KNIVES HAZARD**

To prevent serious injury or death from rotating knives:

- DO NOT go under frame when rotor is turning or engine is running. Keep others away.
- Disconnect & lockout power source BEFORE adjusting or servicing.
- Keep hands, feet, hair, and clothing away from moving parts.

**⚠ WARNING**



**BELT DRIVE: HAND AND ARM ENTANGLEMENT HAZARD.**

Do not open or remove safety shields while engine is running.

**LIFT POINT**



**⚠ DANGER! STAY BACK 150 FEET AT ALL TIMES**

**⚠ WARNING! DO NOT MOW IN REVERSE OR DAMAGE WILL OCCUR TO YOUR MOWER!**

**⚠ CAUTION**



**GREASE**

**⚠ WARNING**



Read and understand operators manual before using this machine.

**⚠ CAUTION** To avoid Injury or Machine Damage: \*Operate only with 540 rpm PTO

**540 RPM ONLY**

**⚠ WARNING**



**PINCH POINT HAZARD Keep clear**

**⚠ WARNING**



**HIGH PRESSURE FLUID HAZARD**

Relieve pressure before disconnecting lines. Do Not use hands to check for leaks. Consult physician immediately if skin penetration occurs.

**⚠ WARNING**



**FLYING OBJECTS HAZARD Keep clear.**

**⚠ DANGER**



**ROTATING BLADES KEEP HANDS AWAY**

## IMPORTANT SAFETY INFORMATION

### SAFETY AT ALL TIMES

Thoroughly read and understand the instructions given in this manual before operation. Refer to the "Safety Decal", read all instructions noted on them.

Do not allow anyone to operate this equipment who has not fully read and comprehended this manual and who has not been properly trained in the safe operation of the equipment.

- Operator should be familiar with all functions of the unit.
- Operate implement from the driver's seat only.
- Make sure all guards and shields are in place and secured before operating the implement.
- Do not leave tractor or implement unattended with engine running.
- Dismounting from a moving tractor could cause serious injury or death.
- Do not stand between tractor and implement during hitching.
- Keep hands, feet, and clothing away from power-driven parts.
- Wear snug fitting clothing to avoid entanglement with moving parts.
- Watch out for wires, trees, etc., when raising implement. Make sure all persons are clear of working area.
- Turning tractor too tight may cause implement to ride up on wheels. This could result in injury or equipment damage.

### LOOK FOR THE SAFETY ALERT SYMBOL

The SAFETY ALERT SYMBOL indicates there is a potential hazard to personal safety involved and extra safety precaution must be taken. When you see this symbol, be alert and carefully read the message that follows it. In addition to design and configuration of equipment, hazard control and accident prevention are dependent upon the awareness, concern, prudence and proper training of personnel involved in the operation, transport, maintenance and storage of equipment.

### BE AWARE OF SIGNAL WORDS

A signal word designates a degree or level of hazard seriousness. The signal words are:

#### DANGER



Indicates an imminently hazardous situation which, if not avoided, will result in death or serious injury. This signal word is limited to the most extreme situations, typically for machine components that, for functional purpose, cannot be guarded.

#### WARNING



Indicates a potentially hazardous situation which, if not avoided, could result in death or serious injury, and includes hazards that are exposed when guards are removed. It may also be used to alert against unsafe practices.

#### CAUTION



Indicates a potentially hazardous situation which, if not avoided, may result in minor or moderate injury. It may also be used to alert against unsafe practices.

### FOR YOU PROTECTION

- Thoroughly read and understand the "safety label" section, read all instructions noted on them.

### SHUTDOWN AND STORAGE

- Lower machine to ground, put tractor in park, turn off engine, and remove the ignition key.
- Detach and store implements in a area where children normally do not play. Secure implement by using

### USE SAFETY LIGHTS AND DEVICES

- Slow moving tractors, self-propelled equipment, and towed implements can create a hazard when driven on public roads. They are difficult to see, especially at night.
- Flashing warning lights and turn signals are recommended whenever driving on public roads. Use lights and devices provided with implement.

## TRANSPORT MACHINERY SAFELY

- Comply with state and local laws.
- Maximum transport speed for implement is 20 mph. Do not exceed. Never travel at a speed which does not allow adequate control of steering and stopping. Some rough terrain require a slower speed.
- Sudden braking can cause a towed load to swerve and upset. Reduce speed if towed load is not equipped with brakes.
- Use the following maximum speed - tow load weight ratios as a guideline: 20 mph when weight is less than or equal to the weight of tractor. 10 mph when weight is double the weight of tractor.
- **IMPORTANT:** Do not tow a load that is more than double the weight of tractor.

## KEEP RIDERS OFF MACHINERY

- Riders obstruct the operator's view, they could be struck by foreign objects or thrown from the machine.
- Never allow children to operate equipment.

## PRACTICE SAFE MAINTENANCE

- Understand procedure before doing work. Use proper tools and equipment. refer to Operator's Manual for additional information.
- Work in a clean dry area.
- Lower the implement to the ground, put tractor in park, turn off engine, and remove key before performing maintenance.
- Allow implement to cool completely.
- Do not grease or oil implement while it is operation.
- Inspect all parts. Make sure parts are in good condition and installed properly.
- Remove buildup of grease, oil or debris.
- Remove all tools and unused parts from implement before operation.

## PREPARE FOR EMERGENCIES

- Be prepared if a fire starts.
- Keep a first aid kit and fire extinguisher handy.
- Keep emergency numbers for doctor, ambulance, hospital and fire department near phone.

## WEAR PROTECTIVE EQUIPMENT

- Protective clothing and equipment should be worn.
- Wear clothing and equipment appropriate for the job. Avoid loose fitting clothing.

- Prolonged exposure to loud noise can cause hearing impairment or hearing loss. Wear suitable hearing protection such as earmuffs or earplugs.
- Operating equipment safely requires the full attention of the operator. Avoid wearing radio headphones while operating machinery.

## AVOID HIGH PRESSURE FLUIDS HAZARD

- Escaping fluid under pressure can penetrate the skin causing serious injury.
- Avoid the hazard by relieving pressure before disconnecting hydraulic lines.
- Use a piece of paper or cardboard, not body parts, to check for suspected leaks. Wear protective gloves and safety glasses or goggles when working with hydraulic systems.
- If an accident occurs, see a doctor immediately. Any fluid injected into the skin must be treated within a few hours or gangrene may result.

---

## INTRODUCTION

---

MechMaxx welcomes you to the growing family of new product owners. This implement has been designed with care and built by skilled workers using quality materials. Proper assembly, maintenance, and safe operating practices will help you get years of satisfactory use from the machine.

### APPLICATION

The Flail Mowers are designed for Category 1- three point hitch or Quick-Hitch System mounting. These Fixed Bar Flail Mowers are ideal for ripping, leveling, finish grading, and backfilling applications at feedlots, outdoor arenas, building sites, and maintenance operations on farm and ranch lanes or roadways.

### USING THIS MANUAL

- This Operator's Manual is designed to help familiarize you with safety, assembly, operation, adjustments, troubleshooting, and maintenance. Read this manual and follow the recommendations to help ensure safe and efficient operation.
- The information contained within this manual was current at the time of printing. Some parts may change slightly to assure you of the best performance.
- To order a new Operator's or Parts Manual contact your authorized dealer.

### TERMINOLOGY

" Right" or "Left" as used in this manual is determined by facing the direction the machine will operate while in use unless otherwise stated.

### DEFINITIONS

Note :A special point of information that the operator must be aware of before continuing.

Important: A special point of information related to its preceding topic. The intention is that this information should be read and noted before continuing.

### OWNER ASSISTANCE

The Warranty Registration card should be filled out by the dealer at the time of purchase. This information is necessary to provide you with quality customer service. If customer service or repair parts are required contact a

dealer. A dealer has trained personnel, repair parts and equipment needed to service the machine. The parts on your machine have been specially designed and should only be replaced with genuine parts.

### SERIAL NUMBER PLATE

For prompt service always use the serial number and model number when ordering parts from your dealer. Be sure to include your serial and model numbers in correspondence also.

**ASSEMBLY AND SET-UP**

**TRACTOR REQUIREMENTS**

This mower is designed with a 3-Point category I hitch. Tractor horse power rating should not exceed 80 PTO horse power.

**PACKING DESCRIPTION**

1. Remove and check  
Remove the packing, check goods without defect and omission.

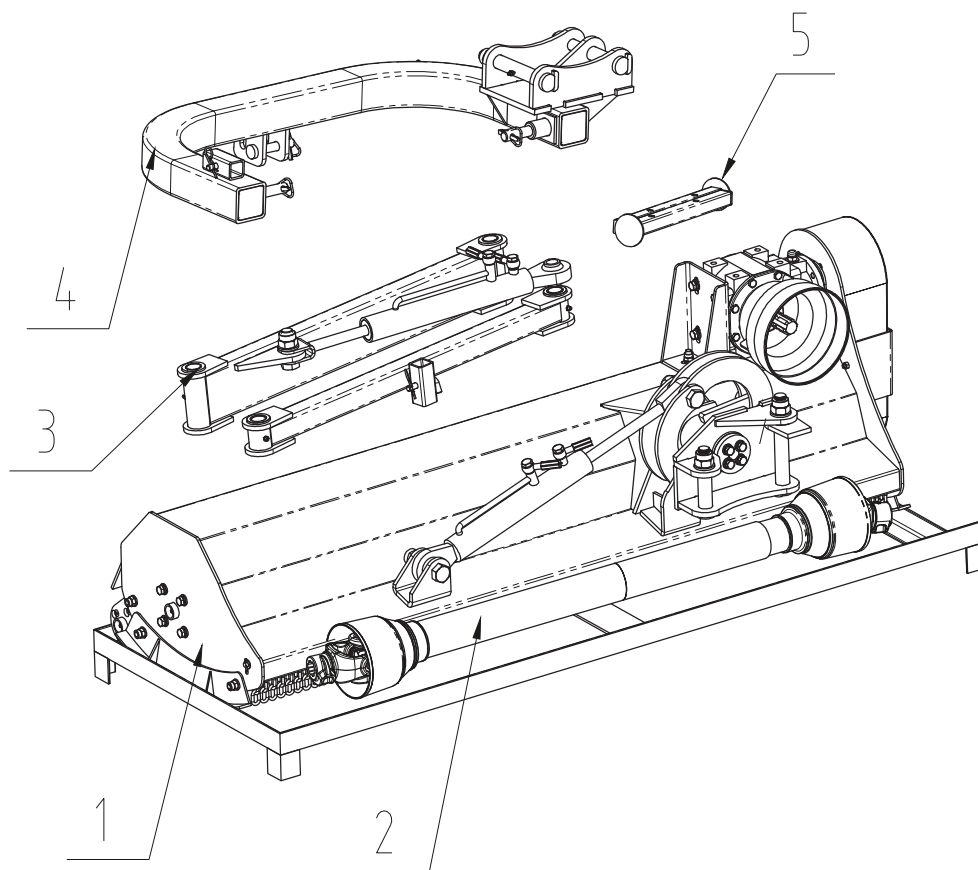

Figure 1-1: The Mower and Accessory in Package

**2. Packing List**

The detailed packing list of the mower and accessory as the following table.

Item	Description
1	Main body of the mower
2	W-02-05B-1600A with safety drive shaft
3	Swing arms sub-assembly
4	Suspension components
5	Support Leg assembly

The detailed description of main body of the mower and fittings

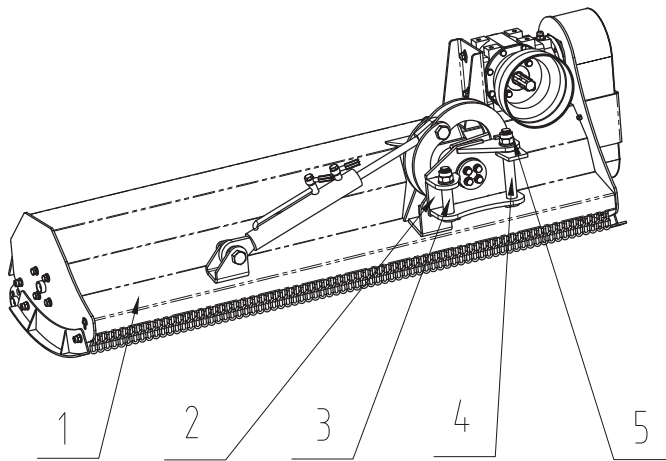

Item	Description
1	Main body of the mower
2	AGL165COS.8A Flip Frame Welding Assembly
3	AGL165.6 short shafts
4	AGL165.2AGL165.2B
5	B-G00889A-24 Nut M24

Figure 1-2: Main Body of The Mower and Fittings

The detailed description of swing arms sub-assembly and fittings

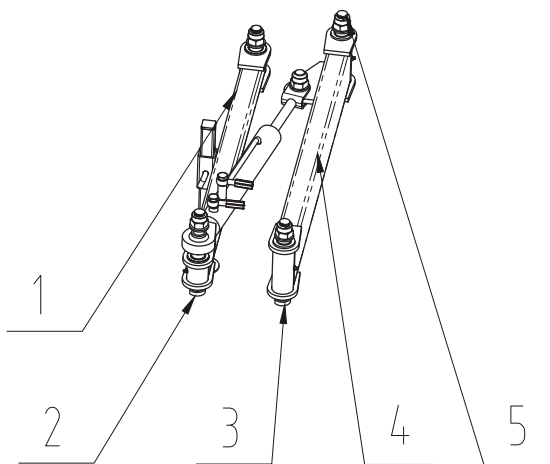

Item	Description
1	AGL165.4 Small Rotating Arm Welding Assembly
2	AGL165.2B Long Sales 2
3	AGL165.2 Long Sales
4	AGLJA125.3 Large Rotating Arm Welding Assembly
5	B-G00889A-24 Nut M24

Figure 1-3: Swing Arms Sub-Assembly and Fittings

The detailed description of hitch tube amendment and fittings

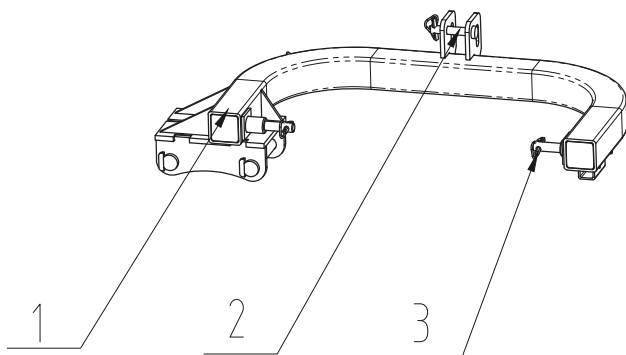

Item	Description
1	AGL165COS.1A Suspension Frame Welding Assembly
2	Hanging pin on NCM175.17
3	B-G043290-10 locking pin 10

Figure 1-4: Hitch Tube Amendment and Fittings

The detailed description of Support Leg Assembly

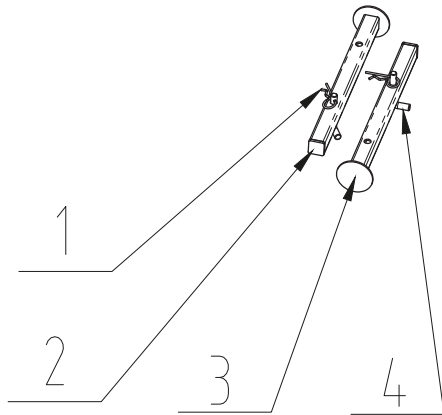

Item	Description
1	EFGC125.110 R Sales 3.2
2	W-08-F40 square rubber cover 40
3	AGL165.5 support foot welding assembly
4	EFGC175.37 support foot pin

Figure 1-5: Support Leg Assembly

## INSTALLATION WIZARD

The installation wizard will guide you to finish the final assembly of your new mower easily.

### 1. TOOL REQUIRED

- Air impact wrench with 46mm sleeve
- T type socket wrench 13mm
- T type socket wrench 18mm

### 2. TORQUE APPLICATION

Refer to bolt torque in Section 7 Appendix.

### 3. ASSEMBLY

#### Step1: Installing Swing Arms Sub-Assembly

Remove the packaging of swing arms sub-assembly and fittings. Push swing arms sub-assembly into the overturning bracket assembly as shown in figure1-6. Fix it with 2pcs of swing arm pins-longer, 2pcs of knockout M30x2. Tighten knockout completely

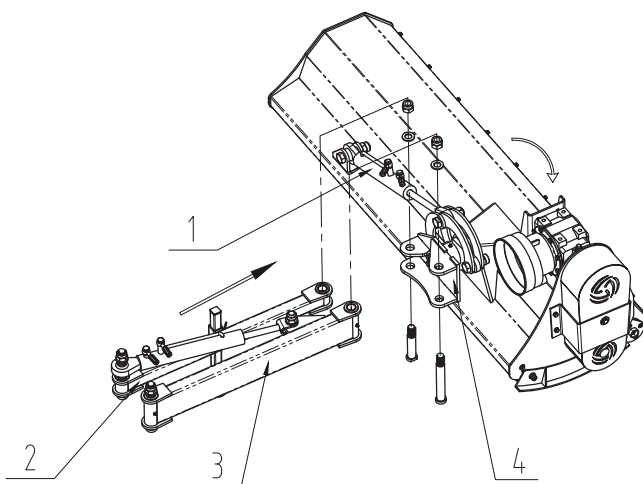

Item	Description
1	AGL165.12A Flip Cylinder
2	AGL165.4 Small Rotating Arm Welding Assembly
3	AGLJA125.3 Large Rotating Arm Welding Assembly
4	AGL165COS.8A Flip Frame Welding Assembly

Figure 1-6: Installing Swing Arms Sub-Assembly

### Step2: Installing Hitch Tube Amendment and Fittings

Remove the packaging of hitch tube amendment and fittings. Fix hitch tube amendment to swing arms sub-assembly with 1pcs of swing arm pin-shorter, 1pcs of knockout M30x2. Tighten knockout completely.

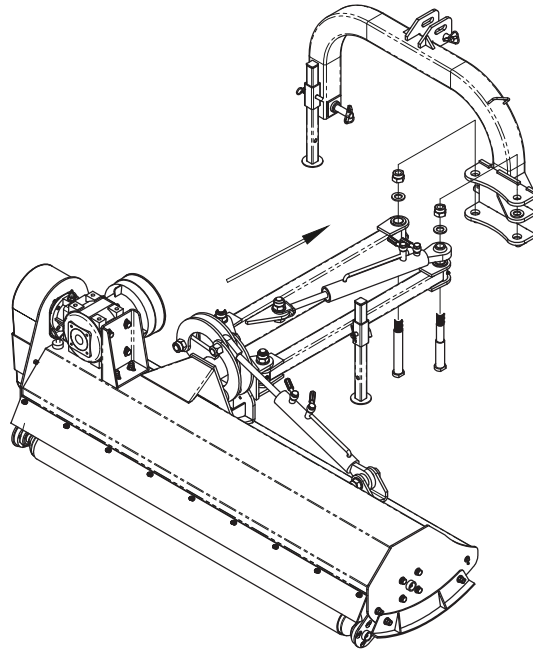

Figure 1-7: Installing Hitch Tube Amendment and Fittings

### Step3: Installing Rake Sub-Assembly

Remove the packaging of rake sub-assembly. Insert rake amendment-longer into the tube on swing arm amendment-I as well as rake pin and insert R pin into the hole on rake pin. Insert rake short-termism into the tube on hitch tube amendment as well as rake pin and insert R pin into the hole on rake pin. Pass all oil pipes through the guide ring and fix them with oil pipe clamps.

Note: The length of oil pipes between oil cylinders and pipe clamps shall be reserved with allowance to prevent oil pipes from being damaged during swing arms moving left and right and main body of the mower turning up and down.

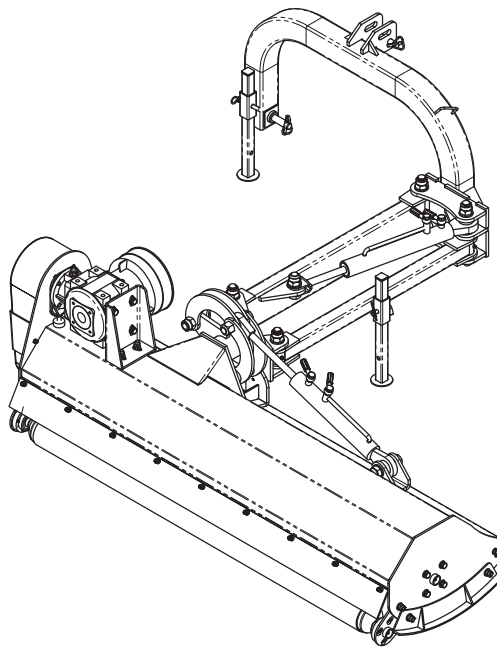

Figure 1-8: Installing Rake Sub-Assembly and Oil Pipes Fixation

**WARNING**

Fill the gearbox with proper amount of gear oil before operation. Ensure that the height of the rotation axis from the ground is greater than 700mm, otherwise one side of the mower will touch the ground in advance, resulting in damage to the connecting plate and hinging bracket. Refer to figure 1-6.

## TRACTOR HOOK-UP

1. Be certain that tractor draw bar will not interfere. Move draw bar ahead or remove if required. Draw bar should also be checked for clearance when unit is being raised for the first time.
2. Align lower link arms of tractor to hitch clevises on mower. Insert lower hitch pins into lower ball swivels and attach link pins.
3. Attach tractor top link to upper floating hitch on mower with pin supplied. Secure with lock pin.
4. Adjust tractor top link in or out to place upper hitch pin vertically above or slightly behind lower hitch pins to allow mower flotation. The mower should be run with the back 15 degrees lower than the front.

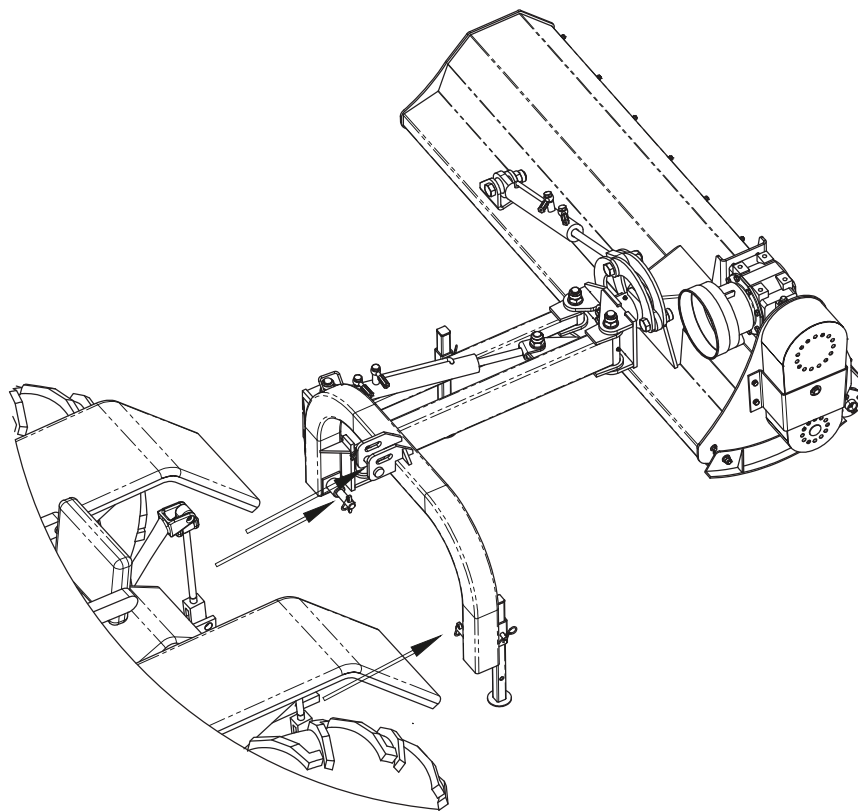

Figure 1-9: Tractor Hook-up

## DRIVELINE INSTALLATION

1. Slide driveline end with extended safety cone over spline shaft of gearbox and secure with attaching device.
2. Slide driveline over tractor's spline PTO shaft and secure with locking device of driveline.
3. Driveline should now be moved back and forth to ensure that it is secure on the PTO shaft of the tractor and mower gearbox.
4. Attach chain from the driveline shield to one of the upper hitch braces to ensure that the shield does not rotate.

5. Should driveline require shortening:
  - a. Hold the half-shafts next to each other in the shortest working position and mark them.
  - b. Shorten inner and outer guard tubes equally.
  - c. Shorten inner and outer sliding profiles by the same length as the guard tubes.
  - d. Proper overlap is a minimum of one-half the length of each tube, with both tubes being of equal length.
  - e. Round off all sharp edges and remove burrs. Grease sliding profiles.



CAUTION

**Tractor PTO shield and all mower guards must be always in place during operation!**

## OPERATING INSTRUCTIONS

### TRANSPORTING

NOTE: Always disengage PTO before raising mower to transport position.

1. When raising the mower to transport position, be sure that driveline does not contact tractor or mower. Adjust and set the tractor's 3-point hitch lift height so that the driveline does not contact mower deck in the fully raised position.
2. Be sure to reduce tractor ground speed when turning, leaving enough clearance so that the mower does not contact buildings, trees, or fences.
3. Select a safe ground travel speed when transporting from one area to another. When traveling on roadways, transport in such a way that faster moving vehicles may pass safely.
4. When traveling over rough or hilly terrain, shift tractor to a lower gear.



CAUTION

**When traveling on public roads, whether at night or during the day, use accessory lights and devices for adequate warning to operators of other vehicles. Comply with all Federal, State, and local laws.**

### MOWING INSTRUCTIONS

1. Clear area to be mowed of objects and debris that might be picked up and thrown by the mower blades.
2. Grass is best cut when it is dry. Mowing wet grass can cause plugging resulting in grass clumps behind the mower.
3. Grass should be mowed frequently as shorter clippings deteriorate faster.
4. If mowing extremely tall grass, it is best to raise cutting height and mow the area, then lower cutting height and mow a second time at the desired height.

### OPERATING INSTRUCTIONS

Proper servicing and adjustments are the key to the long life of any machine. With careful and systematic inspection of the mower, costly maintenance, time and repair can be avoided.

Before beginning to mow, the following inspection should be performed:

1. Check oil level in gearbox.
2. Check that all plugs in gearbox have been replaced and tightened properly.
3. Be sure all mower knives, bolts and nuts are tight.
4. Be certain all guards and shields are in place and secure.
5. Grease driveline shaft and all other grease fittings.
6. Clear area to be mowed of rocks, branches and other foreign objects.
7. Lower mower to ground. Set tractor throttle at approximately 1/4 open. Engage PTO to start blades rotating.
8. Operate with 540 rpm PTO tractor.
9. At first begin mowing at a slow forward speed and shift up until the desired speed is achieved - maintaining 540 PTO rpm.
10. Mower knives will cut better at a faster blade speed than at reduced throttle.
11. After mowing the first 50 feet, stop and check to see that the mower is adjusted properly.
12. Do not make sharp turns or attempt to back up while mower is on the ground.
13. Do not engage PTO with mower in the fully raised position. Do not engage PTO at full throttle.

## ADJUSTMENTS

### LEVELING THE MOWER

NOTE: Tractor and mower should be on level ground. Leveling can be adjusted at the tractor's 3-point arms and center link.

### CUTTING HEIGHT ADJUSTMENT

The machines cutting height depends upon the position of the rear roller.

1. Remove the bolts that fix the roller on both sides.
2. Lift or lower both sides of roller in equal measurements.
3. Replace bolts and re-tighten.

### 3-POINT HITCH ADJUSTMENTS

The 3-point hitch system on this mower has been designed for front to back flotation when mowing on uneven terrain. Adjust tractor's top center link to place the upper hitch pin vertically above or slightly behind the lower hitch pins. The mower should be run with the back 15 degrees lower than the front. The hitch can also be adjusted from side to side by turning the adjustment handle. Turn handle until you have achieved your desired location.



**CAUTION** Excessive tension on the belt may lead to premature failure of belt and drive components. Excessive tension on the belt may also lead to a safety hazard to the operator or bystanders.



**CAUTION** Engage parking brake, shut off tractor, remove key and disengage PTO before making any height adjustments!



**CAUTION** Belt drive system under spring tension; use care to avoid bodily harm!

The Belt tension should be checked after the first 20 hours of use. And then every 40 hours of use.

1. Tension on the belt can be adjusted with the belt tension bolt. Turn the bolt until desired tension is achieved. When the belt has the correct tension the gearbox should be adjusted so that the gearbox extension is running straight (parallel) with the flail mower. Loosen bolts at the bottom of the gearbox and move gearbox until gearbox extension is running straight.
2. Excessive tension on the belt may lead to premature failure of belt and drive components.

## MAINTENANCE AND LUBRICATION

### MAINTENANCE

Proper servicing and adjustment is the key to the long life of any farm implement. With careful and systematic inspection, you can avoid costly maintenance, time and repair.



**CAUTION**

**For safety reasons, each maintenance operation must be performed with tractor PTO disengaged, mower lowered completely to ground and tractor engine shut off with ignition key removed.**

- After using the mower for several hours, check all bolts to be sure they are tight and check drive belt tension.
- Replace any worn, damaged or illegible safety decals by obtaining new decals from dealer.

### KNIFE REPLACEMENT

**IMPORTANT:** Make sure that the knife is the same length as the others on the mower. This will keep the rotor rotation balanced.

1. Remove bolt and nut.
2. Remove old knife.
3. Install new knife and existing bolt.
4. Secure with nut.

### V-BELT INSTALLATION

Belt drive system under spring tension; use care to avoid bodily harm!

1. Remove belt guard fender and belt cover.
2. Disengage belt tension by loosening belt tension bolt until belt can be removed.
3. With tension relieved from belt remove old belt from pulleys.
4. Tighten belt tension bolt.
5. Reinstall belt guard and belt guard fender.

### STORAGE

At the end of the working season or when the mower will not be used for a long period, it is good practice to clean off any dirt or grease that may have accumulated on the mower and any of moving parts.

1. Clean as necessary.
2. Check knives for wear and replace if necessary.
3. Inspect mower for loose, damaged or worn parts and adjust or replace as needed.
4. Store unit inside if possible for longer life.
5. Repaint parts where paint is worn or scratched to prevent rust.
6. Replace all damaged or missing decals.

### LUBRICATION

Driveline Shaft U-Joints

	 <b>25 HOURS</b>
--	---

Type of Lubrication: Multi-purpose Grease

Roller Bearing (Both Ends)

	 <b>25 HOURS</b>
--	---

Type of Lubrication: Multi-purpose Grease

Cutter Rotor Bearing (Both Ends)

	 <b>25 HOURS</b>
--	---

Type of Lubrication: Multi-purpose Grease

Gearbox

	 <b>AS REQUIRED</b>
--	--

Type of Lubrication: SAE 90W Gear Lube

Check oil level in gearbox by removing the plug located on the right hand side. Oil should be level with bottom of plug hole. Add oil if necessary by removing top fill plug and side plug. Add oil until it flows from side plug hole. Do not overfill!

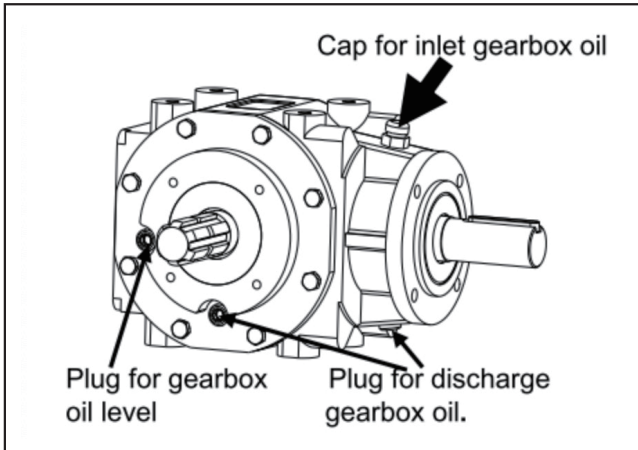

IMPORTANT: Mower should be level when checking oil in gearbox!

### Driveline Profiles



Type of Lubrication: Multi-purpose Grease

## TROUBLESHOOTING

Problem	Solution
 <b>CAUTION</b>	<b>Do not try to clean rear discharge area when mower is running. Bodily harm may occur!</b>
Belt slipping	Unplug and clean mower deck.
	Remove belt guard shields and clean sheaves.
	Replace belt.
Patches of uncutgrass	Mow at full throttle (540 PTO rpm), check PTO speed and tractor engine.
	Shift transmission to a lower gear.
	Tighten belts.
	Replace missing knives.
Excessive vibration	Replace knives.
	Replace drive belt.
	Replace pulleys or align.
	Remove belt guard shields & clean debris from belt area & sheaves.
Gearbox noisy	Check lubricant level.
Knives scalping grass	Raise cutting height by adjusting roller.
	Change mowing pattern.
	Reduce speed turns.
Uneven cut	Shift to a lower gear.
	Level mower.
	Replace missing knives.
Tractor loaded down by mower	Mow at full throttle (540 PTO rpm).
	Shift to a lower gear.
	Clean mower.

## APPENDIX

### Bolt Torque

The tables shown below give correct torque values for various bolts and cap screws. Tighten all bolts to the torques specified unless otherwise noted. Check tightness of bolts periodically, using bolt torque chart as a guide. Replace hardware with the same strength bolt.

### ENGLISH TORQUE SPECIFICATIONS

Bolt Diameter	Bolt Torque					
	SAE 2		SAE 5		SAE 8	
	N.m	lb-ft	N.m	lb-ft	N.m	lb-ft
1/4"	8	6	12	9	17	12
5/16"	13	10	25	19	36	27
3/8"	27	20	45	33	63	45
7/16"	41	30	72	53	100	75
1/2"	61	45	110	80	155	115
9/16"	95	60	155	115	200	165
5/8"	128	95	215	160	305	220
3/4"	225	165	390	290	540	400
7/8"	230	170	570	420	880	650

**METRIC TORQUE SPECIFICATIONS**

Bolt Diameter	Bolt Torque			
	8.8		10.9	
	N.m	lb-ft	N.m	lb-ft
M3	0.5	0.4	1.8	1.3
M4	3	2.2	4.5	3.3
M5	6	4	9	7
M6	10	7	15	11
M8	25	18	35	26
M10	50	37	70	52
M12	90	66	125	92
M14	140	103	200	148
M16	225	166	310	229
M20	435	321	610	450
M24	750	553	1050	744
M30	1495	1103	2100	1550
M36	2600	1917	3675	2710

Torque figures indicated above are valid for non-greased or non-oiled threads and heads otherwise specified. Therefore, do not grease or oil bolts or cap screws unless otherwise specified in this manual. When using locking elements, increase torque values by 5%.

---

## WARRANTY

---

Mechmaxx warrants to the original purchaser that this product will be free from defects in material and workmanship beginning on the date of purchase by the end user according to the following schedule when used as intended and under normal service and conditions for personal use. Overall Unit and Drive line: One year Parts and Labor Gearbox: One year on all components. Blades and Belts: Considered wear items. This warranty covers the replacement of any defective part by MechMaxx and the installation of that part by an authorized dealer. It does not cover common wear items, including blades, belts, and tines. MechMaxx reserves the right to inspect any part claimed to be defective before issuing a replacement. MechMaxx reserves the right to inspect any equipment or parts which are claimed to have been defective in material or workmanship. This warranty does not apply to any part or product which in MechMaxx's judgment shall have been misused or damaged by accident or lack of normal maintenance or care, or which has been repaired or altered in a way which adversely affects its performance or reliability, or which has been used for a purpose for which the product not designed. Misuse also specifically includes failure to properly maintain oil levels, grease points, and drive line shafts. Claims under this warranty must be made to the dealer which originally sold the product and all warranty adjustments must be made through such dealer. MechMaxx reserves the right to make changes in materials or design of the product at any time without notices. This warranty shall not be interpreted to render MechMaxx liable for damages of any kind, direct, consequential, or contingent to property. Furthermore, MechMaxx shall not be liable for damages resulting from any cause beyond its reasonable control. This warranty does not extend to loss of crops, any expense or loss for labor, supplies, rental machinery or for any other reason. No other warranty of any kind whatsoever, express or implied, is made with respect to this sale; and all implied warranties of merchantability and fitness for a particular purpose which exceed the obligations set forth in this written warranty are hereby disclaimed and excluded from this sale.

PARTS ILLUSTRATION

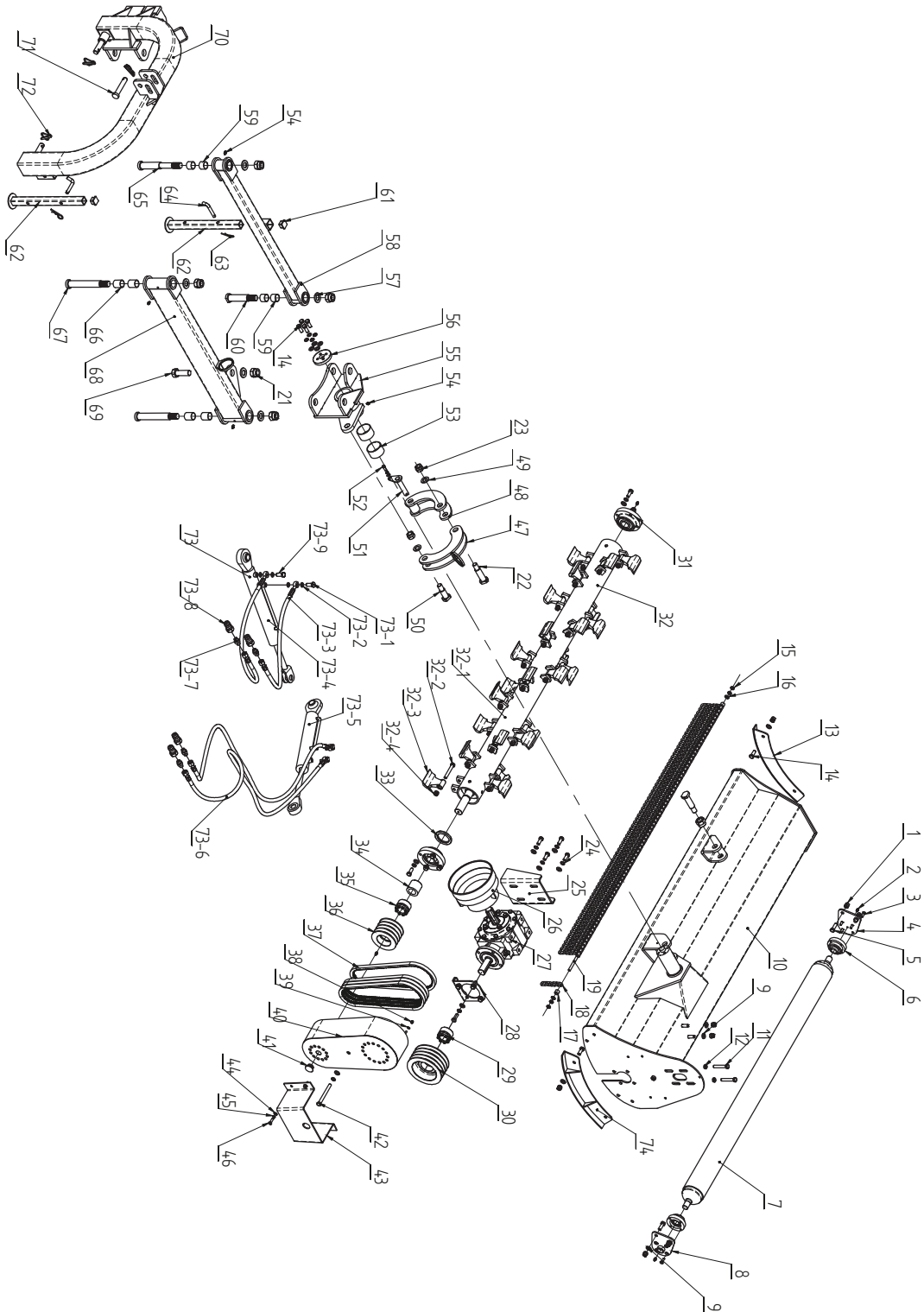

## VAM FLAIL MOWER PARTS LIST

No.	PART NUMBER	DESCRIPTION	QTY
1	B-G00889A-12	Nut M12	8
2	B-J07940A-8*1A	Oil cup M8*1-304	4
3	B-G00070C-8*25	Bolt M8*25	8
4	AGL165.19	Roller hanging plate welding weldment (R)	1
5	B-G057830-12*35	Bolt M12*35	2
6	EFGC175.19B	UC205 bearing assembly	2
7	AGL125.21	Roller weldment	1
	AGL145.21		1
	AGL165.21		1
8	AGL165.20	Roller hanging plate welding weldment (L)	1
9	B-G00097A-12	Plain washer 12	29
10	AGL125.13	Hood welding assembly	1
	AGL145.13		1
	AGL165.13		1
11	B-G057830-12*70	Bolt M12*70	2
12	GB/T6172.1	Nut M12	2
13	AGL165.15	Sliding plate welding assembly (L)	1
14	B-G057830-12*30	Bolt M12*30	24
15	B-G06172A-10	Nut M10	4
16	B-G00097A-10	Plain washer 10	21
17	LM180.15	Spacer sleeve	57
			66
			76
18	AGL165.30	chain	56
			65
			75
19	AGL125.25	Barrier hanging rod	1
	AGL145.25		1
	AGL165.25		1

No.	PART NUMBER	DESCRIPTION	QTY
21	B-G00889A-24	Locking nut M24	5
22	AGLJA125.25	AGLJA125.25	2
23	B-G00889A-20	Locking nut M20	3
24	B-G000930-12	Spring washer 12	21
25	AGL165.16	Gearbox assembly	1
26	FM150.120	Drive shaft cover	1
27	W-01-T101L	Gearbox (50HP)	1
28	AGL165.17	Gearbox adjustment plate welding assembly	1
29	B-J7934Z3-33*60	Swellable sleeve Z3-33*60	1
30	EFGC155.31	Big belt ptley	1
30	EFGC175.31		1
31	EFGC175.25A	Reverse installation of bearing UCU207	2
32	AGL125.22A	Knife shaft component	1
	AGL145.22A		1
	AGL165.22A		1
32-1	AGL125.22	Blade shaft welding assembly	1
	AGL145.22		1
	AGL165.22		1
32-2	B-G057820-12*80	Bolt M12*80	20
			24
			28
32-3	AGL165.39	Hammers(400g)	20
			24
			28
32-4	B-G00889A-12	Nut M12	20
			24
			28
33	B-G13871A-FB55*80*8	Oil seal FB55*80*8	1
34	EFGC155.26	Oil-sealing sleeve	1
	EFGC175.26		1
35	B-J7934Z3-35*60	Swellable sleeve Z3-35*60	1

No.	PART NUMBER	DESCRIPTION	QTY
36	EFGC155.27	Small belt ptiley	1
	EFGC175.27		1
37	GB/T12732	Tooth shaped V-belt AV17 * 991	3
			4
38	B-G00889A-6	Nut M6	1
39	B-G00097A-6	Washer 6	1
40	AGL145.18SDMH	Pulley cover weldment	1
	AGL165.18SDMH		1
41	W-08-Y25	Circular rubber cover with a diameter of 25	1
42	B-G057820-12*110	Bolt M12*110	1
	B-G057820-12*130	Bolt M12*130	1
43	AGL165.24A	Belt pulley cover guard	1
	AGL165.24B		1
44	B-G00097A-8	Plain washer 8	5
45	B-G000930-8	Spring washer 8	5
46	B-G057830-8*25	Bolt M8*25	4
47	AGLJA125.10	Upper lunar plate welding assembly	1
48	AGLJA125.11	Lower Moon Plate Weldment	1
49	B-G057820-24*100	Bolt M24*100	1
50	B-G057830-24*80	Bolt M24*80	1
51	AGL165.23	Pin welding assembly	1
52	B-G057830-8*20	Bolt M8*20	1
53	W-06-SF-2-6340	Bushing SF-2-68 * 63 * 40	2
54	B-J07940A-8*1A	Straight-through oil filler cup M8 * 1	5
55	AGL165COS.8A	Tilting and welding assembly	1
56	AGL165.9	round clamp	1
57	B-G00097A-24	Plain washer 24	6
58	AGL165.4	Small rotating arm welding assembly	1
59	W-06-SF-2-3025	Bushing SF-2-34 * 30 * 25	4
60	AGL165.6	Short pin	1
61	W-08-F40	Square rubber cover □ 40	2
62	AGL165.5	Leg welding assembly	2

No.	PART NUMBER	DESCRIPTION	QTY
63	EFGC125.110	R pin 3.2	2
64	EFGC175.37	Supporting pin	2
65	AGL165.2B	Long pin 2	1
66	W-06-SF-2-3040	Bushing SF-2-34 * 30 * 40	4
67	AGL165.2	Long pin	2
68	AGLJA125.3	Big rotating arm welding assembly	1
69	B-G057830-24*70	Bolt M24*70	1
70	AGL165COS.1A	Hanging weldment	1
71	EFGC175.33	Upper suspension pin	1
72	B-G043290-10	Locking pin 10	3
73	AGL165.26	Hydraulic Components	1
73-1	AGL165COS.26B.3	Hinge bolt with throttle hole	2
73-2	B-J009820-12	Combination washer 12	8
73-3	AGL165.26-2	Swing cylinder oil pipe	2
73-4	AGL165.7A	Swing cylinder	1
73-5	AGL165.12A	Tilting cylinder	1
73-6	AGL165.26-1	Tilting cylinder oil pipe	2
73-7	W-05-GE10LR1/2ED	End straight connector G1/2-M16 * 1.5	4
73-8	B-G058620-L-G1/2	Quick change male connector G1/2	4
73-9	B-J009990-12*1.25*30	Hinge bolt M12 * 1.25 * 30	2
74	AGL165.14	Sliding plate welding assembly (R)	1

***MechMaxx***

[info@mechmaxx.com](mailto:info@mechmaxx.com)