

VBM 78/86 HEAVY DUTY FLAIL MOWER



Operator's Manual

MechMaxx

www.mechmaxx.com

TABLE OF CONTENTS

TABLE OF CONTENTS	1	ADJUSTMENTS	16
IMPORTANT SAFETY INFORMATION	2	LEVELING THE MOWER	16
SAFETY ALWAYS	2	CUTTING HEIGHT ADJUSTMENT	16
TRANSPORT MACHINERY SAFELY	2	3-POINT HITCH ADJUSTMENTS	16
SAFETY LABELS	4	BELT TENSION	16
INTRODUCTION	5	MAINTENANCE AND LUBRICATION	17
USING THIS MANUAL	5	MAINTENANCE	17
TERMINOLOGY	5	KNIFE REPLACEMENT	17
OWNER ASSISTANCE	5	V-BELT INSTALLATION	17
ASSEMBLY AND SET-UP	6	STORAGE	17
TRACTOR REQUIREMENTS	6	LUBRICATION	17
PACKING DESCRIPTION	6	SPECIFICATIONS & CAPACITIES	19
INSTALLATION WIZARD	10	TROUBLESHOOTING	20
TRACTOR HOOK-UP	13	APPENDIX	21
DRIVELINE INSTALLATION	14	WARRANTY	21
OPERATING INSTRUCTIONS	15	BOLT TORQUE	21
MUST ADD OIL BEFORE FIRST USE	15	ENGLISH TORQUE SPECIFICATIONS	21
TRANSPORTING	15	METRIC TORQUE SPECIFICATIONS	21
MOWING INSTRUCTIONS	15	PART BREAKDOWN LIST	22
OPERATING INSTRUCTIONS	15	PARTS LIST	24

IMPORTANT SAFETY INFORMATION

SAFETY ALWAYS

Thoroughly read and understand the instructions given in this manual before operation. Refer to the "Safety Decal", read all instructions noted on them.

Do not allow anyone to operate this equipment who has not fully read and comprehended this manual and who has not been properly trained in the safe operation of the equipment.

1. Operator should be familiar with all functions of the unit. Operate implement from the driver's seat only.
2. Make sure all guards and shields are in place and secured before operating the implement.
3. Do not leave tractor or implement unattended with engine running.
4. Dismounting from a moving tractor could cause serious injury or death.
5. Do not stand between tractor and implement during hitching.
6. Keep hands, feet, and clothing away from power-driven parts.
7. Wear snug fitting clothing to avoid entanglement with moving parts.
8. Watch out for wires, trees, etc., when raising implement. Make sure all persons are clear of working area.
9. Turning tractor too tight may cause implement to ride up on wheels. This could result in injury or equipment damage.

Look For the Safety Alert Symbol

The SAFETY ALERT SYMBOL indicates there is a potential hazard to personal safety involved and extra safety precaution must be taken. When you see this symbol, be alert and carefully read the message that follows it. In addition to design and configuration of equipment, hazard control and accident prevention are dependent upon the awareness, concern, prudence, and proper training of personnel involved in the operation, transport, maintenance and storage of equipment.

Be aware of signal words

A signal word designates a degree or level of hazard seriousness. The signal words are:



Indicates an imminently hazardous situation which, if not avoided, will result in death or serious injury. This signal word is limited to the most extreme situations, typically for machine components that, for functional purpose, cannot be guarded.



Indicates a potentially hazardous situation which, if not avoided, could result in death or serious injury, and includes hazards that are exposed when guards are removed. It may also be used to alert against unsafe practices.



Indicates a potentially hazardous situation which, if not avoided, may result in minor or moderate injury. It may also be used to alert against unsafe practices.

For your protection

Thoroughly read and understand the "safety label" section, read all instructions noted on them.

Shut down and storage

Lower machine to ground, put tractor in park, turn off engine, and remove the ignition key.

Detach and store implements in an area where children normally do not play. Secure implement by using blocks and supports.

Use safety lights and devices

Slow moving tractors, self-propelled equipment, and towed implements can create a hazard when driven on public roads. They are difficult to see, especially at night.

Flashing warning lights and turn signals are recommended whenever driving on public roads. Use lights and devices provided with implement.

TRANSPORT MACHINERY SAFELY

1. Comply with state and local laws.
2. Maximum transport speed for implement is 20 mph. Do not exceed. Never travel at a speed which does not allow adequate control of steering and stopping. Some rough terrain requires a slower speed.

3. Sudden braking can cause a towed load to swerve and upset. Reduce speed if towed load is not equipped with brakes.

4. Use the following maximum speed - tow load weight ratios as a guideline:

5. 20 mph when weight is less than or equal to the weight of tractor.

6. 10 mph when weight is double the weight of tractor.

7. **IMPORTANT:** Do not tow a load that is more than double the weight of tractor.

Keep riders off machinery.

Riders obstruct the operator's view, they could be struck by foreign objects or thrown from the machine.

Never allow children to operate equipment.

Practice safe maintenance

1. Understand procedure before doing work. Use proper tools and equipment. refer to Operator's

2. Manual for additional information.

3. Work in a clean dry area.

4. Lower the implement to the ground, put tractor in park, turn off engine, and remove key before performing maintenance.

5. Allow implement to cool completely.

6. Do not grease or oil implement while it is operation.

7. Inspect all parts. Make sure parts are in good condition and installed properly.

8. Remove buildup of grease, oil or debris.

9. Remove all tools and unused parts from implement before operation.

10. Prepare for emergencies

11. Be prepared if a fire starts.

12. Keep a first aid kit and fire extinguisher handy.

13. Keep emergency numbers for doctor, ambulance, hospital and fire department near phone.

Wear protective equipment.

1. Protective clothing and equipment should be worn.

2. Wear clothing and equipment appropriate for the job. Avoid loose fitting clothing.

3. Prolonged exposure to loud noise can cause hearing impairment or hearing loss. Wear suitable hearing protection such as earmuffs or earplugs.

4. Operating equipment safely requires the full attention of the operator. Avoid wearing radio headphones while operating machinery.

Avoid high pressure fluids hazard.

1. Escaping fluid under pressure can penetrate the skin causing serious injury.

2. Avoid the hazard by relieving pressure before disconnecting hydraulic lines.

3. Use a piece of paper or cardboard, not body parts, to check for suspected leaks. Wear protective gloves and safety glasses or goggles when working with hydraulic systems.

4. If an accident occurs, see a doctor immediately. Any fluid injected into the skin must be treated within a few hours or gangrene may result.

SAFETY LABELS

Your Flail Mower comes equipped with all safety labels in place. They were designed to help you safely operate your implement. Read and follow their directions.

1. Keep all safety labels clean and legible.
2. Replace all damaged or missing labels. To order new labels go to your nearest MECHMAXX dealer or visit our dealer locator at MECHMAXX.com.
3. Some new equipment installed during repair requires safety labels to be affixed to the replaced component as specified by MECHMAXX. When ordering new components make sure the correct safety labels are included in the request.
4. Refer to this section for proper label placement. To install new labels:
 - a. Clean the area the label is to be placed.
 - b. Spray soapy water on the surface where the label is to be placed.
 - c. Peel backing from label. Press firmly onto the surface.
 - d. Squeeze out air bubbles with the edge of a credit card.

⚠ WARNING ⚠

To Prevent Serious Injury Or Death:

- Read and understand Operator's manual before using.
- Do not permit riders on the tractor or mower. Never carry child on tractor seat.
- Operate with guards installed and in good condition.
- Operate only with tractor equipped with ROPS and seatbelts.
- Keep away from moving parts.
- Stop engine, set brake and wait for all moving parts to stop before dismantling.
- Be sure lights and reflectors required by law are clean and in good working order before transporting.
- Do not allow children to operate mower.
- Travel with SMV and lights that follow local codes.
- Clean debris from mowing area.
- Do not operate in the raised position.
- Support securely before working beneath unit.
- Review safety instructions annually.

⚠ DANGER

ROTATING DRIVELINE CONTACT CAN CAUSE DEATH KEEP AWAY! DO NOT OPERATE WITHOUT :

- All driveline guards, tractor, and equipment shields in place.
- Drivelines securely attached at both ends.
- Driveline guards that turn freely on driveline.

⚠ WARNING

BELT DRIVE: HAND AND ARM ENTANGLEMENT HAZARD.

Do not open or remove safety shields while engine is running.

⚠ CAUTION

⚠ WARNING

The PTO Driveline MUST be measured and cut (if required) as per the Owner's Manual. Failure to do so will result in damage to both the tractor and the implement.

⚠ DANGER

ROTATING BLADES KEEP HANDS AWAY

⚠ CAUTION To avoid Injury or Machine Damage: *Operate only with 540 rpm PTO

540 RPM ONLY

⚠ DANGER ⚠

ROTATING KNIVES HAZARD

To prevent serious injury or death from rotating knives:

- DO NOT go under frame when rotor is turning or engine is running. Keep others away.
- Disconnect & lockout power source BEFORE adjusting or servicing.
- Keep hands, feet, hair, and clothing away from moving parts.

⚠ DANGER

GUARD MISSING WHEN THIS IS VISIBLE DO NOT OPERATE ENTANGLEMENT HAZARD

⚠ WARNING

ENGAGE TRACTOR CLUTCH SLOWLY DURING START UP OR DAMAGE WILL OCCUR. KEEP PTO SHAFT WITH 25° OF LEVEL DURING OPERATION.

⚠ DANGER ⚠

High Pressure Fluid Hazard.

High pressure fluid leak will pierce skin. Release pressure before working on system.

Detect leaks with wood or cardboard. Wear sturdy gloves and goggles. NEVER use fingers.

Fluid injected in skin must be surgically removed by trained doctor immediately or gangrene will result.

Fluid injected into skin will injure or kill.

⚠ WARNING

Read and understand operators manual before using this machine.

⚠ WARNING! DO NOT MOW IN REVERSE OR DAMAGE WILL OCCUR TO YOUR MOWER!

⚠ DANGER! STAY BACK 150 FEET AT ALL TIMES

INTRODUCTION

MECHMAXX welcomes you to the growing family of new product owners. This implement has been designed with care and built by skilled workers using quality materials. Proper assembly, maintenance, and safe operating practices will help you get years of satisfactory use from the machine.

The Flail Mowers are designed for Category 2 three-point hitch or Quick-Hitch System mounting. These Fixed Bar Flail Mowers are ideal for ripping, leveling, finish grading, and backfilling applications at feedlots, outdoor arenas, building sites, and maintenance operations on farm and ranch lanes or roadways.

USING THIS MANUAL

1. This Operator's Manual is designed to help familiarize you with safety, assembly, operation, adjustments, troubleshooting, and maintenance. Read this manual and follow the recommendations to help ensure safe and efficient operation.
2. The information contained within this manual was current at the time of printing. Some parts may change slightly to assure you of the best performance.
3. To order a new Operator's or Parts Manual contact your authorized dealer. Manuals can also be printed from the MECHMAXX Service & Support Center by your dealer.

TERMINOLOGY

"Right" or "Left" as used in this manual is determined by facing the direction the machine will operate while in use unless otherwise stated.

Note: A special point of information that the operator must be aware of before continuing.

Important: A special point of information related to its preceding topic. The intention is that this information should be read and noted before continuing.

OWNER ASSISTANCE

The Warranty Registration card should be filled out by the dealer at the time of purchase. This information is necessary to provide you with quality customer service. If customer service or repair parts are required contact a dealer. A dealer has trained personnel, repair parts and equipment needed to service the machine.

The parts on your machine have been specially designed and should only be replaced with genuine parts.

Serial Number Plate

For prompt service always use the serial number and model number when ordering parts from your dealer. Be sure to include your serial and model numbers in correspondence also.

ASSEMBLY AND SET-UP

TRACTOR REQUIREMENTS

This mower is designed with a 3-Point category 2 hitch. Tractor horsepower rating should be between 80–110 (VBM86: 90-120) horsepower.

PACKING DESCRIPTION

1. Remove and check

Remove the packing, check goods without defect and omission.

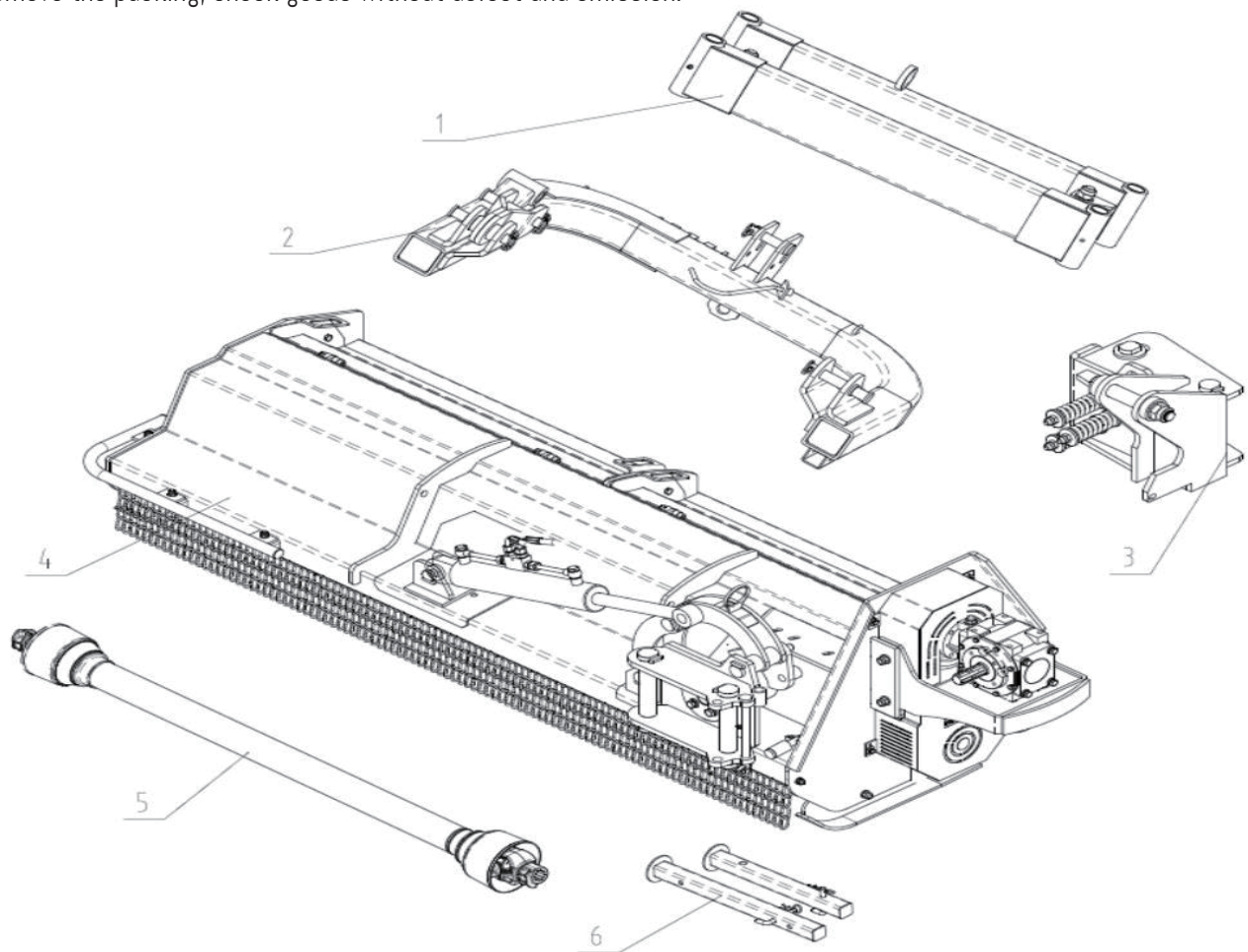

Figure 1-1: The Mower and Accessory in Package

2. Packing List

The detailed packing list of the mower and accessory as the following table.

Item	Description	Qty.	Package Form
1	Swing arms sub-assembly and fittings	1	Bubble film
2	Hitch tube weldment and fittings	1	Bubble film
3	Translation Plate Welding Component	1	Bubble film
4	Main body of the mower and fittings	1	None
5	PTO shaft	1	None
6	Support Leg assembly and fittings	2	Bubble film

The detailed description of main body of the mower and fittings

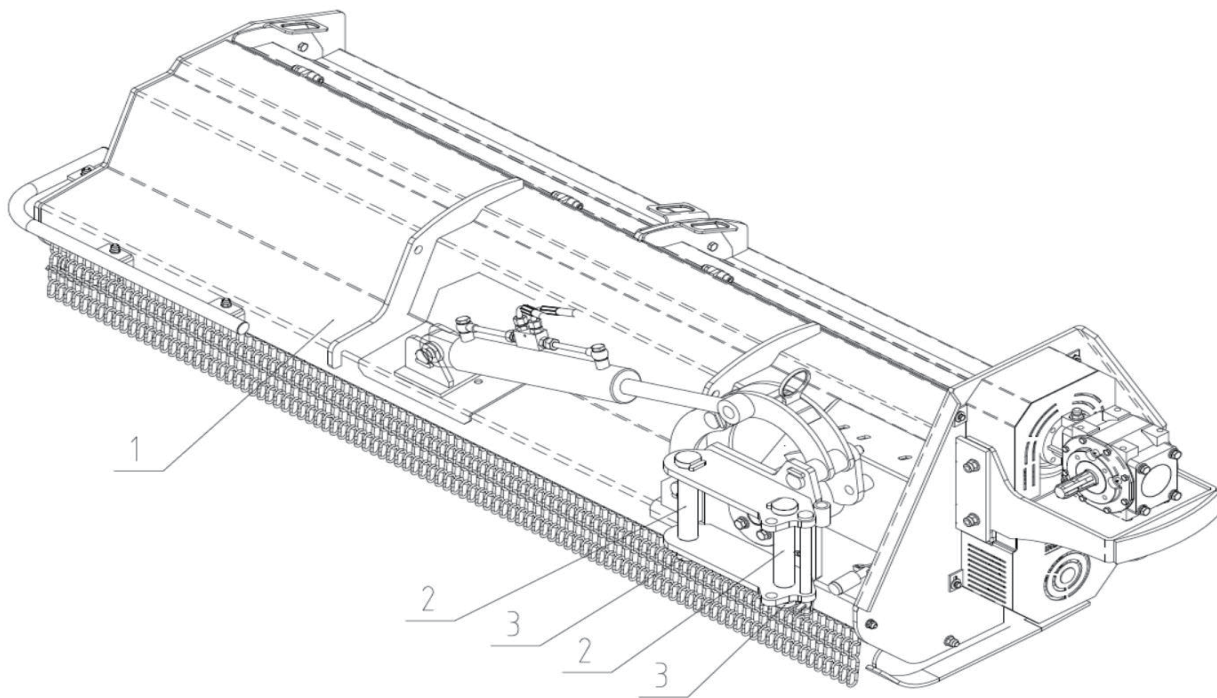

Figure 1-2: Main Body of The Mower and Fittings

Item	Description	Qty.
1	Main body of the mower	1
2	Swing arm pin-longer	2
3	Locknut M30x2	2

The detailed description of swing arms sub-assembly and fittings

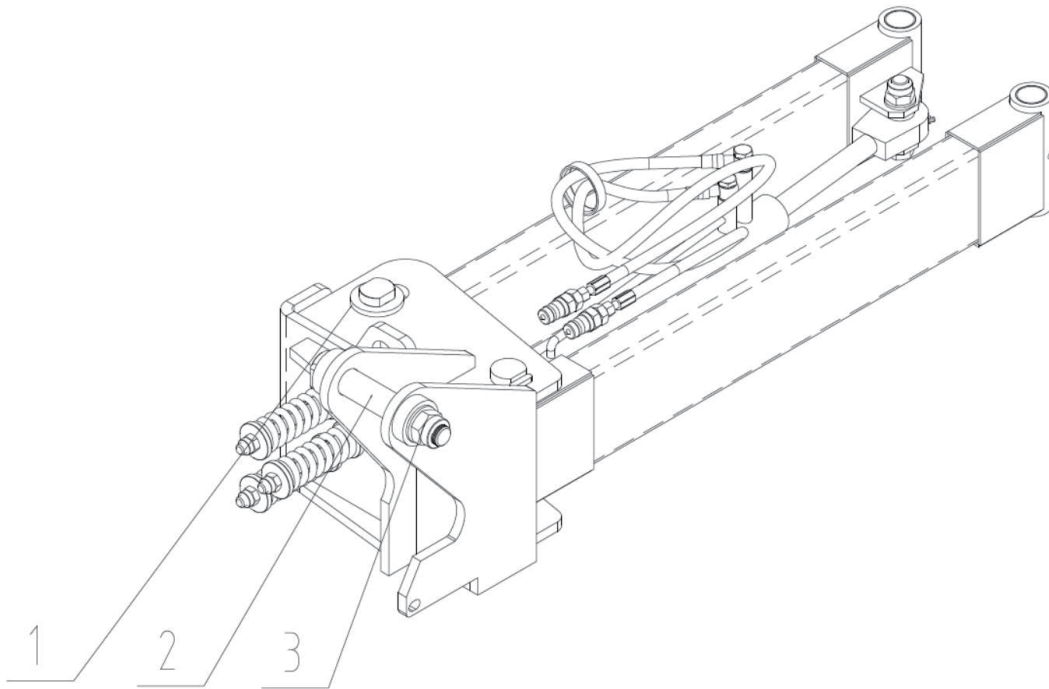

Figure 1-3: Swing Arms Sub-Assembly and Fittings

Item	Description	Qty.
1	Swing arms sub-assembly	1
2	Swing arm pin-Shorter	1
3	Locknut M30x2	1

The detailed description of hitch tube weldment and fittings

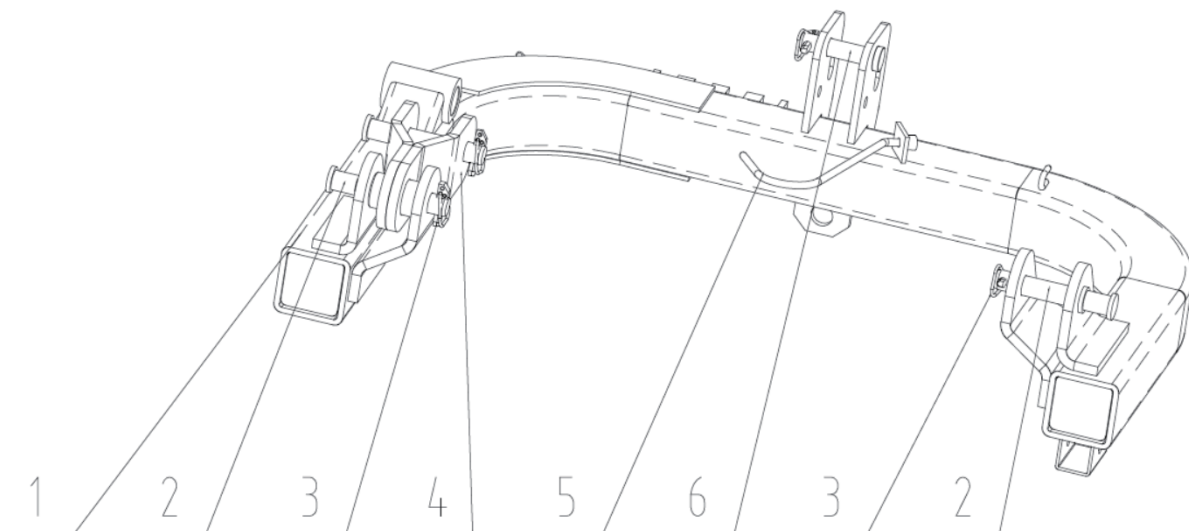

Figure 1-4: Hitch Tube Weldment and Fittings

Item	Description	Qty.
1	Hitch tube weldment	1
2	Hitch pin - Lower	3
3	Safety lock pin	4
4	Small hanging weldment	1
5	PTO shaft hook	1
6	Hitch pin - Upper	1

The detailed description of Support Leg Assembly

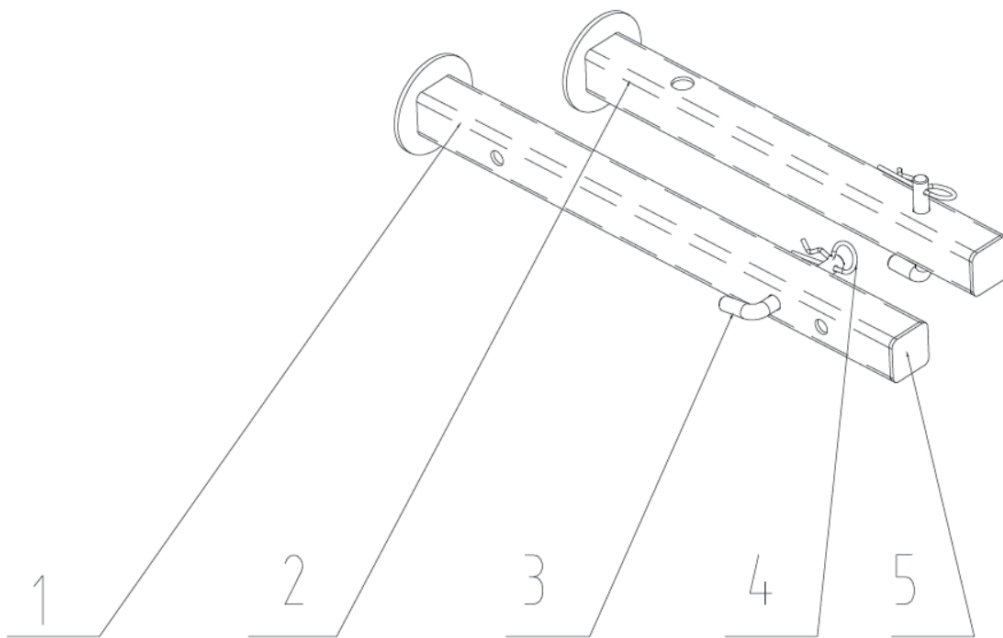

Figure 1-5: Support Leg Assembly

Item	Description	Qty.
1	Long Support Leg Welded Parts	1
2	Short Support Leg Welded Parts	1
3	Support Leg Pin	2
4	R Pin 3.2	2
5	40 Leg Cover	2

INSTALLATION WIZARD

The installation wizard will guide you to finish the final assembly of your new mower easily.

1. Tool Required

Air impact wrench with 46mm sleeve

T type socket wrench 13mm

T type socket wrench 18mm

2. Torque Application

Refer to bolt torque in Section 7 Appendix.

3. Assembly

Step1: Installing Swing Arms Sub-Assembly

Remove the packaging of swing arms sub-assembly and fittings.

Push swing arms sub-assembly into the overturning bracket weldment as shown in figure1-6. Fix it with 2pcs of swing arm pins-longer, 2pcs of locknuts M30x2.

Tighten locknuts completely.

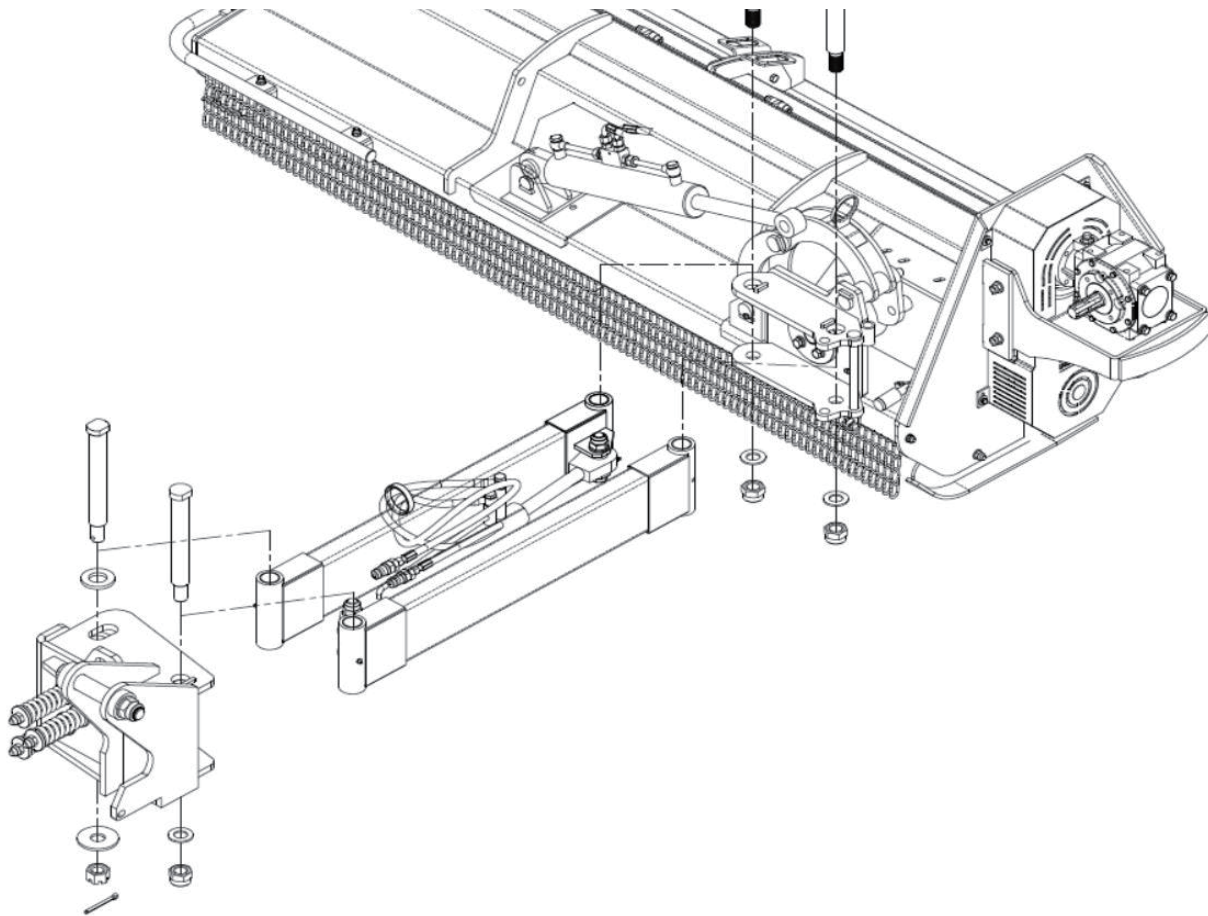

Figure 1-6: Installing Swing Arms Sub-Assembly

Step2: Installing Hitch Tube Weldment and Fittings

Remove the packaging of hitch tube weldment and fittings.

Fix hitch tube weldment to swing arms sub-assembly with 1pcs of swing arm pin-shorter, 1pcs of locknut M30x2.

Tighten locknuts completely.

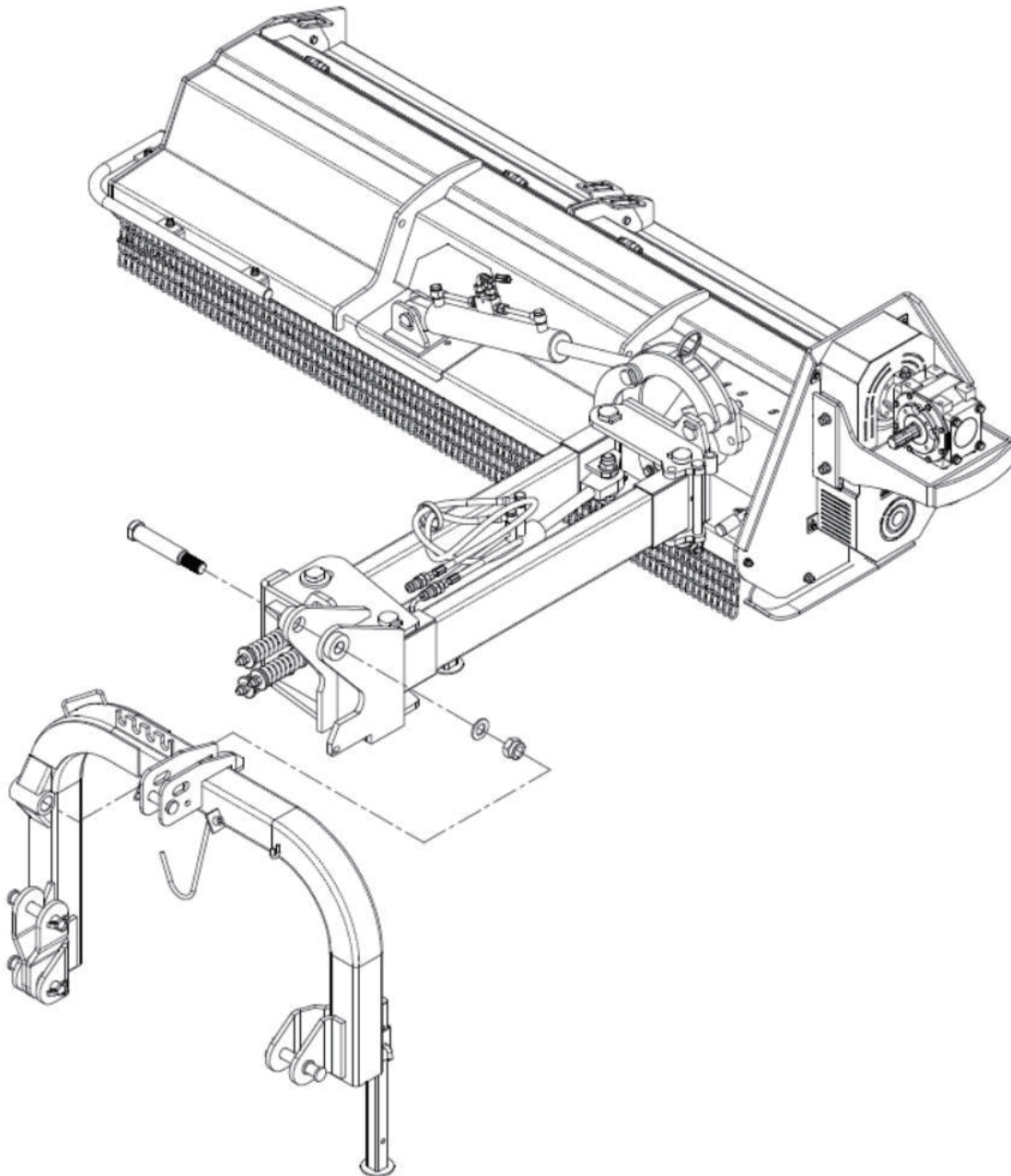

Figure 1-7: Installing Hitch Tube Weldment and Fittings

Step3: Installing Rake Sub-Assembly

Remove the packaging of Rake Sub-Assembly.

Insert raker weldment-longer into the tube on swing arm weldment-L as well as raker pin and insert R pin into the hole on raker pin. Insert raker weldment-shorter into the tube on hitch tube weldment as well as raker pin and insert R pin into the hole on raker pin. Pass all oil pipes through the guide ring and fix them with oil pipe clamps.

Note: The length of oil pipes between oil cylinders and pipe clamps shall be reserved with allowance to prevent oil pipes from being damaged during swing arms moving left and right and main body of the mower turning up and down.

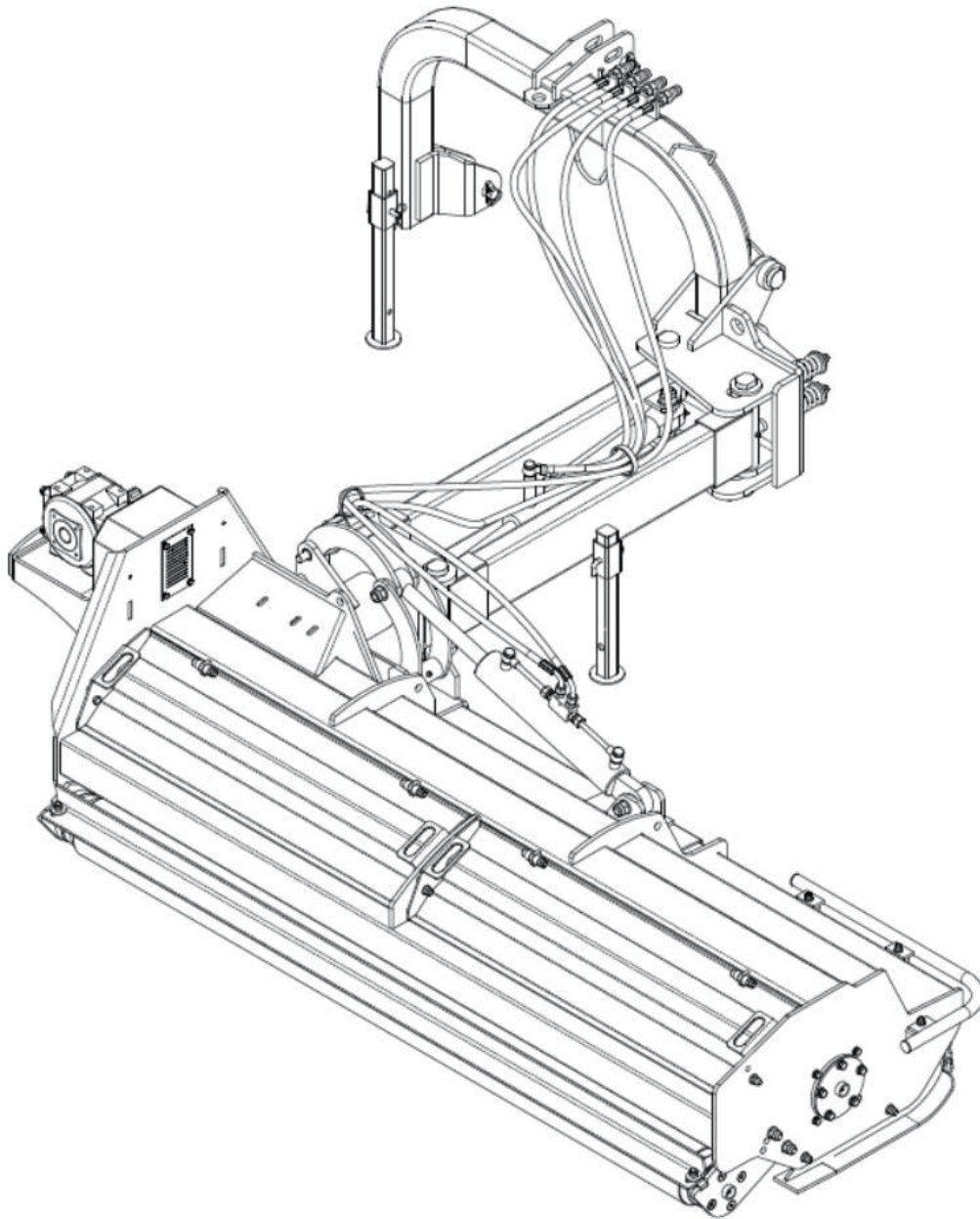

Figure 1-8: Installing Rake Sub-Assembly and Oil Pipes Fixation



Fill the gearbox with proper amount of gear oil before operation. Ensure that the height of the rotation axis from the ground is greater than 700mm, otherwise one side of the mower will touch the ground in advance, resulting in damage to the connecting plate and hinging bracket. Refer to figure 1-6.

TRACTOR HOOK-UP

1. Be certain that tractor draw bar will not interfere. Move draw bar ahead or remove if required. Draw bar should also be checked for clearance when unit is being raised for the first time.
2. Align lower link arms of tractor to hitch clevises on mower. Insert lower hitch pins into lower ball swivels and attach link pins.
3. Attach tractor top link to upper floating hitch on mower with pin supplied. Secure with lock pin.
4. Adjust tractor top link in or out to place upper hitch pin vertically above or slightly behind lower hitch pins to allow mower flotation.

The mower should be run with the back 15 degrees lower than the front.

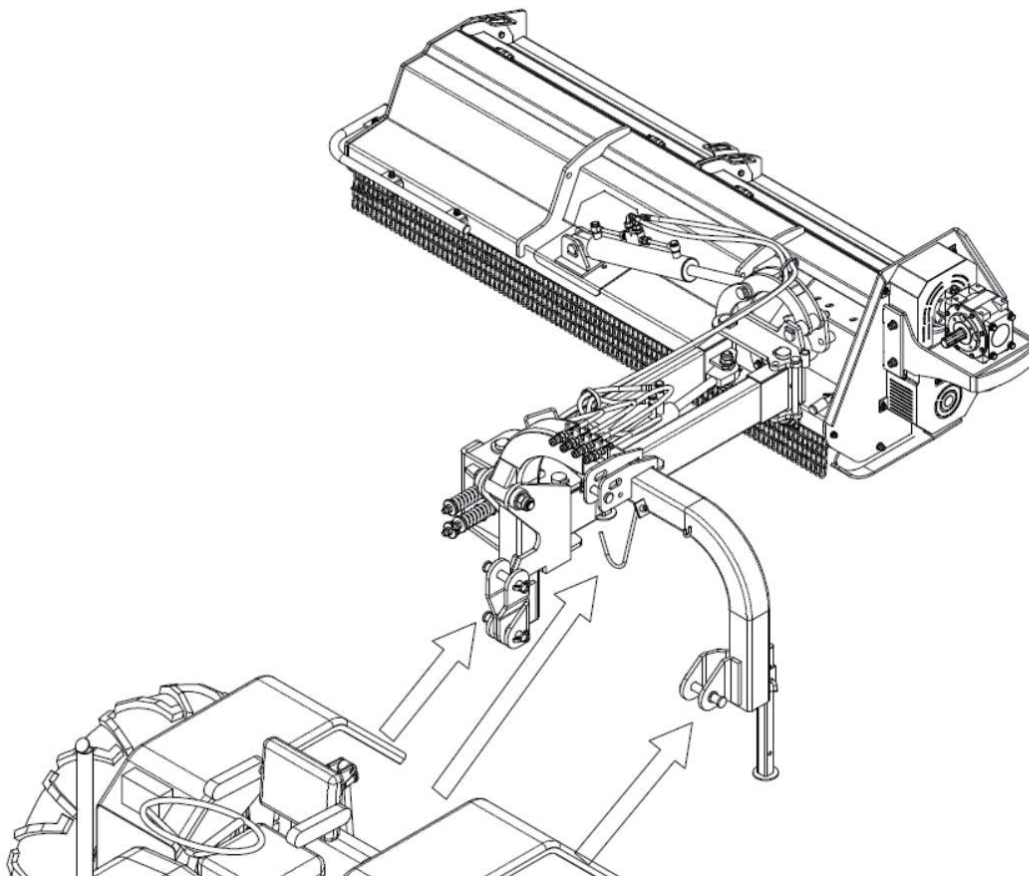

Figure 1-9: Tractor Hook-up

DRIVELINE INSTALLATION

1. Slide driveline end with extended safety cone over spline shaft of gearbox and secure with attaching device.
2. Slide driveline over tractor's spline PTO shaft and secure with locking device of driveline.
3. Driveline should now be moved back and forth to ensure that it is secure on the PTO shaft of the tractor and mower gearbox.
4. Attach chain from the driveline shield to one of the upper hitch braces to ensure that the shield does not rotate.
5. Should driveline require shortening:
 - a. Hold the half-shafts next to each other in the shortest working position and mark them.
 - b. Shorten inner and outer guard tubes equally.
 - c. Shorten inner and outer sliding profiles by the same length as the guard tubes.
 - d. Proper overlap is a minimum of one-half the length of each tube, with both tubes being of equal length.
 - e. Round off all sharp edges and remove burrs. Grease sliding profiles.



Tractor PTO shield and all mower guards must be always in place during operation!

OPERATING INSTRUCTIONS

MUST ADD OIL BEFORE FIRST USE.

THE GEARBOX AND TRANSMISSION ARE SHIPPED WITHOUT OIL.

ADD OIL BEFORE FIRST USE!

Gear Oil SAE90 700ml

TRANSPORTING

NOTE: Always disengage PTO before raising mower to transport position.

1. When raising the mower to transport position, be sure that driveline does not contact tractor or mower. Adjust and set the tractor's 3- point hitch lift height so that the driveline does not contact mower deck in the fully raised position.
2. Be sure to reduce tractor ground speed when turning, leaving enough clearance so that the mower does not contact obstacles such as buildings, trees or fences.
3. Select a safe ground travel speed when transporting from one area to another. When traveling on roadways, transport in such a way that faster moving vehicles may pass safely.
4. When traveling over rough or hilly terrain, shift tractor to a lower gear.



CAUTION

When traveling on public roads, whether at night or during the day, use accessory lights and devices for adequate warning to operators of other vehicles. Comply with all Federal, State, and local laws.

MOWING INSTRUCTIONS

1. Clear area to be mowed of objects and debris that might be picked up and thrown by the mower blades.
2. Grass is best cut when it is dry. Mowing wet grass can cause plugging resulting in grass clumps behind the mower.
3. Grass should be mowed frequently as shorter clippings deteriorate faster.
4. If mowing extremely tall grass, it is best to raise cutting height and mow the area, then lower cutting height and mow a second time at the desired height.

OPERATING INSTRUCTIONS

Proper servicing and adjustments are the key to the long life of any machine. With careful and systematic inspection of the mower, costly maintenance, time and repair can be avoided.

Before beginning to mow, the following inspection should be performed:

1. Check oil level in gearbox.
2. Check that all plugs in gearbox have been replaced and tightened properly.
3. Be sure all mower knives, bolts and nuts are tight.
4. Be certain all guards and shields are in place and secure.
5. Grease driveline shaft and all other grease fittings.
6. Clear area to be mowed of rocks, branches and other foreign objects.
7. Lower mower to ground. Set tractor throttle at approximately 1/4 open. Engage PTO to start blades rotating.
8. Operate with 540 rpm PTO tractor.
9. At first begin mowing at a slow forward speed and shift up until the desired speed is achieved - maintaining 540 PTO rpm.
10. Mower knives will cut better at a faster blade speed than at reduced throttle.
11. After mowing the first 50 feet, stop and check to see that the mower is adjusted properly.
12. Do not make sharp turns or attempt to back up while mower is on the ground.
13. Do not engage PTO with mower in the fully raised position. Do not engage PTO at full throttle.

ADJUSTMENTS

LEVELING THE MOWER

NOTE: Tractor and mower should be on level ground.

Leveling can be adjusted at the tractor's 3-point arms and center link.

CUTTING HEIGHT ADJUSTMENT

The machines cutting height depends upon the position of the rear roller.

1. Remove the bolts that fix the roller on both sides.
2. Lift or lower both sides of roller in equal measurements.
3. Replace bolts and re-tighten.

3-POINT HITCH ADJUSTMENTS

The 3-point hitch system on this mower has been designed for front to back flotation when mowing on uneven terrain. Adjust tractor's top center link to place the upper hitch pin vertically above or slightly behind the lower hitch pins. The mower should be run with the back 15 degrees lower than the front.

The hitch can also be adjusted from side to side by turning the adjustment handle. Turn handle until you have achieved your desired location.



Engage parking brake, shut off tractor, remove key and disengage PTO before making any height adjustments!



Excessive tension on the belt may lead to premature failure of belt and drive components. Excessive tension on the belt may also lead to a safety hazard to the operator or bystanders.

BELT TENSION



Belt drive system under spring tension; use care to avoid bodily harm!

The Belt tension should be checked after the first 20 hours of use. And then every 40 hours of use.

1. Tension on the belt can be adjusted with the belt tension bolt. Turn the bolt until desired tension is achieved. When the belt has the correct tension the gearbox should be adjusted so that the gearbox extension is running straight (parallel) with the flail mower. Loosen bolts at the bottom of the gearbox and move gearbox until gearbox extension is running straight.
2. Excessive tension on the belt may lead to premature failure of belt and drive components.

MAINTENANCE AND LUBRICATION

MAINTENANCE

Proper servicing and adjustment is the key to the long life of any farm implement. With careful and systematic inspection, you can avoid costly maintenance, time and repair.



For safety reasons, each maintenance operation must be performed with tractor PTO disengaged, mower lowered completely to ground and tractor engine shut off with ignition key removed.

- 1. After using the mower for several hours, check all bolts to be sure they are tight and check drive belt tension.**
- 2. Replace any worn, damaged or illegible safety decals by obtaining new decals from dealer.**

KNIFE REPLACEMENT

IMPORTANT Make sure that the knife is the same length as the others on the mower. This will keep the rotor rotation balanced.

1. Remove bolt and nut.
2. Remove old knife.
3. Install new knife and existing bolt.
4. Secure with nut.

V-BELT INSTALLATION



Belt drive system under spring tension; use care to avoid bodily harm!

- 1. Remove belt guard fender and belt cover.**
- 2. Disengage belt tension by loosening belt tension bolt until belt can be removed.**
- 3. With tension relieved from belt remove old belt from pulleys.**
- 4. Tighten belt tension bolt.**
- 5. Reinstall belt guard and belt guard fender.**

STORAGE

At the end of the working season or when the mower will not be used for a long period, it is good practice to clean off any dirt or grease that may have accumulated on the mower and any of moving parts.

1. Clean as necessary.
2. Check knives for wear and replace if necessary.
3. Inspect mower for loose, damaged or worn parts and adjust or replace as needed.
4. Store unit inside if possible for longer life.
5. Repaint parts where paint is worn or scratched to prevent rust.
6. Replace all damaged or missing decals.

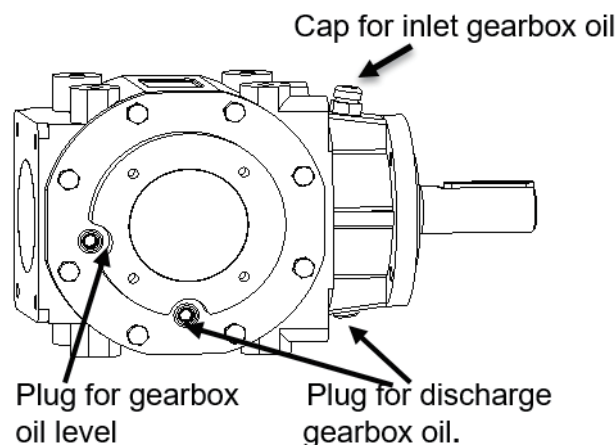

LUBRICATION

Driveline Shaft U-Joints

Type of Lubrication: Multi-purpose Grease



Roller Bearing (Both Ends)

Type of Lubrication: Multi-purpose Grease



Cutter Rotor Bearing (Both Ends)

Type of Lubrication: Multi-purpose Grease



Check Gearbox oil

Type of Lubrication: SAE 90W Gear Lube

Check oil level in gearbox by removing the plug located on the right-hand side. Oil should be level with bottom of plug hole. Add oil if necessary, by removing top fill plug and side plug. Add oil until it flows from side plug hole.

Do not overfill!

IMPORTANT: Mower should be level when checking oil in gearbox!

SPECIFICATIONS & CAPACITIES

Model	VBM78	VBM86
Power Required	80-110 Hp	90-120 Hp
Working Width	78 in	86 in
Overall Width	94 in	101 in
Blade Ground Clearance	0.5 in-2.6 in	
Max. Cutting Diameter	6 in	
Offset Distance from The Center (Maximum)	122 in	130 in
Tilt-Up Angle	90°	90°
Tilt-Down Angle	55°	55°
Number Of Blades	18	20
Number of Belts	4	
Blade Type	Hammer	
Blade Weight	2.6 lbs	
Blade Material	Cast Steel	
Belt Adjustment	Bolt Tightening	
Working Efficiency	450 cu.ft./Hr.	
Rotor Diameter	5.5 in	
Rotor Thickness	0.5 in	
Rear Roller Diameter	6 in	
Rear Roller Thickness	0.25 in	
PTO Shaft Speed	540 rpm	
Deck Thickness	2 in	
Side Plate Thickness	0.25 in	
Driveline Shaft Length	T6-LF-73 With Shear Bolt; 73in-126in	
Spline End	1.375in Z6	
3-Point Hitch	CAT 2	
Gearbox Oil Type	85W-90	
Finish	Powder Coating	
Warranty	1 Year	
Shipping Box	100x41x31 in	109 X 41 X 31in
Weight (N.W./G.W.)	1848/2040 lbs	1848/2040 lbs

TROUBLESHOOTING

Problem	Solution
Do not try to clean rear discharge area when mower is running. Bodily harm may occur!	
Belt slipping	Unplug and clean mower deck.
	Remove belt guard shields and clean sheaves.
	Replace belt.
	Mow at full throttle (540 PTO rpm), check PTO speed and tractor engine.
Patches of uncut grass	Shift transmission to a lower gear.
	Tighten belts.
	Replace missing knives.
Excessive vibration	Replace knives.
	Replace drive belt.
	Replace pulleys or align.
Gearbox noisy	Remove belt guard shields & clean debris from belt area & sheaves.
	Check lubricant level.
Knives scalping grass	Raise cutting height by adjusting roller.
	Change mowing pattern.
	Reduce speed turns.
Uneven cut	Shift to a lower gear.
	Level mower.
	Replace missing knives.
Tractor loaded down by mower	Mow at full throttle (540 PTO rpm).
	Shift to a lower gear.
	Clean mower.

APPENDIX

WARRANTY

MECHMAXX warrants to the original purchaser that this product will be free from defects in material and workmanship beginning on the date of purchase by the end user according to the following schedule when used as intended and under normal service and conditions for personal use.

Overall Unit and Driveline: One-year.

Blades and Belts: Considered wear items.

This warranty is limited to the replacement of any defective part by manufacturer and the installation by the dealer of any such replacement part, and does not cover common wear items such as blades, belts, tines, etc. MECHMAXX reserves the right to inspect any equipment or parts which are claimed to have been defective in material or workmanship.

This warranty does not apply to any part or product which in MECHMAXX's judgment shall have been misused or damaged by accident or lack of normal maintenance or care, or which has been repaired or altered in a way which adversely affects its performance or reliability, or which has been used for a purpose for which the product not designed. Misuse also specifically includes failure to properly maintain oil levels, grease points, and driveline shafts.

Claims under this warranty must be made to the dealer which originally sold the product and all warranty adjustments must be made through such dealer. MECHMAXX reserves the right to make changes in materials or design of the product at any time without notice.

This warranty shall not be interpreted to render MECHMAXX liable for damages of any kind, direct, consequential, or contingent to property. Furthermore, MECHMAXX shall not be liable for damages resulting from any cause beyond its reasonable control. This warranty does not extend to loss of crops, any expense or loss for labor, supplies, rental machinery or for any other reason.

BOLT TORQUE

The tables shown below give correct torque values for various bolts and cap screws. Tighten all bolts to the torques specified unless otherwise noted. Check tightness of bolts periodically, using bolt torque chart as a guide. Replace hardware with the same strength bolt.

ENGLISH TORQUE SPECIFICATIONS

Bolt Diameter	Bolt Torque					
	SAE 2		SAE 5		SAE 8	
	N.m	lb-ft	N.m	lb-ft	N.m	lb-ft
1/4"	8	6	12	9	17	12
5/16"	13	10	25	19	36	27
3/8"	27	20	45	33	63	45
7/16"	41	30	72	53	100	75
1/2"	61	45	110	80	155	115
9/16"	95	60	155	115	200	165
5/8"	128	95	215	160	305	220
3/4"	225	165	390	290	540	400
7/8"	230	170	570	420	880	650

METRIC TORQUE SPECIFICATIONS

Bolt Diameter	Bolt Torque			
	8.8		10.9	
	N.m	lb-ft	N.m	lb-ft
M3	0.5	0.4	1.8	1.3
M4	3	2.2	4.5	3.3
M5	6	4	9	7
M6	10	7	15	11
M8	25	18	35	26
M10	50	37	70	52
M12	90	66	125	92
M14	140	103	200	148
M16	225	166	310	229
M20	435	321	610	450
M24	750	553	1050	744
M30	1495	1103	2100	1550
M36	2600	1917	3675	2710

PART BREAKDOWN LIST

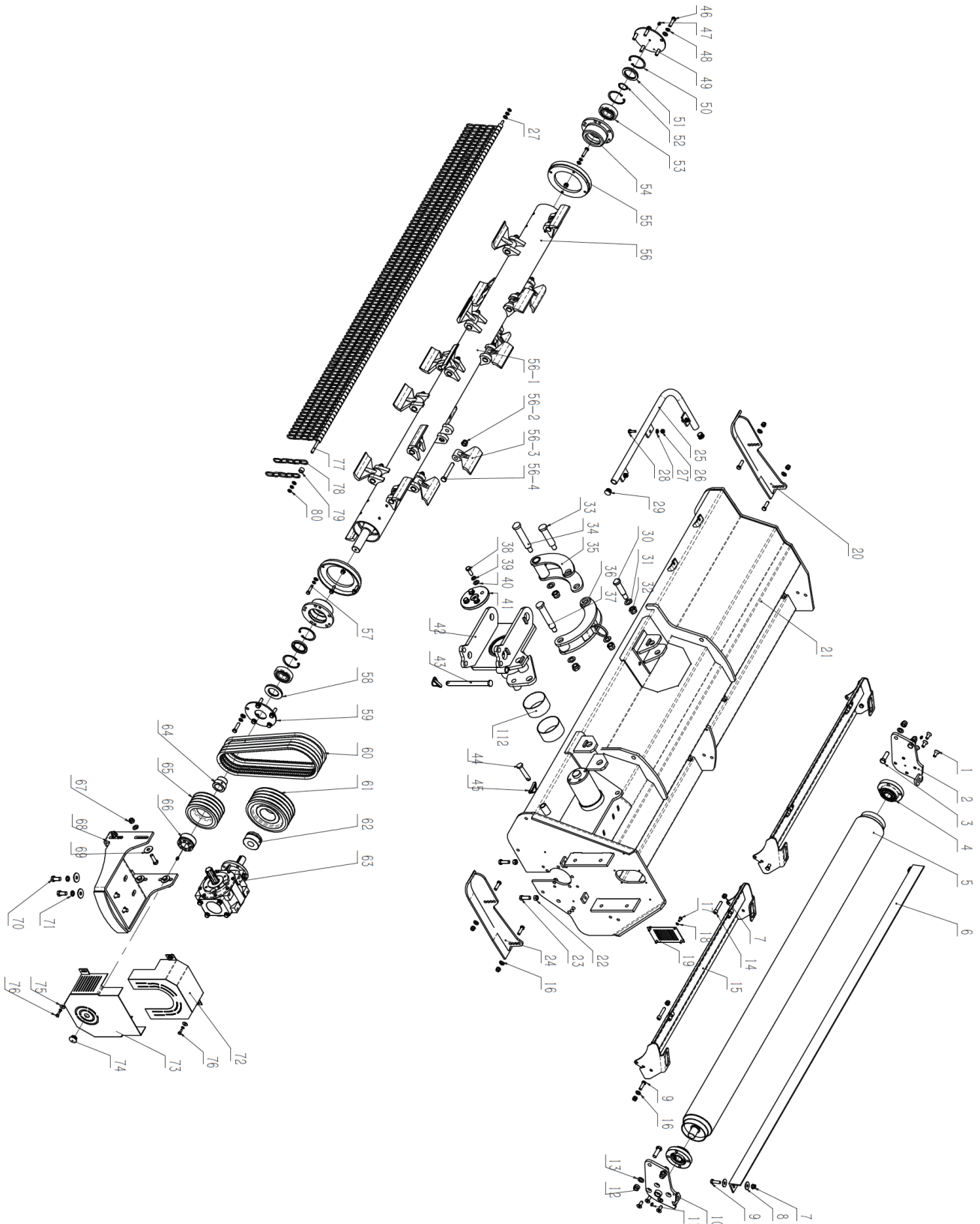

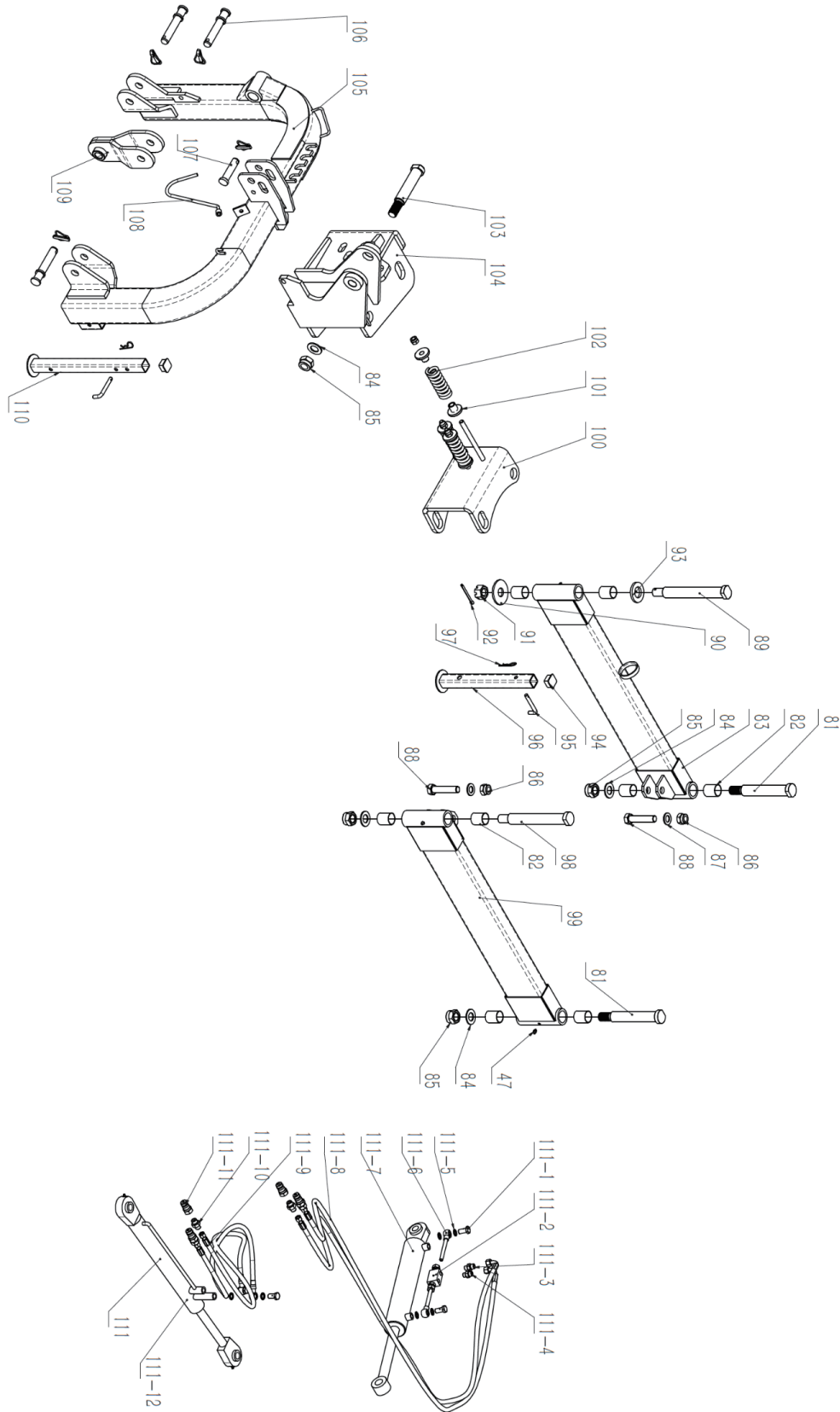

PARTS LIST

No.	DESCRIPTION	QTY
1	Bolt M12*30	9
2	Roller Mounting Plate -Right	1
3	Bolt M16 * 50	4
4	Reverse Installation Of Bearing Ucu207	2
5	Roller Welded Parts	1
6	Clean Shoe	1
7	Nut M12	13
8	Large Washer 12	4
9	Bolt M12 * 40	9
10	Roller Mounting Plate-Left	1
11	Straight Through Pressure Oil Cup M8 *1	3
12	Nut M16	7
13	Flat Washer 16	4
14	Internal Hexagonal Bolt M12 *60	4
15	Rear Cover Welding Parts	2
16	Flat Washer 12	21
17	Bolt M8 * 16	4
18	Washer 8	8
19	Sealing Plate 01	1
20	Base Weldment 02	1
21	Hood Welding Parts	1
22	Nut M14	2
23	Bolt M14 *45	6
24	Base Weldment 01	1
25	Collision Bar Welded Parts	1
26	Nut M10	3
27	Flat Washer 10	13
28	Bolt M10*30	3
29	24 Cover	2
30	Pin Shaft 06	1

No.	DESCRIPTION	QTY
31	Washer 20	4
32	Nut M20	4
33	Pin Shaft 04	1
34	Pin Shaft 05	1
35	Lower Moon Plate Weldment	1
36	Upper Moon Plate Weldment	1
37	Pin Shaft 03	1
38	Bolt M14*35	4
39	Elastic Washer 14	4
40	Flat Washer 14	8
41	End Cap	1
42	Yoke Shaft Welding Component	1
43	Positioning Pin 01	1
44	Positioning Pin 02	1
45	Lock Pin Welded Parts	6
46	Bolt M12 * 45	10
47	Grease M10	8
48	Washers 12	14
49	Blind Cover Weldment	1
50	Elastic Retaining Ring 80	4
51	Oil Seal 55x80x8	2
52	Retaining Ring 40	1
53	Bearing 1308	2
54	External Bearing Seat	2
55	Blade Axle Protective Sleeve	2
56	Blade Axle Assembly	1
56-1	Blade Axle Weldment	1
56-2	Nut M16* 1.5-10	18/20
56-3	Hammer (1200g)	18/20
56-4	Bolt M16*1.5*100-10.9	18/20

No.	DESCRIPTION	QTY
57	Bolt M10*45	8
58	Oil Seal 50x90x8	1
59	Transparent Cover 02	1
60	Toothed V-Belt Av17x1321	4
61	Large Pulley	1
62	Expansion Sleeve Reach 04 Type 33x80	1
63	Gearbox T102	1
64	Oil Seal Sleeve	1
65	Small Pulley	1
66	Sleeve Reach 04 40x80	1
67	Nut M14	4
68	Gearbox Seat	1
69	Large Washer 14	8
70	Bolt M16*35	4
71	Washer 16	4
72	Up Belt Cover	1
73	Lower Belt Cover	1
74	25 Cover	1
75	Enlarged Flat Cushion 8	4
76	Bolt M8* 20	4
77	Hanging Rod	1
78	Chain	109
79	Chain Spacer Sleeve	110
80	Nut M10	4
81	Long Selling	2
82	Bushing 44 *40 *50	8
83	Rear Swing Arm Weldment	1
84	Flat Washer 30	4
85	Nut M30 * 2	4
86	Nut M24	2
87	Flat Pad 24	2

No.	DESCRIPTION	QTY
88	Bolt M24*110	2
89	Pin Shaft 01	1
90	Washers 30	1
91	Nut M30*2	1
92	Split Pin 8 * 80	1
93	Pin Shaft 01 Gasket	1
94	40 Leg Cover	2
95	Support Leg Pin	2
96	Short Support Leg Welded Parts	1
97	R Pin 3.2	2
98	Pin Shaft 02	1
99	Front Swing Arm Welded Parts	1
100	Translation Plate Welding Component	1
101	Spring Washer	6
102	Avoid Compression Springs	3
103	Short Selling	1
104	Horizontal Bracket Welding Component	1
105	Suspension Bracket Welded Parts	1
106	Lower Suspension Pin	3
107	Upper Suspension Pin	1
108	A Hook	1
109	Small Hanging Bracket Welded Parts	1
110	Welding Parts For Long Support Legs	1
111	Hydraulic System Assembly	1
111-1	Hinged Bolt M16*1.5*45	4
111-2	Bidirectional Hydraulic Lock Vrpc-G3/8-121	1
111-3	End Straight Joint G3/8-M18*1.5	1
111-4	End Straight Joint G3/8-M18*1.5 (With Orifice)	1
111-5	Combination Washer 16	8
111-6	Ball Joint Assembly	2
111-7	Flip Cylinder 250	1

No.	DESCRIPTION	QTY
111-8	Flip Cylinder Hydraulic Hose M18*1.5 Length:3750mm	2
111-9	Swing Cylinder Hydraulic Hose M18*1.5 Length:3000mm	2
111-10	End Straight Joint Npt1/2-M18*1.5	4
111-11	Quick Change Male Connector Npt1/2	4
111-12	Swing Cylinder	1
112	Bushing Sf-2-115 *110*60	2

MechMaxx

info@mechmaxx.com