

# OPERATOR'S SAFETY AND SERVICE MANUAL



# SCREEDEMON

This manual covers the following serial numbers and higher for each model listed:

WS500. . . . . 1430000



# WET SCREED

**MBW, Inc.**  
250 Hartford Rd • PO Box 440  
Slinger, WI 53086-0440  
Phone: (262) 644-5234  
Fax: (262) 644-5169  
Email: [mbw@mbw.com](mailto:mbw@mbw.com)  
Website: [www.mbw.com](http://www.mbw.com)

**MBW Europe Ltd.**  
Units 2 & 3 Cochrane Street  
Bolton BL3 6BN  
England, UK  
Phone: +44 (0) 01204 387784  
Fax: +44 (0) 01204 387797  
Email: [saleseurope@mbw.com](mailto:saleseurope@mbw.com)  
Website: [mbw-europe.com](http://mbw-europe.com)

L23182 / 3.25.B  
©MBW, Inc. 2024  
Printed in the USA

# TABLE OF CONTENTS

---

<b>SAFETY INFORMATION</b> .....	<b>1</b>	Engine Maintenance.....	7
Introduction .....	1	Engine Speed.....	7
Safety Precautions .....	1	Cleaning .....	7
<b>SPECIFICATIONS</b> .....	<b>3</b>	<b>SERVICE</b> .....	<b>8</b>
<b>OPERATION</b> .....	<b>4</b>	Torque Chart .....	8
Introduction .....	4	Engine Mounting Flange Removal .....	8
Before Starting & Operating .....	4	Handle Removal.....	8
Attaching Blade.....	4	Exciter Disassembly.....	8
Starting Engine .....	4	Exciter Assembly .....	9
Stopping Engine .....	4	Engine Mounting Flange & Engine Assembly .....	9
Operation .....	5	Parts Replacement Cycles and Tolerances .....	9
Handle Adjustment .....	6	<b>REPLACEMENT PARTS</b> .....	<b>11</b>
Kickstand .....	6	Main Assembly .....	12
Transporting .....	6	Exciter Assembly .....	14
<b>MAINTENANCE</b> .....	<b>7</b>	Engine and Engine Mount .....	16
Maintenance Schedule .....	7	<b>WARRANTY</b> .....	<b>18</b>



# **WARNING**



---

## **CALIFORNIA PROPOSITION 65 WARNING**

Engine exhaust and some of its constituents and dust produced during the use of this product contain chemicals known in the state of California to cause cancer, birth defects, and other reproductive harm.

For more information go to **[www.P65Warnings.ca.gov](http://www.P65Warnings.ca.gov)**

# SAFETY INFORMATION

## Introduction



This Safety Alert Symbol is used to call attention to items or operations which may be dangerous to those operating or working with this equipment.

The symbol can be found throughout this manual and on the unit. Please read these warnings and cautions, along with all decals, carefully before attempting to operate the unit. Make sure every individual who operates or works with this equipment is familiar with all safety precautions.

### **WARNING**

**GENERAL WARNING.** Indicates information important to the proper operation of the equipment. Failure to observe may result in damage to the equipment and/or severe bodily injury or death.

### **CAUTION**

**GENERAL CAUTION.** Indicates information important to the proper operation of the equipment. Failure to observe may result in damage to the equipment.

## Safety Precautions



**LETHAL EXHAUST GAS:** An internal combustion engine discharges carbon monoxide, a poisonous, odorless, invisible gas. Death or serious illness may result if inhaled. Operate only in a properly ventilated area. **NEVER OPERATE IN A CONFINED AREA!**



**DANGEROUS FUELS:** Use extreme caution when storing, handling and using fuels as they are highly volatile and explosive in vapor state. Do not add fuel while engine is running. Stop and cool the engine before adding fuel. **DO NOT SMOKE!**



**SAFETY GUARDS:** It is the owner's responsibility to ensure that all guards and shields are in place and in working order.



**IGNITION SYSTEMS:** Breakerless, magneto, and battery ignition systems can cause severe electrical shocks. Avoid contacting these units or their wiring.



**SAFE DRESS:** Do not wear loose clothing, rings, wristwatches, etc. near machinery.



**NOISE PROTECTION:** Wear OSHA specified hearing protection devices.



**EYE PROTECTION:** Wear OSHA specified eye shields, safety glasses, and sweat bands.



**FOOT PROTECTION:** Wear OSHA specified steel-tipped safety shoes.



**HEAD PROTECTION:** Wear OSHA specified safety helmets.

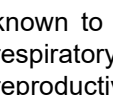

**OPERATOR:** Keep children and bystanders off and away from the equipment.

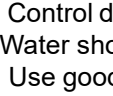

**DUST PROTECTION:** Machining, crushing or handling of stone, concrete, masonry, metal and other materials may generate dust, mist and fumes containing chemicals such as silica

known to cause serious or fatal injury or illness such as respiratory disease, silicosis, cancer, birth defects, or other reproductive harm.

- Control dust, mist and fumes at the source where possible. Water should be used to control dust whenever feasible.
- Use good work practices and follow the recommendations of the manufacture, OSHA/NIOSH and other occupational trade associations.
- When hazards cannot be eliminated the operator and any bystanders should always wear a OSHA specified respirator for materials being handled.

**REFERENCES:** For details on safety rules and regulations in the United States, contact your local Occupational Safety and Health Administration (OSHA) office. Equipment operated in other countries must be operated and serviced in accordance and compliance with any and all safety requirements of that country. The publication of these safety precautions is done for your information. MBW does not by the publication of these precautions, imply or in any way represent that these are the sum of all dangers present near MBW equipment. If you are operating MBW equipment, it is your responsibility to insure that such operation is in full accordance with all applicable safety requirements and codes. All requirements of the United States Federal Occupational Safety and Health Administration Act must be met when operated in areas that are under the jurisdiction of that United States Department.

## Safety Decals

Carefully read and follow all safety decals. Keep them in good condition. If decals become damaged, replace as required. If repainting the unit, replace all decals. Decals are available from authorized MBW distributors. Order the decal set listed on the following page.

# WS500

21505

**WARNING**

OPERATION OF THIS EQUIPMENT MAY CREATE SPARKS THAT CAN START FIRES AROUND DRY VEGETATION. A SPARK ARRESTER MAY BE REQUIRED. THE OPERATOR SHOULD CONTACT LOCAL FIRE AGENCIES FOR LAWS OR REGULATIONS RELATING TO FIRE PREVENTION

19791

**U.S. PATENT 7,201,537  
6,988,851 ; 7,204,659**

19379

19379

↑ ↑ ↑  
**EXCITER  
LOCATION**

17768



21746

**WARNING**

Operating, servicing and maintaining this equipment can expose you to chemicals, including engine exhaust, phthalates and lead, which are known to the state of California to cause cancer and birth defects or other reproductive harm. Avoid breathing engine exhaust. Do not operate equipment in confined areas. For more information go to [www.P65Warnings.ca.gov](http://www.P65Warnings.ca.gov)

21820

21820

↑ ↑ ↑  
**EXCITER  
LOCATION**

17768

# MBW SCREEDEMON

17769

Safety Decals

# SPECIFICATIONS

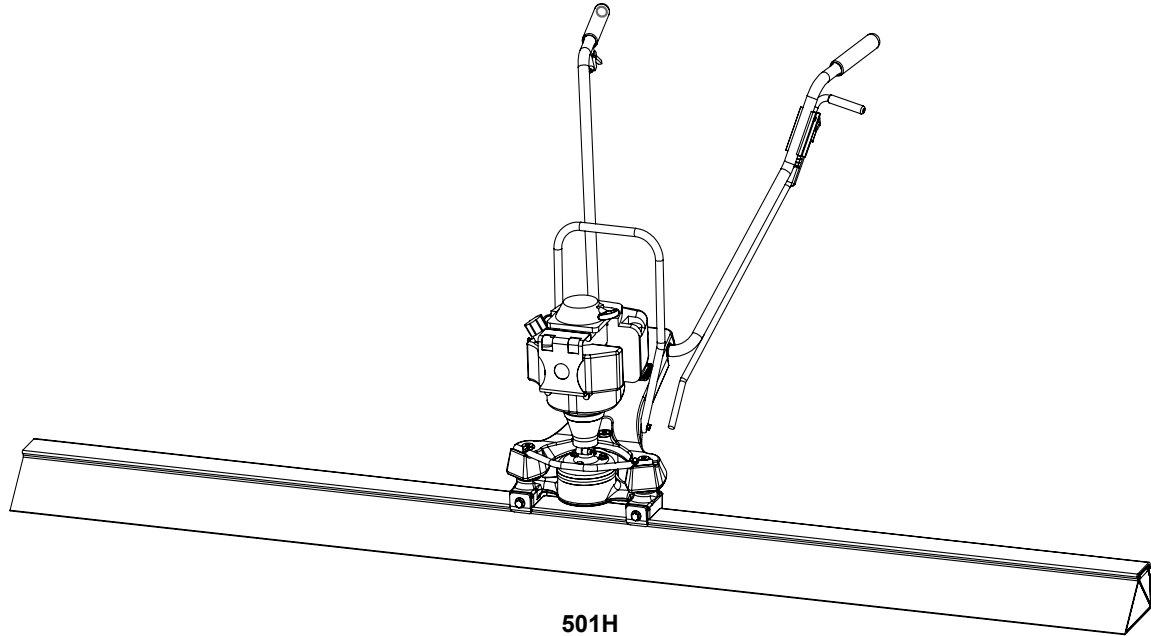

501H

	501H
Operating Weight	30 lbs (13.6 kg)
Engine Make	Honda
Engine Model	GX35NTT3
Displacement	(2.13 in <sup>3</sup> ) 35 cm <sup>3</sup>
Spark Plug	NGK CMR5H
Electrode Gap	0.024 -0.028in (0.6-0.7mm)
Engine Oil Type	SAE 10W30
Engine Oil Capacity	3.4 oz (0.1L)
Fuel Type	Regular Unleaded
Fuel Tank Capacity	0.17 gal (0.64 L)

## Blade Specifications

Width	Magnesium Blades		Aluminum Blades	
	Part #	Weight	Part #	Weight
4 ft (1.21 m)	17804	8.1 lb (3.7 kg)	-	-
6 ft (1.83 m)	17806	12.1 lb (5.5 kg)	23006	16.5 lb (7.5 kg)
8 ft (2.44 m)	17808	16.1 lb (7.3 kg)	23008	22.0 lb (10.0 kg)
10 ft (3.05 m)	17810	20.1 lb (9.1 kg)	23010	27.5 lb (12.5 kg)
12 ft (3.66 m)	17812	24.0 lb (10.9 kg)	23012	33.0 lb (15.0 kg)
14 ft (4.27 m)	17814	28.0 lb (12.7 kg)	-	-
16 ft (4.88 m)	17816	32.0 lb (14.5 kg)	-	-
18 ft (5.49 m)	17818	36.0 lb (16.3 kg)	-	-

Specifications subject to change without notice.

# OPERATION

## Introduction

MBW equipment is intended for use in very severe applications. They are powered by four cycle engines and are available in different sizes and a selection of engines.

This parts manual contains only standard parts. Variations of these parts as well as other special parts are not included. Contact your local MBW distributor for assistance in identifying parts not included in this manual.

## Before Starting & Operating

- **REMEMBER!** It is the owner's responsibility to communicate information on the safe use and proper operation of this unit to the operators.
- Review ALL of the Safety Precautions listed on page 1 of this manual.
- Familiarize yourself with the operation of the machine and confirm that all controls function properly.
- Know how to STOP the machine in case of an emergency.
- Make sure hands, feet, and clothing are at a safe distance from any moving parts.
- **OIL LEVEL** - Check the oil level in the engine. For more information see "Lubrication" under the respective engine's "Owners Manual" or the Maintenance section of this manual.
- **AIR CLEANER** - Check to ensure element is in good condition and properly installed.
- **FUEL SUPPLY** - The engines on MBW equipment require an automotive grade of clean, fresh, unleaded gasoline.
- **FUEL FILTER** - If clogged or damaged, replace.

## Attaching Blade

Refer to Figure 1.

1. Loosen the bolts that secure the clamps to the exciter assembly.
2. Lay the float blade on the floor with the decals facing upward.
3. Center the exciter between the "Exciter Location" decals on the float blade.
4. Tilt the exciter forward and hook the small leg of the clamping plates under the front lip of the float blade.

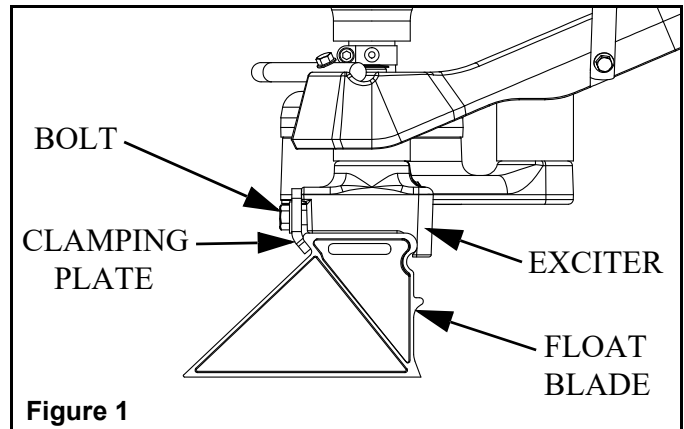

5. Set the exciter onto the blade so the rear part of the exciter casting lines up with the rear cavity of the float blade.
6. Tighten the clamping plate bolts.

## Starting Engine

1. Turn engine switch to "ON".
2. Press the primer bulb repeatedly until fuel can be seen in the clear plastic return tube.
3. Choke engine if necessary (you may not need to choke a warm engine).
4. Pull starter rope repeatedly until engine starts.
5. If choke was moved to the closed position to start, gradually move it to the open position as the engine warms up.
6. Allow engine to warm up for one or two minutes.

## Stopping Engine

1. Move throttle to idle position.
2. Let engine idle for one or two minutes.
3. Turn switch on engine to "STOP" position.
4. Turn off fuel valve.



## WARNING



**Always stop the engine before:**

**Adding fuel.**

**Leaving the equipment unattended for any amount of time.**

**Before making any repairs or adjustments to the machine.**

## Operation

Before placing the ScreeDemon in concrete make sure the clamps securing the exciter to the float blade are tight.



### CAUTION

Keep the blade clamps tight at all times. Operating the ScreeDemon with the clamps loose will damage the float blade.



### CAUTION

Never run the ScreeDemon above idle when the float blade is not in contact with concrete. This can damage the float blade.

The ScreeDemon can be used with or without forms. The following describes the use of the ScreeDemon without forms.

1. Use a hand float to make a 12-18" diameter wet pad (A) at the desired grade in the four corners of the area you wish to screed. The outer extents of the wet pads should not exceed the length of the float blade being used.

**NOTE:** Use a laser receiver, transit level, or grade stakes to help establish the correct grade.

2. Run the ScreeDemon between the wet pads to create two parallel strips (B) that define the grade for the remainder of the wet screeding. These strips should be 12-18" wide.

3. Place one end of the float blade on each of the parallel strips (B) and screed the concrete (C) in between the strips. Be sure the float blade follows the contour of the parallel strips.

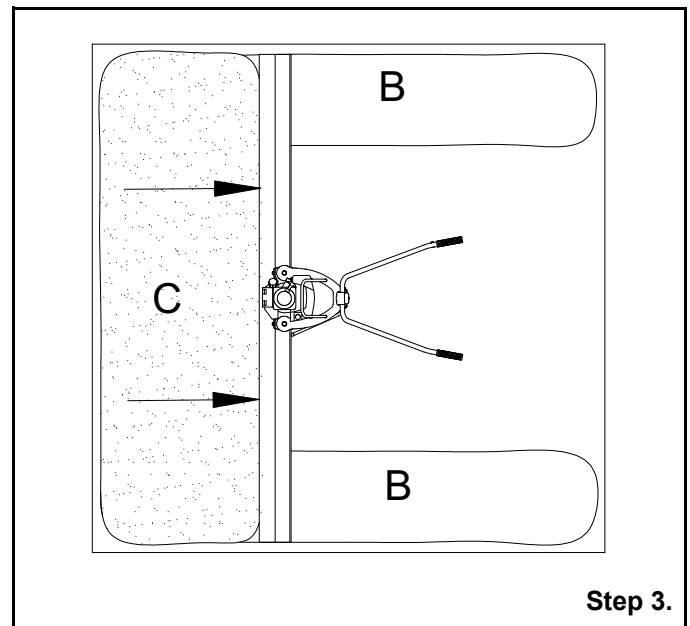
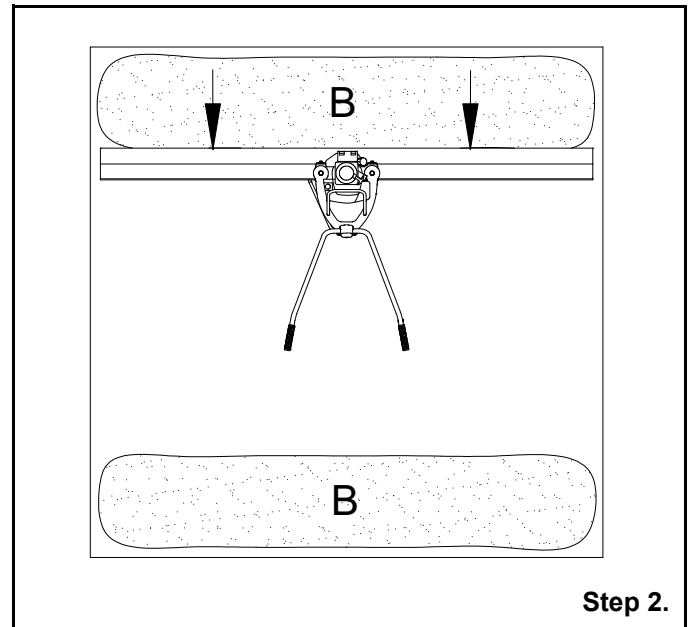
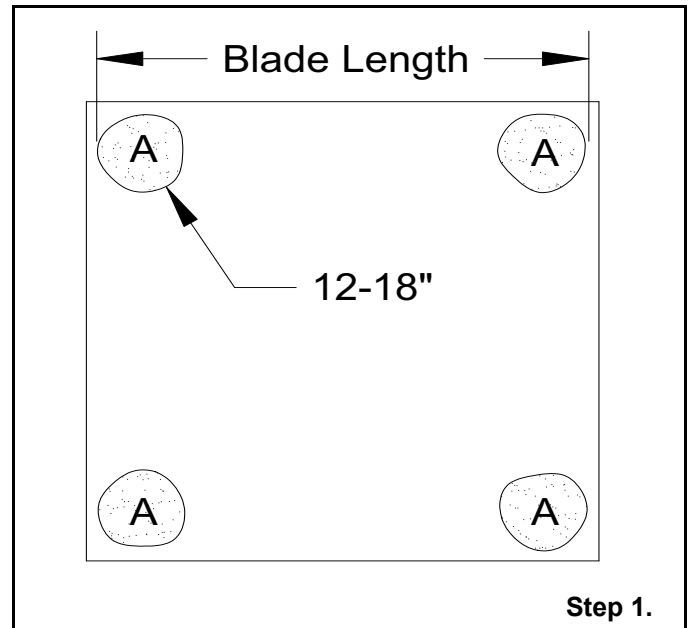

## Handle Adjustment

The operator can adjust the handle on the ScreeDemon to a comfortable position.

Refer to Figure 2.

1. Loosen the handle by turning the handle adjustment knob counter-clockwise.
2. Move the handle to the desired position.
3. Tighten the handle adjustment knob.

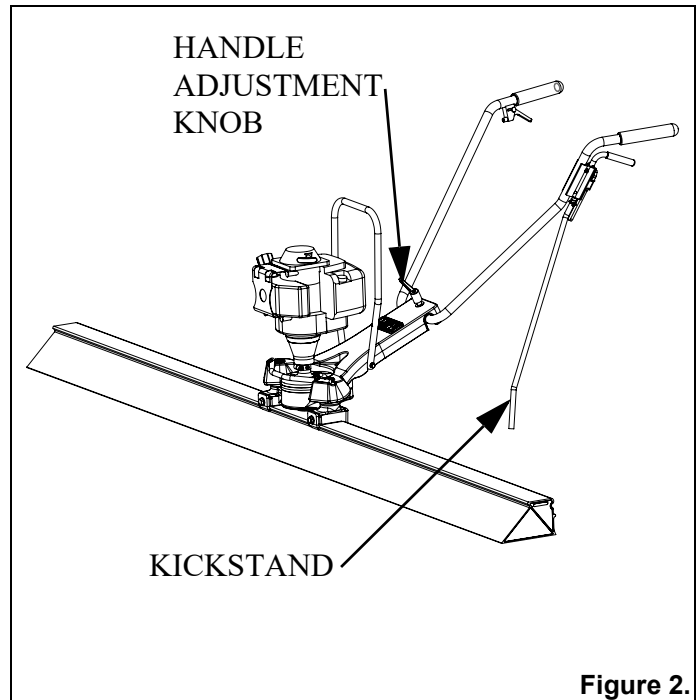

## Kickstand

The kickstand will support the ScreeDemon in an upright position when not in use.

Refer to Figure 2.

## Transporting

It is recommended to transport the ScreeDemon with the float bar removed. The float bar is more likely to be damaged if attached to the main unit during transport.

The handle can be collapsed for easier transport.

Refer to Figure 3.

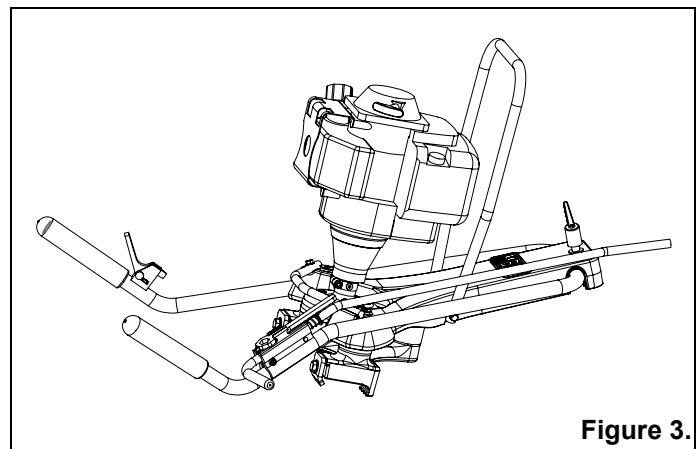

# MAINTENANCE



## WARNING



Always exercise the stopping procedure before servicing or lubricating the unit.

After servicing the unit, replace and fasten all guards, shields, and covers to their original positions before resuming operation.



## CAUTION



Always verify fluid levels and check for leaks after changing fluids.

Do not drain oil onto ground, into open streams, or down sewage drains.

## Maintenance Schedule

SYSTEM	MAINTENANCE	EACH USE	EVERY 20 HOURS	EVERY 100 HOURS	YEARLY
Engine	Refer to engine operator/owner manual	X			
Hardware	Check and tighten as needed <sup>1</sup>		X		X
Shockmounts	Check for cracks or tears		X		X

1. Check all hardware after the first 5 hours of use, then follow the maintenance schedule.
2. Service kit #20192

## Engine Maintenance

Refer to the engine owner's manual for maintenance intervals and procedures.

## Engine Speed

The idle speed of the engine should not exceed the following:

**Honda - 3500 rpm**

If the idle speed is greater the clutch may not disengage. Check engine owner's manual for procedure on setting idle speed.

## Cleaning

**Clean any concrete from the ScreeDemon immediately after each use. DO NOT allow concrete to harden on the screed.**

1. Use a hose to remove any excess concrete.
2. Remove any buildup with hard plastic bristle brush.

**NOTE: DO NOT use a wire brush, hammer, or pressure washer to remove concrete from the main unit or float blade.**

3. Remove the blade.
4. Start engine and run the exciter for about 10 seconds.
5. Shut down the engine.

# SERVICE

Assembly and disassembly should be performed by a service technician who has been factory trained on MBW equipment. The unit should be clean and free of debris. Cleaning unit before disassembly is recommended.

- Prior to assembly, wash all parts in a suitable cleaner or solvent.
- Check moving parts for wear and failure. Refer to the Replacement section in this manual for tolerance and replacement cycles.
- All shafts and housings should be oiled prior to pressing bearings. Also, ensure that the bearings are pressed square and are seated properly.
- All bearings should be replaced when rebuilding any exciter or gearbox.
- All gaskets and seals should be replaced after any disassembly.

## Torque Chart

SIZE	GRADE 2	GRADE 5	GRADE 8
1/4-20	49 in·lbs	76 in·lbs	9 ft·lbs
1/4-28	56 in·lbs	87 in·lbs	10 ft·lbs
5/16-18	8 ft·lbs	13 ft·lbs	18 ft·lbs
5/16-24	9 ft·lbs	14 ft·lbs	20 ft·lbs
3/8-16	15 ft·lbs	23 ft·lbs	33 ft·lbs
3/8-24	17 ft·lbs	26 ft·lbs	37 ft·lbs
7/16-14	24 ft·lbs	37 ft·lbs	52 ft·lbs
7/16-20	27 ft·lbs	41 ft·lbs	58 ft·lbs
1/2-13	37 ft·lbs	57 ft·lbs	80 ft·lbs
1/2-20	41 ft·lbs	64 ft·lbs	90 ft·lbs
9/16-12	53 ft·lbs	82 ft·lbs	115 ft·lbs
5/8-11	73 ft·lbs	112 ft·lbs	159 ft·lbs
M 6	3 ft·lbs	4 ft·lbs	7 ft·lbs
M 8	6 ft·lbs	10 ft·lbs	18 ft·lbs
M 10	10 ft·lbs	20 ft·lbs	30 ft·lbs

### CONVERSIONS

in·lbs x 0.083 = ft·lbs  
 ft·lbs x 12 = in·lbs  
 ft·lbs x 0.1383 = kg·m  
 ft·lbs x 1.3558 = N·m

## Engine Mounting Flange Removal

Refer to Engine and Engine Mount, page 16.

1. Disconnect the throttle cable (#21, page 12) from the engine (#9).
2. Loosen the 6mm socket head cap screw (#2) located at the base of the engine.
3. Pull the engine off the engine mounting flange (#4).

**NOTE: Silicon is used to seal the connection between the engine and the engine mounting flange. Rotating the engine will help break this seal.**

4. Remove the three 1/4-20 hex head cap screws and sealing washers (#29 & #24, page 12) from the engine mounting flange.
5. Remove the plug (#1) from the engine mounting flange.
6. Loosen the 1/4-20 socket head cap screw (#10, page 14) inside the exciter housing (#3, page 14) directly below the hole.
7. Stick a rod or screwdriver straight down through both holes.
8. Rotate the spline shaft (#6) until the exciter hits the rod and the spline shaft can no longer turn.
9. Use a pliers to grab the spline shaft below the spline. Rotate the shaft counter-clockwise to remove the engine mounting flange.

## Handle Removal

Refer to Main Assembly, page 12.

1. Disconnect the throttle cable (#21) from the engine.
2. Remove three plugs (#23) and 1/2-13 socket head cap screws (#34).
3. Remove the handle mount from the exciter.

## Exciter Disassembly

Refer to Exciter Assembly, page 14.

**The engine mounting flange must be removed before disassembling the exciter. See Engine Mounting Flange Removal, page 8.**

1. Unthread the three shockmounts (#5) from the exciter housing (#3). Unthread the center shockmount (#5) from the exciter (#9).
2. Loosen the three 1/4-20 socket head cap screws (#11) securing the exciter cover (#6) to the exciter housing. Back the socket head cap screws out about 1/4".

3. Gently tap on the socket head cap screws with a rubber mallet to push the exciter cover out of the exciter housing.
4. Remove the 1/4-20 socket head cap screws after the exciter cover is free from the exciter housing.
5. Remove the two bearings (#4) from the exciter housing, and exciter cover.

5. Position the engine mounting flange (#4) so the plug hole lines up with the 1/4-20 socket head cap screw (#10, page 14) on the exciter.

## Exciter Assembly

Refer to Exciter Assembly, page 14.

1. Press a bearing (#4) into the exciter housing (#3) and exciter cover (#6).
2. Turn the exciter housing up-side-down and place the the threaded end of the exciter shaft/weight assembly into the bearing in the housing.
3. Apply a light coat of grease to the top step of the exciter cover (#6). Place a new o-ring (#1) onto the greased step.
4. Apply medium strength thread locker to the threaded holes in the cover.
5. Line up the mounting holes between the exciter housing and exciter cover and assemble the exciter cover to the exciter housing. Take care not to cut the o-ring. Secure the cover with three 1/4-20 socket head cap screws (#11).
6. Thread the four shockmounts (#5) into the exciter housing and exciter.
7. Apply medium strength thread locker to the 1/4-20 socket head cap screw (#10) and thread it into the exciter housing.

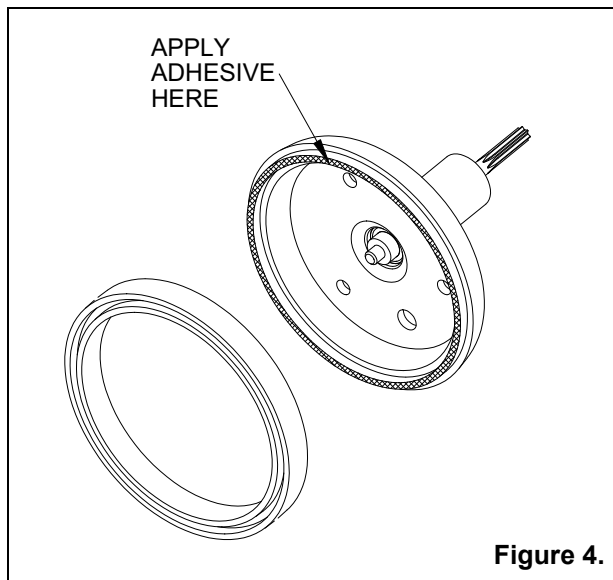

Figure 4.

**NOTE: Do not use any sealant or adhesive between the bottom of the rubber seal and the top of the exciter.**

6. Set the engine mounting flange in place while turning the spline shaft (#6) clockwise to thread the shaft into the center shockmount (#5, page 14) on top of the exciter housing (#3, page 14). This only needs to be hand tight.
7. Secure the engine mounting flange with three sealing washers (#24, page 12) and three 1/4-20 hex head cap screws (#29, page 12).
8. Replace the plug (#1).
9. Place a small bead of 100% silicon sealant around the engine mounting flange about 1/2" from the top. Also fill the slot on the engine housing with silicone.
10. Orient the engine (#9) so the fuel tank faces away from the operating position and slide the engine over the engine mounting flange.

**NOTE: Make sure the engine slides all the way down to the step on the engine mounting flange. The engine may have to be lifted and rotated to engage the splines.**

11. Tighten the 6mm socket head cap screw (#2) at the base of the engine.)
12. Reattach the throttle cable (#21, page 12 to the engine.

## Engine Mounting Flange & Engine Assembly

Refer to Engine and Engine Mount, page 16

1. Inspect the rubber seal (#8). Remove if there are any tears or if it is worn. If the rubber seal is in good condition, skip to step #5.
2. Clean the surfaces of the engine mounting flange (#4) where the rubber seal was glued.
3. Apply a small bead of Loctite 426 adhesive (MBW #17885) to the lip on the engine mounting flange. See Figure 4.
4. Place a new rubber seal onto the engine mounting flange and hold it in place for 10 seconds to allow the adhesive to set up.

## Parts Replacement Cycles and Tolerances

<b>Bearings</b>	Replace anytime a bearing is rough, binding, discolored or removed from housing or shaft.
<b>Engine Components</b>	Refer to your engine manufacturer's Owner's Manual.

<b>Hardware</b>	Replace any worn or damaged hardware as needed. Replacement hardware should be grade 5 and zinc plated unless otherwise specified.
<b>Safety Decals</b>	Replace if they become damaged or illegible.
<b>Seals, O-rings, &amp; Gaskets</b>	Replace if a leak is detected and at every overhaul or teardown.

# REPLACEMENT PARTS

---

The warranty is stated in this book on page 18. Failure to return the Warranty Registration Card renders the warranty null and void.

MBW has established a network of reputable distributors/dealers with trained mechanics and full facilities for maintenance and rebuilding, and to carry an adequate parts stock in all areas of the country. Their sales engineers are available for professional consultation. If you cannot locate an MBW distributor in your area, contact MBW or one of our Sales Branches listed below.

When ordering replacement parts, be sure to have the following information available:

- Model and Serial Number of machine when ordering MBW parts
- Model and Serial Number of engine when ordering engine parts
- Part Number, Description, and Quantity
- Company Name, Address, Zip Code, and Purchase Order Number
- Preferred method of shipping

**REMEMBER - You own the best! If repairs are needed, use only MBW parts purchased from authorized MBW distributors.**

SERIAL  
NUMBER  
DECAL

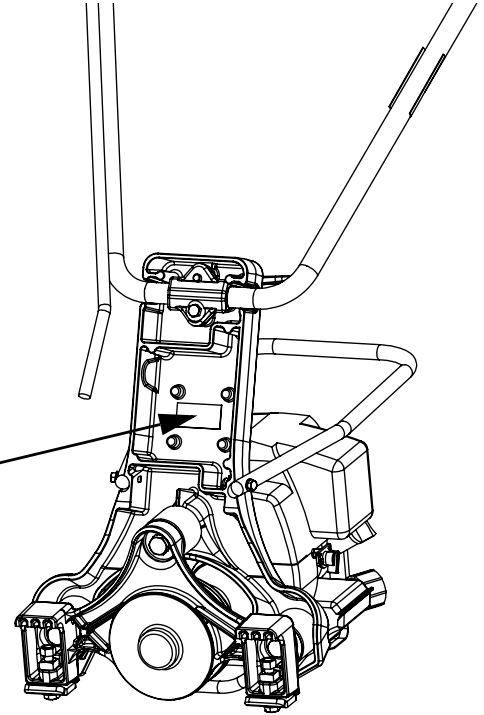

The unit's serial number can be found in the following locations:

- The model/serial number decal is located on the underside of the a-frame.

Write Model Number here

Write Serial Number here

---

## Contact Information

### MBW, Inc.

250 Hartford Rd • PO Box 440  
Slinger, WI 53086-0440  
Phone: (262) 644-5234  
Fax: (262) 644-5169  
Email: [mbw@mbw.com](mailto:mbw@mbw.com)  
Website: [www.mbw.com](http://www.mbw.com)

### MBW Europe Ltd.

Units 2 & 3 Cochrane Street  
Bolton BL3 6BN  
England, UK  
Phone: +44 (0) 01204 387784  
Fax: +44 (0) 01204 387797  
Email: [saleseurope@mbw.com](mailto:saleseurope@mbw.com)  
Website: [mbw-europe.com](http://mbw-europe.com)

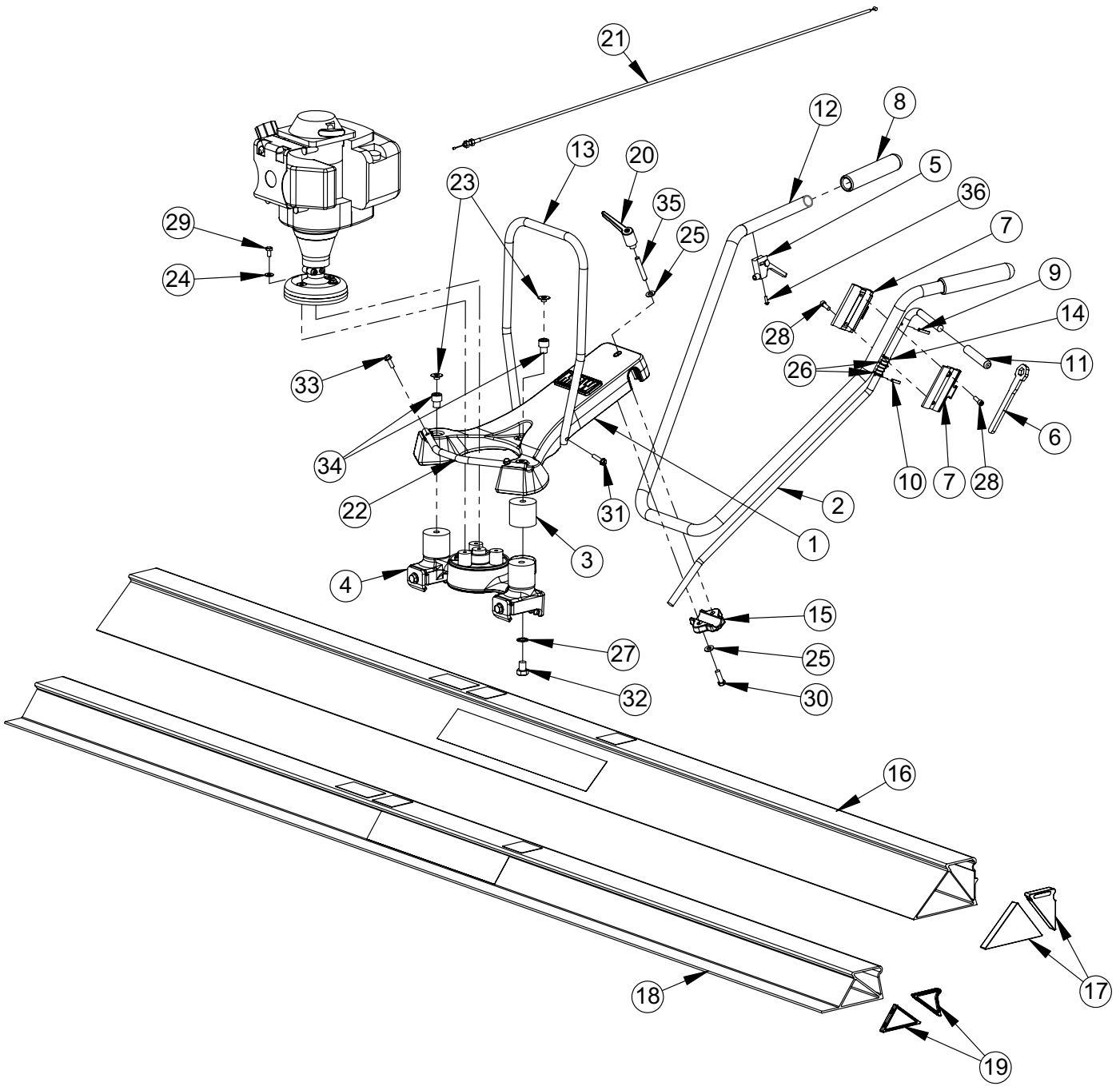

**Main Assembly**

ITEM	PART NO.	DESCRIPTION	QTY
1.	23139	A FRAME	1
2.	23141	KICKSTAND	1
3.	17170	SHOCKMOUNT 2.00" OD x 1-3/4" LONG	1
4.	23049	EXCITER ASSEMBLY	1
5.	22937	TRIGGER, THROTTLE, 501H	1
6.	23148	WRENCH	1
7.	23147	KICKSTAND MOUNT	2
8.	18472	GRIP, HANDLE	2
9.	F0308SP	SPIROL PIN, 3/16 x 1	1
10.	F0306SP	SPIROL PIN, 3/16 x 3/4	1
11.	23144	GRIP, KICKSTAND	1
12.	23151	OPERATING HANDLE	1
13.	23157	LIFTING HANDLE	1
14.	23143	KICKSTAND SPRING	1
15.	23059	HANDLE CLAMP	1
16.	17804	4' FLOAT, MAGNESIUM	1
	17806	6' FLOAT, MAGNESIUM	1
	17808	8' FLOAT, MAGNESIUM	1
	17810	10' FLOAT, MAGNESIUM	1
	17812	12' FLOAT, MAGNESIUM	1
	17814	14' FLOAT, MAGNESIUM	1
	17816	16' FLOAT, MAGNESIUM	1
	17818*	18' FLOAT, MAGNESIUM	1
17.	17831	END CAPS, FLOAT (CONTAINS ALL 4 CAPS NEEDED FOR MAGNESIUM FLOAT)	1
18.	23106	6' FLOAT, ALUMINUM	1
	23108	8' FLOAT, ALUMINUM	1
	23110	10' FLOAT, ALUMINUM	1
	23112	12' FLOAT, ALUMINUM	1
19.	23084	END CAPS, FLOAT (CONTAINS ALL 4 CAPS NEEDED FOR ALUMINUM FLOAT)	1
20.	21181	HANDLE, ADJUSTMENT	1
21.	22938	CABLE, THROTTLE, 501H	1
22.	23057	FRONT HANDLE	1
23.	23060	PLUG, 1/2	3
24.	17639	WASHER, SEALING	3
25.	F05PW	WASHER, 5/16" SAE	2
26.	23142	WASHER, .526 ID x .812 OD	2
27.	M12ETLW	LOCK WASHER, M12	1
28.	F042006SCS	SOCKET HEAD CAP SCREW, 1/4"-20 x 3/4"	2
29.	F042004HCS	HEX HEAD CAP SCREW, 1/4"-20 x 1/2"	3
30.	F051808HCS	HEX HEAD CAP SCREW, 5/16"-18 x 1"	1
31.	23153	FLANGE SCREW, 1/4"-20 x 1"	2
32.	F081305HCS	HEX HEAD CAP SCREW, 1/2"-13 x 5/8"	1
33.	F042006FWS	FLANGE SCREW, 1/4"-20 x 3/4"	2
34.	F081304SCS	SOCKET HEAD CAP SCREW, 1/2"-13 x 1/2"	3
35.	23058	STUD, 5/16"-18 x 2"	1
36.	23136	THREAD FORMING SCREW, #8-32 x 1/2"	1

\*Dual power heads required for 18' blades and above.

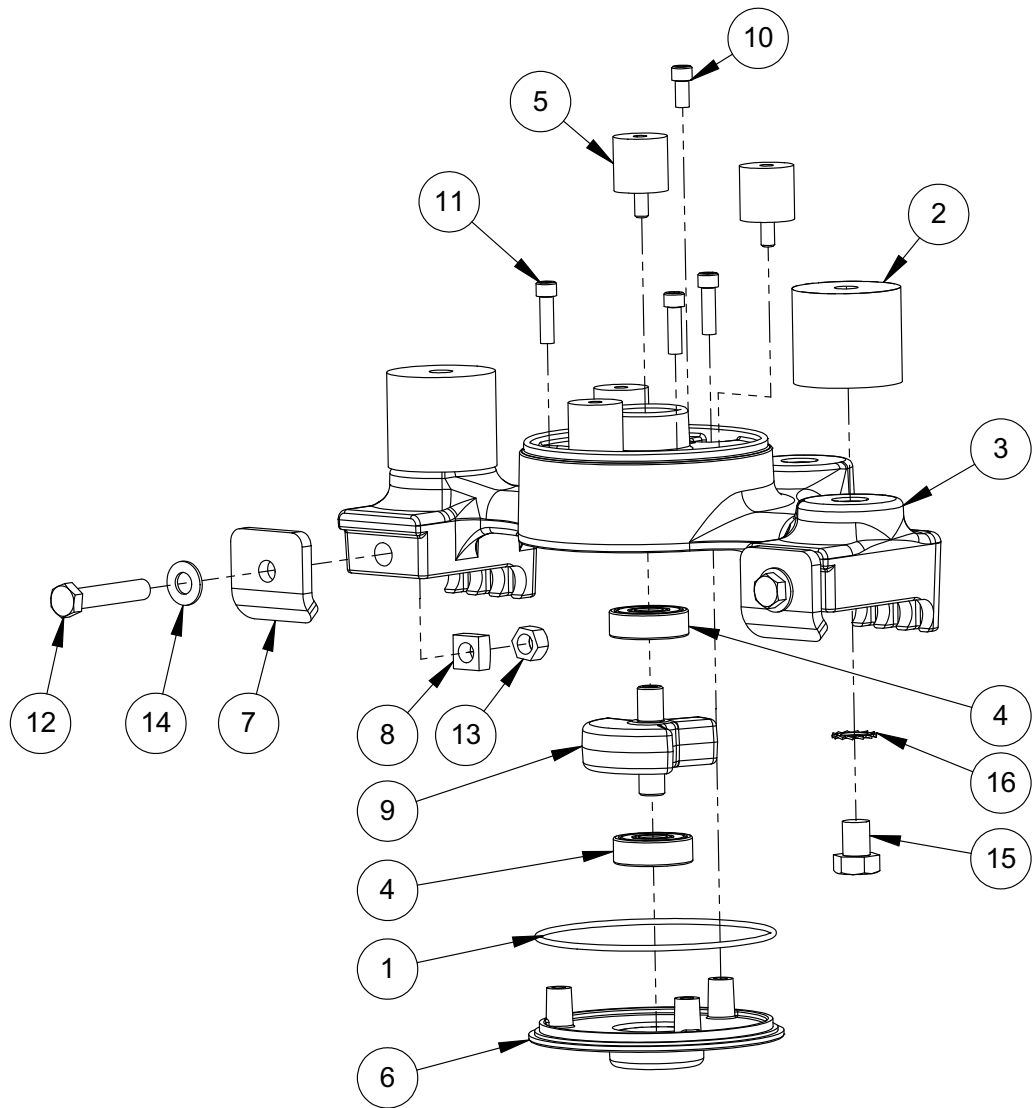

# Exciter Assembly



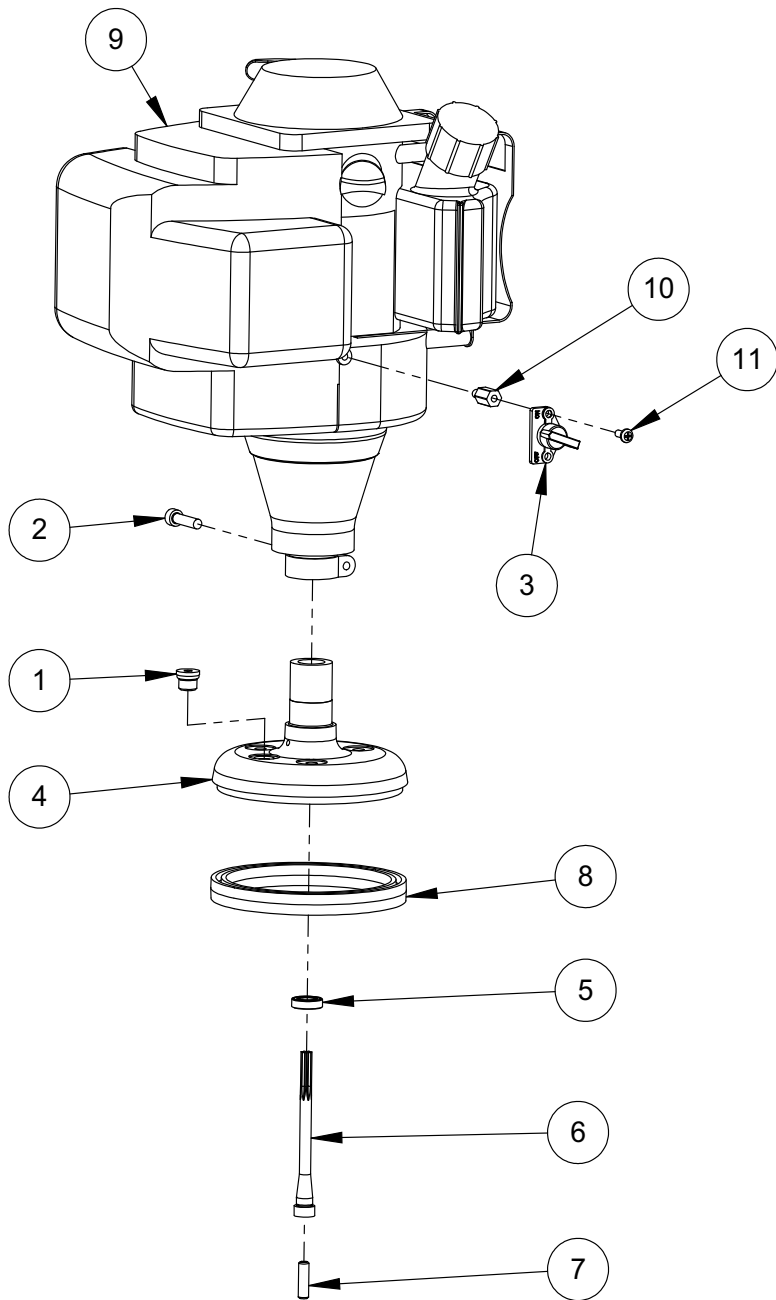

## Engine and Engine Mount



# WARRANTY

1. IN GENERAL - The warranties described in this document are provided by M-B-W, INC. and MBW EUROPE, LTD. ("MBW") to define what is, what is not, and for how long machines and parts are covered against material defects and/or defective workmanship. To obtain warranty service, the purchaser must, within the Warranty Period (defined in Paragraph 3): (i) report the product defect to an authorized repair center, (ii) make a written request for repair, (iii) provide proof of purchase to the authorized repair center, and (iv) deliver the equipment to the authorized repair center. A list of authorized repair centers is available on the MBW website (mbw.com) or by contacting MBW at 800-678-5237.

2. COVERED - MBW's obligation under this limited warranty is limited to the cost of the parts and the labor to repair any defect in material and/or workmanship at an authorized MBW repair center. Transportation charges are not covered by this limited warranty.

3. WARRANTY PERIODS - The Warranty Period begins on, as applicable: (i) the product purchase date by an end user or (ii) the first day the product is put into rental or two years after invoice date from MBW to Dealer, whichever starts the warranty period first. To insure that your warranty is in place, fill out the warranty card and mail it in or register your product online at [www.mbw.com/service-support/warranty-registration](http://www.mbw.com/service-support/warranty-registration). The warranty is nontransferable.

The Warranty Period ends after:

- A. New Ground compaction equipment - 2 years.
  - B. New Concrete finishing equipment - 1 year.
  - C. New Utility equipment - 1 year.
  - D. Demonstration equipment - 6 months.
  - E. Wear parts: lubricants, filters, belts and shock mounts - 30 days.
4. NOT COVERED- This warranty does not include, and MBW specifically excluded from any warranty:
- A. Used equipment - all used equipment is not warranted and is sold 'as is' 'where is' with all defects.
  - B. Replacement electrical parts, including but not limited to: electric motors, circuit boards, switches, are not warranted or returnable.
  - C. OEM: engines, batteries, and chargers. Those warranties are covered by the manufacturer.
  - D. Consumable parts: trowel and screed blades.
  - E. Equipment that has been: altered, abused, neglected, not maintained, or modified to run outside its specifications. Any modification to the machine or its parts makes this warranty null and void.
  - F. Other: damage to a product from normal wear, air freight, overtime, pickup and delivery, temporary replacement rentals, freight damage, or other similar incidents.
  - G. Product used in a fashion it was not designed for.
  - H. Parts and labor not performed by authorized dealers.

It is at MBW's discretion if warranty applies and has the right to adjust labor rates on a claim by claim basis.

**5. OTHER - IT IS EXPRESSLY AGREED THAT THIS SHALL BE THE SOLE AND EXCLUSIVE REMEDY UNDER THIS WARRANTY. UNDER NO CIRCUMSTANCES SHALL MBW BE LIABLE FOR ANY COSTS, LOSS, EXPENSE, DAMAGE, SPECIAL DAMAGES, DIRECT DAMAGES, INCIDENTAL DAMAGES, EXEMPLARY, CONSEQUENTIAL, OR PUNITIVE DAMAGES ARISING DIRECTLY OR INDIRECTLY FROM THE USE OF MBW PRODUCT OR DAMAGES FOR LOSS OF USE, LOSS OF ANTICIPATED PROFITS, INCOME, OR ECONOMIC LOSSES OF ANY KIND. MBW'S LIABILITY TO BUYER UNDER THESE WARRANTIES FOR THE PRODUCT IS LIMITED AS SET FORTH HEREIN, WHETHER BASED UPON WARRANTY, CONTRACT, NEGLIGENCE, TORT, STRICT LIABILITY OR ANY OTHER THEORY OF LIABILITY, INCLUDING BUT NOT LIMITED TO FRAUD, MISREPRESENTATION, BREACH OF CONTRACT, PERSONAL INJURY, PRODUCTS LIABILITY OR ANY OTHER THEORY.**

MBW'S LIABILITY UNDER ANY WARRANTY HEREUNDER, WHETHER EXPRESS OR IMPLIED, SHALL NOT EXCEED THE COST OF REPAIR OR REPLACEMENT OF DEFECTIVE PARTS OF THE PRODUCT OR THE PRODUCT. BUYER MAY NOT BRING ANY ACTION UNDER THESE WARRANTIES MORE THAN ONE YEAR AFTER THE CAUSE OF ACTION HAS ACCRUED.

**THE FORGOING WARRANTY IS EXPRESSED IN LIEU OF ALL OTHER WARRANTIES, EXPRESSED OR IMPLIED, INCLUDING THE WARRANTIES OF MERCHANTABILITY, FITNESS FOR USE, AND FITNESS FOR A PARTICULAR PURPOSE, AND ALL OTHER OBLIGATIONS OR LIABILITY ON MBW'S PART. MBW SPECIFICALLY DISCLAIMS AND EXCLUDES ANY AND ALL WARRANTIES OF MERCHANTABILITY AND FITNESS FOR A PARTICULAR PURPOSE.**

**MBW NEITHER ASSUMES NOR AUTHORIZES ANY OTHER PERSON TO ASSUME ON BEHALF OF MBW ANY OTHER LIABILITY OR WARRANTY IN CONNECTION WITH THE SALE OR SERVICE OF ANY MBW PRODUCT.**

Some states do not allow limitations on how long an implied warranty lasts, so the above limitation may not apply to you. This warranty gives you specific legal rights, and you may also have other rights which vary from state to state.